



Government Institutes

# ERGONOMICS MADE EASY

Second Edition

A Checklist Approach

Deborah S. Kearney

# *Ergonomics Made Easy*

---



SECOND EDITION

## *A Checklist Approach*

*Deborah S. Kearney*

Government Institutes  
An imprint of  
The Scarecrow Press, Inc.  
Lanham, Maryland • Toronto • Plymouth, UK  
2008

Published in the United States of America  
by Government Institutes, an imprint of The Scarecrow Press, Inc.  
A wholly owned subsidiary of  
The Rowman & Littlefield Publishing Group, Inc.  
4501 Forbes Boulevard, Suite 200  
Lanham, Maryland 20706  
<http://www.govinstpress.com/>

Estover Road  
Plymouth PL6 7PY  
United Kingdom

Copyright © 2008 by Government Institutes

*All rights reserved.* No part of this publication may be reproduced, stored in a retrieval system, or transmitted in any form or by any means, electronic, mechanical, photocopying, recording, or otherwise, without the prior permission of the publisher.

The reader should not rely on this publication to address specific questions that apply to a particular set of facts. The author and the publisher make no representation or warranty, express or implied, as to the completeness, correctness, or utility of the information in this publication. In addition, the author and the publisher assume no liability of any kind whatsoever resulting from the use of or reliance upon the contents of this book.

British Library Cataloguing in Publication Information Available

Library of Congress Cataloging-in-Publication Data

Kearney, Deborah S.

Ergonomics made easy : a checklist approach / Deborah J. Kearney. — 2nd ed.

p. cm.

Includes bibliographical references and index.

ISBN-13: 978-0-86587-194-6 (paper : alk. paper)

ISBN-10: 0-86587-194-9 (paper : alk. paper)

eISBN-13: 978-1-60590-272-2

eISBN-10: 1-60590-272-1

1. Human engineering. I. Title.

TA166.K39 2008

620.8'2—dc22

2008018619

©<sup>TM</sup> The paper used in this publication meets the minimum requirements of American National Standard for Information Sciences—Permanence of Paper for Printed Library Materials, ANSI/NISO Z39.48-1992.  
Manufactured in the United States of America.

# Contents

---



List of Figures . . . . .	xix
Preface . . . . .	xxi
<b>Introduction: Ergonomics and Safety Management . . . . .</b>	<b>1</b>
The Occupational Safety and Health Act and Ergonomics . . . . .	1
Safety Professionals: Sources of Risk Reduction . . . . .	2
Competency-Based Job Descriptions . . . . .	2
Job Safety Analysis (JSA) . . . . .	2
Understanding of the Human Body . . . . .	3
Integrative Design . . . . .	3
Ergonomics and Design . . . . .	4
Designing for Aging, Disability, Disease, and Injury . . . . .	5
Designing for Aging . . . . .	5
Designing for Disability . . . . .	6
Designing for Disease . . . . .	7
Designing for Injury . . . . .	7
Introduction to the Human Body . . . . .	7
The Brain and Central Nervous System . . . . .	7
Nerves . . . . .	9
The Musculoskeletal System . . . . .	9
Front Skeleton . . . . .	9
Back Skeleton . . . . .	12
Bones . . . . .	12
Inside the Spine . . . . .	13
The Neck . . . . .	13
Vertebrae and Disks . . . . .	13
Hip, Thigh, and Knee . . . . .	13
The Foot . . . . .	14
Soft Tissue . . . . .	14
Muscles . . . . .	15
Tendons . . . . .	15

Ligaments . . . . .	16
Cartilage . . . . .	16
Joints . . . . .	16
The Shoulder . . . . .	16
Injuries to the Body . . . . .	17
Nerve Root Problems. . . . .	17
Musculoskeletal Ailments . . . . .	17
Trigger Points. . . . .	17
Degenerative Joint Disease. . . . .	17
The Shoulder in Trouble . . . . .	18
Knee Problems. . . . .	18
Unhealthy Spines . . . . .	18
How Disks Wear Out. . . . .	18
Sciatica. . . . .	19
Muscle Spasm . . . . .	19
Foot and Ankle Problems. . . . .	19
Hand Injuries. . . . .	19
Strains and Sprains. . . . .	20
Tendonitis . . . . .	20
The Senses and Ergonomics . . . . .	20
Vision . . . . .	21
Hearing . . . . .	21
Touch. . . . .	22
A Factor Analysis Approach to Safety Management and Ergonomics . . . . .	23
<b>Section 1: Accessibility. . . . .</b>	<b>25</b>
1.1 Ergonomic Design Benefits. . . . .	26
1.2 Consequences of Not Using Ergonomic Design . . . . .	26
1.3 Importance of Accessibility . . . . .	26
1.4 Accessibility Guidelines . . . . .	27
<b>Section 2: Adaptability. . . . .</b>	<b>29</b>
2.1 Ergonomic Design Benefits. . . . .	30
2.2 Consequences of Not Using Ergonomic Design . . . . .	30
2.3 Importance of Adaptability . . . . .	30
2.4 Ergonomic Adaptability . . . . .	30
2.5 Design Recommendations . . . . .	31
<b>Section 3: Air Quality. . . . .</b>	<b>32</b>
3.1 Ergonomic Design Benefits. . . . .	33
3.2 Consequences of Not Using Ergonomic Design . . . . .	33
3.3 Air Quality and Ergonomic Design . . . . .	33
3.4 Ergonomics and Defining Fresh Air Architecture. . . . .	34
3.5 Eight Major Categories of Innovation Deemed Critical to the Emerging Definition of Fresh Air Architecture . . . . .	34
3.6 Factors Affecting Indoor Air Quality . . . . .	34
3.6.1 Indoor Contaminants . . . . .	34

---

3.7	More Healthful Enclosure Design for the Workplace . . . . .	36
3.7.1	Design Provisions . . . . .	36
3.7.2	Ventilation . . . . .	36
<b>Section 4: Benchmarking</b>		<b>38</b>
4.1	Ergonomic Design Benefits. . . . .	39
4.2	Consequences of Not Using Ergonomic Design . . . . .	39
4.3	Importance of Benchmarking. . . . .	39
4.3.1	Possible Areas for Benchmarking . . . . .	39
4.3.2	Areas of Interaction . . . . .	40
4.3.3	Structure of the Safety Department . . . . .	40
4.4	Suggested Tasks for Implementation of a Benchmarking Study . . . . .	40
4.4.1	Implementation. . . . .	40
4.5	The Measurement Process . . . . .	40
4.5.1	General Measurement Processes . . . . .	41
4.6	ISO 9000 . . . . .	42
4.6.1	ISO Standard Is a Twofold Opportunity . . . . .	42
4.7	Areas of Interest in Ergonomic Planning . . . . .	42
4.8	Quality Measures. . . . .	42
4.9	Financial Measures . . . . .	42
4.10	Timeliness Measures . . . . .	43
4.11	Productivity/Efficiency Measures . . . . .	43
4.12	Locations and Their Components . . . . .	43
4.13	Goals for a Safety Project. . . . .	44
4.14	Workforce Statistics . . . . .	45
4.15	More Healthful Interior Design for the Workplace. . . . .	45
<b>Section 5: Comfort</b>		<b>46</b>
5.1	Ergonomic Design Benefits. . . . .	47
5.2	Consequences of Not Using Ergonomic Design . . . . .	47
5.2.1	Increased Workers' Compensation Claims . . . . .	47
5.2.2	Results of Muscles Working at Maximum Capacity . . . . .	47
5.3	Use of Telephones . . . . .	48
5.3.1	Suggested Telephone Techniques and Purchases . . . . .	48
5.3.2	Caution. . . . .	48
5.4	Proper Chair Adjustments with Footrest . . . . .	48
5.5	Seating . . . . .	48
5.6	Footrests . . . . .	49
5.7	Seating and Comfort . . . . .	49
5.7.1	Postural Supports . . . . .	49
5.7.2	Maintenance of Balance . . . . .	49
5.7.3	What Chairs Must Support. . . . .	49
5.7.4	Body Position . . . . .	49
5.7.5	Seat Pan . . . . .	51
5.7.6	Backrests. . . . .	51
5.7.7	Footrests. . . . .	51
5.8	Integration of Seating with Workstation Task Design. . . . .	51

<b>Section 6: Communication</b> . . . . .	<b>53</b>
6.1 Ergonomic Design Benefits. . . . .	54
6.2 Consequences of Not Using Ergonomic Design . . . . .	54
6.3 Goals of Ergonomic Communication. . . . .	54
6.4 Operational Considerations of Communication. . . . .	54
6.5 Supports and Service Amenities Critical to Communication. . . . .	55
<b>Section 7: Cost Effectiveness</b> . . . . .	<b>58</b>
7.1 Ergonomic Design Benefits. . . . .	59
7.2 Consequences of Not Using Ergonomic Design . . . . .	59
7.3 Cost-Related Decisions That Must Be Made . . . . .	59
7.4 Formula of Value . . . . .	59
7.5 Goal. . . . .	60
7.6 Objectives . . . . .	60
7.7 Developing an Estimate . . . . .	60
7.7.1 Areas of Financial Management . . . . .	60
7.7.2 Information Requirements . . . . .	60
7.8 Cost of Operations as It Relates to Ergonomics . . . . .	63
7.8.1 Project Cost . . . . .	63
7.9 Factors That Relate Safety Management to Ergonomics . . . . .	63
7.9.1 Economic and Client Priority Considerations of Ergonomics . . . . .	64
<b>Section 8: Density</b> 65	
8.1 Ergonomic Design Benefits. . . . .	66
8.2 Consequences of Not Using Ergonomic Design . . . . .	66
8.3 Design Considerations . . . . .	66
8.3.1 Density Considerations . . . . .	66
8.4 Improvement of Density and Spatial Quality in the Individual Workplace . . . . .	67
8.4.1 Improving Workspace Design . . . . .	67
8.4.2 Connectivity in the Individual Workstation. . . . .	67
8.5 Ergonomics and Density . . . . .	69
8.5.1 Usable Area. . . . .	69
8.5.2 Assignable Area . . . . .	69
8.5.3 Space Distribution System. . . . .	70
8.5.4 Service Hubs and Shared Equipment. . . . .	70
8.5.5 Conference Hubs . . . . .	70
<b>Section 9: Design</b> 72	
9.1 Ergonomic Design Benefits. . . . .	73
9.2 Consequences of Not Using Ergonomic Design . . . . .	74
9.3 Ergonomic Design and Amenity Services . . . . .	74
9.3.1 Employee Services. . . . .	74
9.3.2 Facility Operations . . . . .	74
9.3.3 Factors to Be Evaluated. . . . .	74
9.3.4 What Employers Want to Know . . . . .	75

9.3.5 Satisfying Criteria While Meeting Corporate Standards, . . . . .	75
Laws, and Guidelines	
9.3.6 What Both Employees and Employers Want to Know. . . . .	76
9.3.7 Design Recommendations. . . . .	76
9.3.8 Quality Check Considerations . . . . .	76
<b>Section 10: Division of Space . . . . .</b>	<b>77</b>
10.1 Ergonomic Design Benefits. . . . .	78
10.2 Consequences of Not Using Ergonomic Design . . . . .	78
10.3 Workplace Use. . . . .	78
10.3.1 Working at Many Locations . . . . .	79
10.3.2 Changing Office Approaches . . . . .	80
10.4 Ergonomics of the Shared Office . . . . .	80
10.4.1 Non-Territorial Spaces . . . . .	80
10.4.2 Free Address . . . . .	81
10.4.3 Home Base/Cave and Commons . . . . .	81
10.4.4 Telecommuting . . . . .	81
10.4.5 Media Space . . . . .	81
10.4.6 Operational Issues on Non-Traditional Spaces . . . . .	81
10.5 Ergonomic Adaptability at Work . . . . .	82
10.5.1 Changing Work Styles. . . . .	83
10.6 Adaptability and Productivity . . . . .	83
<b>Section 11: Energy 84</b>	
11.1 Ergonomic Design Benefits. . . . .	85
11.2 Consequences of Not Using Ergonomic Design . . . . .	85
11.3 Energy/Resource Management. . . . .	85
11.4 Legislative Milestones . . . . .	86
11.4.1 Past Accomplishments. . . . .	86
11.5 Over-Utilization . . . . .	86
11.6 Subtitle E: State and Local Assistance . . . . .	87
11.7 Subtitle F: Federal Agency Energy Management. . . . .	87
<b>Section 12: Engineering Controls . . . . .</b>	<b>88</b>
12.1 Ergonomic Design Benefits. . . . .	89
12.2 Consequences of Not Using Ergonomic Design . . . . .	90
12.3 Risk Factors Reduced by the Use of Engineering Controls Guidelines . . . . .	90
12.3.1 Excessive Force . . . . .	90
12.3.2 Static or Dynamic Awkward Postures . . . . .	91
12.3.3 Repetitive-Motion Tasks . . . . .	91
12.3.4 Duration . . . . .	91
12.3.5 Vibration Stress. . . . .	91
12.3.6 Temperature Extremes . . . . .	92
12.3.7 Vibration Combined with Temperature Extremes . . . . .	92
12.4 Final Note . . . . .	92

<b>Section 13: Equipment</b> .....	<b>93</b>
13.1 Ergonomic Design Benefits. ....	94
13.2 Consequences of Not Using Ergonomic Design .....	94
13.3 Controls. ....	94
13.4 Coding Controls .....	95
13.5 Visual Displays on Equipment Criteria. ....	96
13.5.1 Quantitative Scales .....	96
13.5.2 Status Indicators .....	97
13.5.3 Signals and Warning Lights. ....	97
13.5.4 Representational Displays. ....	97
13.5.5 Alphanumeric Displays. ....	97
13.5.6 Symbolic Displays. ....	97
13.6 Technology Systems. ....	98
13.7 ANSI B11 Technical Report. ....	98
<b>Section 14: Finishes</b> .....	<b>99</b>
14.1 Ergonomic Design Benefits. ....	100
14.2 Consequences of Not Using Ergonomic Design .....	100
14.3 Floor Systems. ....	100
14.4 Finishes .....	100
14.5 Floors. ....	101
14.6 Walls .....	101
14.7 Ceilings .....	101
14.8 Color Choices .....	101
14.9 Color's Impact .....	101
14.10 Positive Values .....	102
14.11 Practical Approach. ....	103
<b>Section 15: Furnishings</b> .....	<b>105</b>
15.1 Ergonomic Design Benefits. ....	106
15.2 Consequences of Not Using Ergonomic Design .....	106
15.3 Evaluating and Selecting Ergonomic Furniture and Equipment . . .	106
15.3.1 Workstation Design. ....	107
<b>Section 16: Housekeeping</b> .....	<b>108</b>
16.1 Ergonomic Design Benefits. ....	109
16.2 Consequences of Not Using Ergonomic Design .....	109
16.3 Improving the Match of Worker Capabilities to Methods of Work .	109
16.4 Improving the Methods of Work .....	110
16.5 Improving the Materials of Work. ....	110
16.6 Improving the Equipment and Machines of Work .....	112
16.7 Improving the Instruments and Tools of Work. ....	112
16.8 Improving the Organization of Work. ....	112
16.9 Improving the Environment of Work .....	113

---

<b>Section 17: Image</b>	<b>114</b>
17.1 Ergonomic Design Benefits . . . . .	115
17.2 Consequences of Not Using Ergonomic Design . . . . .	115
17.3 Image (Signage, Atriums, Quiet Rooms, Finishes) . . . . .	116
17.4 Cost . . . . .	116
<b>Section 18: Instruments</b> . . . . .	<b>117</b>
18.1 Ergonomic Design Benefits . . . . .	118
18.2 Consequences of Not Using Ergonomic Design . . . . .	118
18.3 Improving the Match of Worker Capabilities to Methods of Work . . . . .	119
18.4 Improving the Methods of Work . . . . .	119
18.5 Improving the Materials of Work . . . . .	120
18.6 Improving the Equipment and Machines of Work . . . . .	120
18.7 Improving the Instruments and Tools of Work . . . . .	120
18.8 Improving the Organization of Work . . . . .	120
18.9 Improving the Environment of Work . . . . .	121
<b>Section 19: Interplant Transfer</b> . . . . .	<b>122</b>
19.1 Ergonomic Design Benefits . . . . .	123
19.2 Consequences of Not Using Ergonomic Design . . . . .	123
19.3 Improving the Match of Worker Capabilities to Methods of Work .	123
19.4 Improving the Methods of Work . . . . .	124
19.5 Improving the Materials of Work . . . . .	124
19.6 Improving the Equipment and Machines of Work . . . . .	124
19.7 Improving the Instruments and Tools of Work . . . . .	125
19.8 Improving the Organization of Work . . . . .	125
19.9 Improving the Environment of Work . . . . .	125
<b>Section 20: Job Safety Analysis</b> . . . . .	<b>126</b>
20.1 Ergonomic Design Benefits . . . . .	127
20.2 Consequences of Not Using Ergonomic Design . . . . .	127
20.3 How, Why, What, Where, Who . . . . .	127
20.3.1 Why . . . . .	128
20.3.2 What . . . . .	128
20.3.3 Where to Start . . . . .	129
20.3.4 Who Does the Analysis? . . . . .	129
20.4 Prioritization of Interventions from Analysis of Data (MSD Related) . . . . .	130
20.5 Success . . . . .	131
20.5.1 Reduce the Physical Demands of the Work Tasks or Job . . .	131
20.5.2 Improve Materials and Objects Handled . . . . .	131
20.5.3 Improve Equipment and Machines, Workstation Layout, and Space . . . . .	131
20.5.4 Improve Instruments, Tools Used, and Objects Handled . . .	131
20.5.5 Work Organization . . . . .	132
20.5.6 Environmental Conditions . . . . .	132

<b>Section 21: Landscaping</b> .....	<b>133</b>
21.1 Ergonomic Design Benefits. ....	134
21.2 Consequences of Not Using Ergonomic Design .....	134
21.3 Gardening Considerations .....	134
21.4 Design of Outdoor Spaces .....	134
21.5 Accessible Facilities .....	134
21.5.1 Accessible Outdoor Spaces .....	134
21.5.2 Rest Areas. ....	135
21.5.3 Benches. ....	135
21.5.4 Signage .....	135
<b>Section 22: Legibility of Forms</b> .....	<b>136</b>
22.1 Ergonomic Design Benefits. ....	137
22.2 Consequences of Not Using Ergonomic Design .....	137
22.3 Improving the Match of Worker Capabilities to Methods of Work .	138
22.4 Improving the Methods of Work on Paper or Online. ....	138
22.5 Improving the Materials of Work. ....	138
22.6 Improving the Equipment and Machines of Work .....	139
22.7 Improving the Instruments and Tools of Work. ....	139
22.8 Improving the Organization of Work. ....	139
22.9 Improving the Environment of Work .....	139
<b>Section 23: Lighting</b> .....	<b>140</b>
23.1 Ergonomic Design Benefits. ....	141
23.2 Consequences of Not Using Ergonomic Design .....	141
23.3 Suggested Lighting .....	141
23.4 Fluorescent Lighting. ....	142
23.5 Changes in the Way of Doing Business. ....	142
23.6 Energy Conservation .....	142
23.6.1 Recent Developments in Lighting .....	142
23.7 Lighting Considerations. ....	143
23.8 Lighting Environments. ....	143
23.9 Natural Lighting .....	143
23.10 Innovations .....	144
<b>Section 24: Maintenance—External</b> .....	<b>145</b>
24.1 Ergonomic Design Benefits. ....	146
24.2 Consequences of Not Using Ergonomic Design .....	146
24.3 Improving the Match of Worker Capabilities to Methods of Work ..	146
24.4 Improving the Methods of Work .....	147
24.5 Improving the Materials of Work. ....	148
24.6 Improving the Equipment and Machines of Work .....	149
24.7 Improving the Instruments and Tools of Work. ....	149
24.8 Improving the Organization of Work. ....	150
24.9 Improving the Environment of Work .....	151

---

<b>Section 25: Maintenance–Internal</b> .....	<b>152</b>
25.1 Ergonomic Design Benefits. ....	153
25.2 Consequences of Not Using Ergonomic Design .....	153
25.3 Maintenance Responsibility .....	153
25.4 How to Reduce Maintenance Costs and Improve Quality .....	153
<b>Section 26: Material Handling</b> .....	<b>156</b>
26.1 Ergonomic Design Benefits. ....	157
26.2 Consequences of Not Using Ergonomic Design .....	157
26.3 Improving the Match of Worker Capabilities to Methods of Work .	157
26.4 Improving the Methods of Work .....	158
26.5 Improving the Materials of Work. ....	158
26.6 Improving the Equipment and Machines of Work .....	161
26.7 Improving the Instruments and Tools of Work. ....	161
26.8 Improving the Organization of Work. ....	162
26.9 Improving the Environment of Work .....	162
<b>Section 27: Material Resource Conservation</b> .....	<b>163</b>
27.1 Ergonomic Design Benefits. ....	164
27.2 Consequences of Not Using Ergonomic Design .....	164
27.3 Waste Management and Material Conservation. ....	164
27.3.1 Objective. ....	164
27.4 Policy Implementation to Manage Resources .....	165
27.4.1 Example: General Guidance in Refrigerants/Safety Risk Air Quality .....	165
27.5 Terminology. ....	165
<b>Section 28: Nanotechnology and Nanomaterials</b> .....	<b>166</b>
28.1 Ergonomic Design Benefits. ....	167
28.2 Consequences of Not Using Ergonomic Design .....	167
28.3 Improving the Match of Worker Capabilities to Methods of Work .	168
28.4 Improving the Methods of Work .....	168
28.5 Improving the Materials of Work. ....	169
28.6 Improving the Equipment and Machines of Work .....	169
28.7 Improving the Instruments and Tools of Work. ....	169
28.8 Improving the Organization of Work. ....	169
28.9 Improving the Environment of Work .....	169
28.10 Notable Sources of Information. ....	170
<b>Section 29: Noise</b> 171	
29.1 Ergonomic Design Benefits. ....	172
29.2 Consequences of Not Using Ergonomic Design .....	172
29.3 Suggested Equipment .....	172
29.4 Acoustics .....	173
29.5 Sound and Its Measurement. ....	173

29.5.1 The Decibel Scale . . . . .	173
29.5.2 Determination of Noise Reduction . . . . .	173
29.5.3 The OSHA Hearing Conservation Standard . . . . .	173
29.5.4 Equivalent Sound Level Contours . . . . .	175
<b>Section 30: Organization of Safety Cultures . . . . .</b>	<b>176</b>
30.1 Ergonomic Mission Statement . . . . .	177
30.2 Purpose . . . . .	177
30.3 Ergonomic Applications . . . . .	178
30.4 Safety Meetings, Activities, and Outcomes . . . . .	178
30.4.1 Safety Meeting Guidelines . . . . .	178
30.4.2 Activity Measures . . . . .	180
30.4.3 Outcomes Measures . . . . .	180
30.5 Responsibilities . . . . .	180
30.5.1 Safety Committee Members: Agendas and Outcomes . . . . .	180
30.5.2 Supervisors . . . . .	180
30.5.3 Employees . . . . .	181
<b>Section 31: Passages . . . . .</b>	<b>182</b>
31.1 Ergonomic Design Benefits . . . . .	183
31.2 Consequences of Not Using Ergonomic Design . . . . .	183
31.3 Circulation System . . . . .	183
31.3.1 Circulation and Interaction Facilities—Typical Functions . . . . .	183
31.4 General Considerations . . . . .	184
<b>Section 32: Personal Protective Equipment . . . . .</b>	<b>185</b>
32.1 Ergonomic Design Benefits . . . . .	186
32.2 Consequences of Not Using Ergonomic Design . . . . .	186
32.3 Improving the Match of Worker Capabilities to Methods of Work . . . . .	186
32.4 Improving the Methods of Work . . . . .	187
32.5 Improving the Materials of Work . . . . .	188
32.6 Improving the Equipment and Machines of Work . . . . .	188
32.7 Improving the Instruments and Tools of Work . . . . .	188
32.8 Improving the Organization of Work . . . . .	188
32.9 Improving the Environment of Work . . . . .	189
<b>Section 33: Pick Patterns and Slotting . . . . .</b>	<b>190</b>
33.1 Ergonomic Design Benefits . . . . .	191
33.2 Consequences of Not Using Ergonomic Design . . . . .	192
33.3 Improving the Match of Worker Capabilities to Methods of Work . . . . .	192
33.4 Improving the Methods of Work . . . . .	192
33.5 Improving the Materials of Work . . . . .	193
33.6 Improving the Equipment and Machines of Work . . . . .	193
33.7 Improving the Instruments and Tools of Work . . . . .	193
33.8 Improving the Organization of Work . . . . .	194
33.9 Improving the Environment of Work . . . . .	194

---

<b>Section 34: Planning</b> .....	<b>195</b>
34.1 Ergonomic Design Benefits .....	196
34.2 Consequences of Not Using Ergonomic Design .....	196
34.3 Sample of Planning a Project .....	196
34.4 Ergonomic Approach to Architectural Design Planning .....	196
34.4.1 Decision-Making Process .....	196
34.4.2 The Process Flow Chart .....	197
34.5 Establishing a Vision .....	198
34.6 User Enrollment .....	198
34.7 Focusing on the Customer .....	199
34.8 Work Modeling .....	199
34.8.1 Building Components .....	199
34.8.2 Risk Assessment .....	200
34.8.3 Skills and Capabilities Assessment .....	200
34.8.4 Grouping Facility Services .....	200
<b>Section 35: Quality</b> .....	<b>202</b>
35.1 Quality Goals for Ergonomic Programs .....	203
35.2 Quality Ergonomics Program .....	204
<b>Section 36: Recycling Operations</b> .....	<b>212</b>
36.1 Ergonomic Design Benefits .....	213
36.2 Consequences of Not Using Ergonomic Design .....	213
36.3 Improving the Match of Worker Capabilities to Methods of Work ..	213
36.4 Improving the Methods of Work .....	215
36.5 Improving the Materials of Work .....	215
36.6 Improving the Equipment and Machines of Work .....	215
36.7 Improving the Instruments and Tools of Work .....	215
36.8 Improving the Organization of Work .....	215
36.9 Improving the Environment of Work .....	215
<b>Section 37: Relocation</b> .....	<b>216</b>
37.1 Ergonomic Design Benefits .....	217
37.2 Consequences of Not Using Ergonomic Design .....	217
37.3 Improving the Match of Worker Capabilities to Methods of Work ..	217
37.4 Improving the Methods of Work .....	218
37.5 Improving the Materials of Work .....	219
37.6 Improving the Equipment and Machines of Work .....	219
37.7 Improving the Instruments and Tools of Work .....	219
37.8 Improving the Organization of Work .....	219
37.9 Improving the Environment of Work .....	220
<b>Section 38: Robots</b> .....	<b>221</b>
38.1 Ergonomic Design Benefits .....	223
38.2 Consequences of Not Using Ergonomic Design .....	223
38.3 Improving the Match of Worker Capabilities to Methods of Work ..	223

38.4	Improving the Methods of Work . . . . .	224
38.5	Improving the Materials of Work . . . . .	225
38.6	Improving the Robotic Interface to Equipment and Machines of Work . . . . .	225
38.7	Improving the Instruments and Tools of Work . . . . .	225
38.8	Improving the Organization of Work . . . . .	226
38.9	Improving the Environment of Work . . . . .	226
<b>Section 39: Safety 228</b>		
39.1	Ergonomic Design Benefits . . . . .	229
39.2	Consequences of Not Using Ergonomic Design . . . . .	229
39.3	Ergonomic Design . . . . .	229
39.4	Fire Protection . . . . .	229
39.4.1	Standpipes . . . . .	230
39.4.2	Sprinklers . . . . .	230
39.5	Minimal Administrative Policies . . . . .	230
39.6	Other Recommended Programs and Policies . . . . .	230
39.7	Safety of Personnel . . . . .	232
39.7.1	Applicable Standards . . . . .	232
39.7.2	Essential Refrigerant Safety Program Aspects . . . . .	232
39.8	Environmental Compliance and Safety . . . . .	232
39.9	Safety and Water . . . . .	233
<b>Section 40: Security . . . . . 234</b>		
40.1	Ergonomic Design Benefits . . . . .	235
40.2	Consequences of Not Using Ergonomic Design . . . . .	235
40.3	Security Inspections . . . . .	235
40.4	Security Services . . . . .	236
40.5	Security Considerations for Smart Cards . . . . .	237
<b>Section 41: Signage . . . . . 238</b>		
41.1	Ergonomic Design Benefits . . . . .	239
41.2	Consequences of Not Using Ergonomic Design . . . . .	239
41.3	Legibility . . . . .	239
41.4	Abbreviations . . . . .	241
41.5	Information Coding . . . . .	241
41.5.1	Information Coding Guidelines . . . . .	242
<b>Section 42: Software . . . . . 243</b>		
42.1	Ergonomic Design Benefits . . . . .	244
42.2	Consequences of Not Using Ergonomic Design . . . . .	244
42.3	Improving the Match of Worker Capabilities to Methods of Work . . . . .	245
42.4	Improving the Methods of Work . . . . .	245
42.5	Improving the Materials of Work . . . . .	246
42.6	Improving the Equipment and Machines of Work . . . . .	246
42.7	Improving the Instruments and Tools of Work . . . . .	246

---

42.8	Improving the Organization of Work . . . . .	249
42.9	Improving the LAN, WAN, and Web Environments of Work. . . . .	249
42.10	ISO Ergonomics Guidelines . . . . .	249
<b>Section 43:</b>	<b>Storage . . . . .</b>	<b>251</b>
43.1	Ergonomic Design Benefits. . . . .	252
43.2	Consequences of Not Using Ergonomic Design . . . . .	252
43.3	Accommodation. . . . .	252
43.4	Americans with Disabilities Act (ADA)—Storage—General . . . . .	253
43.4.1	Clear Floor Space . . . . .	253
43.4.2	Height. . . . .	253
43.4.3	Hardware . . . . .	253
43.5	Shelving . . . . .	253
43.5.1	Shelving Guidelines. . . . .	254
<b>Section 44:</b>	<b>Temperature . . . . .</b>	<b>255</b>
44.1	Ergonomic Design Benefits. . . . .	256
44.2	Consequences of Not Using Ergonomic Design . . . . .	256
44.3	Central Air System. . . . .	256
44.4	Overhead Air Supply . . . . .	256
44.5	Underfloor Air Supply . . . . .	257
44.6	Individual Controls . . . . .	257
44.7	Cooling Demand . . . . .	257
44.8	Heat Loss/Heat Gain Control . . . . .	258
44.9	Passive and Active Solar Heating . . . . .	258
44.10	Enclosure Integrity. . . . .	259
<b>Section 45:</b>	<b>Tools 260</b>	
45.1	Ergonomic Design Benefits. . . . .	261
45.2	Consequences of Not Using Ergonomic Design . . . . .	261
45.3	Ergonomic Approach to Tools. . . . .	261
45.4	Biomechanics of the Hand and Wrist . . . . .	262
45.5	Cause of Cumulative Trauma Injuries . . . . .	262
45.6	Reducing Cumulative Trauma Injuries. . . . .	262
45.6.1	Anthropometrics. . . . .	263
45.6.2	Reducing the Frequency of Repetitions . . . . .	263
45.6.3	Reducing the Force Required . . . . .	263
45.6.4	Eliminating Awkward Postures . . . . .	263
45.7	Selecting the Correct Tool . . . . .	264
45.7.1	Acquiring Tools for Specific Functions . . . . .	264
45.7.2	Tool Size, Weight, and Balance . . . . .	264
45.7.3	Hand Tools. . . . .	265
45.7.4	The Final Selection Process . . . . .	267
45.8	Training. . . . .	267
45.9	Tool Maintenance . . . . .	267
45.10	ANSI B11 Technical Report. . . . .	267

<b>Section 46: Training</b> .....	<b>268</b>
46.1 Why Train? .....	269
46.2 What to Train On: Ergonomic Work Methods. ....	269
46.2.1 Gradual Introduction to Work .....	270
46.2.2 General .....	270
46.2.3 Job-Specific .....	270
46.3 Whom to Train .....	271
46.3.1 Supervisors .....	271
46.3.2 Engineers, Architects, and Maintenance Staff .....	271
46.3.3 Purchasing Personnel .....	271
46.4 Responsibilities of Trained Individuals. ....	271
46.4.1 Employees .....	271
46.4.2 Supervisors .....	272
46.4.3 Organization .....	272
46.5 Questions Organizations Must Answer .....	272
<b>Section 47: Transportation</b> .....	<b>273</b>
47.1 Ergonomic Design Benefits. ....	274
47.2 Consequences of Not Using Ergonomic Design .....	274
47.3 Driver Competencies and Ergonomic Risks .....	274
47.4 Ergonomic Driver Screening Protocol for Transport Vehicles. ....	275
47.5 Ergonomic Driving Interventions .....	276
<b>Section 48: Vendors</b> .....	<b>277</b>
48.1 Ergonomic Design Benefits. ....	278
48.2 Consequences of Not Using Ergonomic Design .....	278
48.3 Improving the Match of Worker Capabilities to Methods of Work ..	278
48.4 Improving the Methods of Work .....	279
48.5 Improving the Materials of Work .....	280
48.6 Improving the Equipment and Machines of Work .....	280
48.7 Improving the Instruments and Tools of Work .....	280
48.8 Improving the Organization of Work .....	281
48.9 Improving the Environment of Work .....	281
<b>Section 49: Waste Management</b> .....	<b>282</b>
49.1 Ergonomic Design Benefits. ....	283
49.2 Consequences of Not Using Ergonomic Design .....	283
49.3 Improving the Match of Worker Capabilities to Methods of Work ..	283
49.4 Improving the Methods of Work .....	284
49.5 Improving the Materials of Work .....	285
49.6 Improving the Equipment and Machines of Work .....	285
49.7 Improving the Instruments and Tools of Work .....	286
49.8 Improving the Organization of Work .....	286
49.9 Improving the Environment of Work .....	286

---

<b>Section 50: Windows</b> .....	<b>288</b>
50.1 Ergonomic Design Benefits .....	289
50.2 Consequences of Not Using Ergonomic Design .....	289
50.3 Solar Control .....	289
50.3.1 Solar Overheating .....	289
50.3.2 Glazings .....	290
<b>Section 51: Summary</b> .....	<b>291</b>
51.1 The Safety Manager's Role in Integrating Ergonomics with Project Management .....	291
51.2 Key Issues for Success .....	291
51.3 The World of Safety Management and Ergonomics .....	292
51.3.1 Demographic and Legal Changes .....	292
51.3.2 Legal Authorities .....	292
51.3.3 Economic Parameters .....	293
51.3.4 Technological Change, Compressed Product Cycles, and Global Competition .....	293
51.3.5 Telecommunications .....	293
51.3.6 Education .....	293
<b>Glossary</b> .....	<b>295</b>
<b>Bibliography</b> .....	<b>305</b>
<b>About the Author</b> .....	<b>323</b>



# Figures

---



Figure I.1.	The brain. . . . .	8
Figure I.2.	Motor and sensory areas of the brain. . . . .	8
Figure I.3.	Basic human skeleton. . . . .	10
Figure I.4.	The muscle system. . . . .	11
Figure I.5.	Structure of the foot. . . . .	12
Figure I.6.	Structure of the neck. . . . .	14
Figure I.7.	Nerve structure. . . . .	15
Figure I.8.	Structure of the eye. . . . .	21
Figure I.9.	Structure of the ear. . . . .	22
Figure 1.1.	Accessibility may be a design issue for multiple users. . . . .	27
Figure 3.1.	Air quality: A Boston fern increases air quality. . . . .	36
Figure 4.1.	Benchmarking criteria. . . . .	41
Figure 5.1.	Proper ergonomic seating design for employees at a computer terminal. . . . .	48
Figure 5.2.	Maintenance of balance. . . . .	50
Figure 5.3.	What chairs must support. . . . .	50
Figure 5.4.	Body support in seated position. . . . .	51
Figure 6.1.	Communication model. . . . .	55
Figure 7.1.	Facility asset management as related to ergonomics. . . . .	61
Figure 8.1.	Stacking people to fit more in the space. Do they require ladder safety training? . . . . .	68
Figure 9.1.	Design of space considers biomechanics and sensory stressors. . . . .	73
Figure 10.1.	Division of space: VDT work surface and range of motion. . . . .	79
Figure 12.1.	Engineering controls have supervision and accommodation integration. . . . .	90
Figure 13.1.	Equipment controls with symbols. . . . .	95
Figure 15.1.	Furnishings can be modified to add access and reduce glare. . . . .	107
Figure 16.1.	Housekeeping requires policy and training for safe action. . . . .	111
Figure 17.1.	Image: An ideal office. . . . .	115
Figure 20.1.	Job safety analysis uses observation, interviews, and test equipment to validate job demands and job risk. . . . .	129

---

Figure 21.1. Landscaping integrates people into the beginning and rest stops of their workday. . . . .	135
Figure 24.1. Workers using shovels safely. . . . .	150
Figure 25.1. Sample routine maintenance schedule. . . . .	154
Figure 26.1. Material handling: Motions. . . . .	159
Figure 26.2. Material handling: Safe lifting. . . . .	160
Figure 29.1. Acoustic absorption rates. . . . .	174
Figure 29.2. Band center frequency in cycles per second. . . . .	175
Figure 30.1. How organizations create work management flow. . . . .	179
Figure 31.1. Passages need to be well marked. . . . .	184
Figure 32.1. Personal protection equipment is job-demand specific. . . . .	188
Figure 33.1. Pick patterns should consider worker reach and balance. . . . .	191
Figure 35.1. Quality and safety require a leadership plan to implement into productivity. . . . .	204
Figure 36.1. Recycling is easy if it is organized. . . . .	214
Figure 37.1. Relocation plan. . . . .	218
Figure 38.1. Robots mimic the range of motion of their human co-workers. . . . .	226
Figure 39.1. Integrated safety management system. . . . .	231
Figure 40.1. Security can be electronically managed. . . . .	236
Figure 41.1. Signage should guide safe actions. . . . .	240
Figure 43.1. Storage should be within reach of all. . . . .	253
Figure 44.1. Temperature and airflow are critical to heating and cooling workspaces. . . . .	257
Figure 45.1. The better the fit to the hand, the better the tool. . . . .	264
Figure 47.1. Transport: Find the “near miss.” Fatigue! . . . . .	275
Figure 48.1. Changing load size to fit workers and just-in-time work makes for the best vendor relations. . . . .	279
Figure 48.2. Work materials analysis . . . . .	280
Figure 49.1. Proper containers allow for the correct management. This looks like a spill ready to happen. . . . .	285

# Preface

---



## The Goal of This Guide

The goal of this guide is to increase the knowledge of safety managers in the use of ergonomics. Four main objectives are pursued:

1. Provide recommendations on the critical sources of data necessary to create ergonomic interventions in areas such as job descriptions, job safety analysis, the human body, and design
2. Provide recommendations about critical ergonomic design factors such that the necessity of including ergonomics in all phases of project management is clearly understood.
3. Identify the necessity of using ergonomics to maintain a competitive edge in order to increase client base and client satisfaction.
4. Provide ergonomic design information to allow engineers, architects, and designers to develop accurate cost comparisons.

In order to fulfill these objectives, this guide provides a review of the human body and its relation to design factors, with statistical information. It is designed to allow the safety manager to evaluate each design factor within the limitations of human beings and project parameters. This guide will help determine:

1. Cost-effectiveness
2. Implementation strategy
3. Human factors issues of productivity, safety, and quality
4. Maintenance and operational outcomes
5. Implementation and integration issues of workers relative to methods, materials, machines, equipment, instruments, tools, organization, and environments

This guide is intended to educate and inform before and beyond job descriptions and the technical requirements of validated job safety analysis. To that end the scope of interventions such as prescreening for competence and the use of engineering controls, supervision, accommodation, and training are reviewed are standardized.



# Introduction

## Ergonomics and Safety Management

---



The risk management goal of safety professionals is to manage facilities so that people can safely accomplish the productivity and quality objectives of their employment. The planning and achievement of productive environments for people is the application of the art and science of ergonomics. Melding the art and the science of production with that of safety management is a cornerstone of response to the demands of ever-increasing statutes, codes, regulations, standards, and laws. The legal trend of workers' compensation and increased sensitivity to the rights of individuals in the workplace (e.g., the Americans with Disabilities Act of 1990 and the ergonomic initiatives of the Occupational Safety and Health Act of 1970) demand an evaluative strategy. Citations for ergonomic violations currently fall under Section 5 of the Occupational Safety and Health Act. Violations continue to add to the cost of doing business.

### The Occupational Safety and Health Act and Ergonomics

Ergonomic violations fall under the General Duty Clause of the Occupational Safety and Health Act of 1970 (29 U.S.C. 654).

Section 5

*(a) Each employer—*

*shall furnish to each of his employees employment and a place of employment which are free from recognized hazards that are causing or are likely to cause death or serious physical harm to his employees;*

*shall comply with occupational safety and health standards promulgated under this Act.*

*(b) Each employee shall comply with occupational safety and health standards and all rules, regulations, and orders issued pursuant to this Act which are applicable to his own actions and conduct.*

## Safety Professionals: Sources of Risk Reduction

Safety professionals are expected to include ergonomics in their risk management programs. To meet their organizational mission, they must have the ability to work within both a legal and a human-factors framework. To create safe work environments, safety professionals must integrate the design of workspaces that support safe actions into the productivity and quality process of work. The most important strategy to creating safe work processes is to apply ergonomic principles to their design. Ergonomic principles capture worker stress relative to force, awkward posture, duration, repetition, and excesses of temperature or vibration. Risk resolution is accomplished when applying human-factor risk management interventions to the method, materials, machines and equipment, instruments, and tools used within organizational guidelines, in environments. Using an ergonomic design process creates clear specifications of “fit to task” requirements. Fitting the task to the person requires data from four sources that guide specifications of safe work processes.

### Competency-Based Job Descriptions

Source 1 is a definition of the job demands by competency. Understanding the competencies required, such as lifting a 45-pound object that must be carried and placed, defines the risk by job actions. But jobs are more than biomechanics. They are composed of interrelated areas that impact safe actions. These areas are knowledge, psychology, biomechanics, sensory concerns, safety, and quality. These competencies define the job and guide both the job safety analysis and physical, sensory, and mental employment screening. Safety professionals use job descriptions to design safe workspaces. Screening is a risk management intervention that matches people’s competencies to job demands by testing to industry standards. Screening should be done based on job competencies for new hires, lateral moves, promotions, and return-to-work planning.

### Job Safety Analysis (JSA)

Source 2 is validated risk analysis data. This data specifies and ranks the ergonomic principles that will work best to fit job tasks to a person’s competencies. For example, a person with farsighted vision is competent to drive a forklift. An ergonomic design factor that supports vision is lighting. The correct lux will prevent near misses and accidents. A person with nearsighted vision is competent to read symbols on a computer monitor. JSA defines what “fitness for duty” actually means relative to a person’s knowledge, psychology, biomechanics, sensory concerns, strength, and stamina. Therefore, source 2 defines the human-factor risk of tasks and how they relate to the ergonomic design of safe work areas. In ergonomics, there are three domains of work: cognitive, psychological, and organizational. A comprehensive JSA has 37 factors that encompass the domains of work. Validated job safety analysis ranks risk by frequency and severity. In this way, a safety professional can determine and prioritize ergonomic interventions to reduce risks that range from catastrophic to remote. Matching job safety analysis data to workplace design reduces risk.

## Understanding of the Human Body

Source 3 is understanding the human body as it relates to specification of work processes. Understanding the limits of the human body from a mental, physical, and sensory perspective is key. For example, knowing how the musculoskeletal system functions in both dynamic and static load postures can help you define reach range limits. Understanding how continuous work with no breaks affects concentration can guide both rest breaks and job rotation as an engineering control. Understanding cumulative trauma can create the necessary link to risk management supervision. Understanding how we hear sounds can help safety professionals be better trainers on why hearing protection is important. Some people, like acclimated Navy SEALs, can work in below-freezing water for more than 40 minutes. Most of us cannot. Similarly, it is rare that a body can adapt to excessive vibration. The point is for safety professionals to design safe work practices with an understanding of the normal functioning of the human body—how the body ages, works under the stress of disease (from the common cold to cancer), disability, and with—or recovered from—injury. The human body is a complex, unique wonder. It is an important aspect of safety management.

## Integrative Design

Source 4 cross-references ergonomic principles with design factors. The goal is to integrate the source value of competency-based job descriptions, job safety analysis, and understanding of the human body into safe work processes. At any time in the safety management process, there are elements of design that can positively impact safety, productivity, and quality. Safety process design is a best-practice strategy. It encompasses human factors of workers and ergonomic principles. The 50 design factors in this guide relate directly to performance expectations. The design factors guide work processes; employment screening; and reasonable accommodation for new hires, lateral moves, promotion, return to work, and succession planning. The design of work for workers is the critical intervention to preventing the risks of occupational illness and injury. Work design becomes an engineering control that reduces awkward postures, force, repetition, duration, and excesses of temperature and vibration. Safety management using these consistent criteria can now evaluate the goal of safety, which effectively meets productivity, safety, and quality criteria for workers. The integrated ergonomic design factors are as follows:

accessibility	effectiveness	job safety analysis
adaptability	energy	landscaping
air quality	engineering controls	legibility of forms
benchmarking	equipment	lighting
comfort	finishes	maintenance—external
communication	furnishings	maintenance—internal
cost	housekeeping	material handling
density	image	material resource
design	instruments	conservation
division of space	interplant transfer	nanotechnology

noise	recycling	temperature
organizations	relocation	tools
passages	robots	training
personal protective equipment	safety	transport
pick patterns	security	vendors
planning	signage	waste management
quality	software	windows
	storage	

## Ergonomics and Design

Ergonomic design in safety management is the application of human-factors engineering to the elements of form (structure) and function (ambience). The physical environment must accommodate the widest range of human functional limitations to enhance the usability of any area. Cost-effectiveness in ergonomics is a result of design incentives. *Good design costs no more than bad design.* For example, operating controls at heights that do not require overreaching makes good ergonomic and economic sense because it reduces the amount of wiring necessary and also lessens installation time. Likewise, energy-efficient task lighting reduces energy consumption and increases the visual acuity of people with limited vision. A well-planned acoustical system in conjunction with the ventilation system can increase creativity and comfort in areas designed for groups of varying numbers. Creating safe environments can include using ergonomics as a guide to choices of flooring and finishes by helping to reduce the number one cause of injury in America: slips and falls.

For exterior entrances, if a main entrance is set 6" above grade, a sloped walkway will meet the needs of most people and reduce the cost of elaborate ramps used to bypass steps. For interior entrances to lobbies and passageways, consider the use of color, textures, and slip-resistant floor finishes; removal of obstructions; and aids for balance. In addition to the gains made for the safety of users, ergonomics can make a facility easier to maintain. By qualifying materials for durability and longevity, injury, repairs, and maintenance are reduced. The overall form and function of a workplace environment can be improved with ergonomically sound design.

Ergonomic designs should be subtle and perceived as an enhancement to the end-users' capabilities. Control over one's environmental comfort and safety is the desired outcome of ergonomics. When ergonomic designs were first introduced, the engineering emphasis was on manufacturing productivity. Now ergonomic designs are available that support safety management goals with effective and attractive solutions meeting compliance guidelines.

The successful safety manager is a team player who will partner with designers and vendors to introduce organizations to ergonomic designs that allow them to be more competitive. A successful safety manager is one who uses technical excellence to balance costs, technologies, and the needs of people to provide an adaptable and flexible environment.

## Designing for Aging, Disability, Disease, and Injury

Most people who have functional limitations still lead active lives. They work and live independently, and engage in social leisure activities. To provide these people with environments that support their work activities, safety managers need to understand their needs. This means going beyond traditional design standards that have been based on normative data of weight, height, age, and range of motion. The design difficulty here is that relying on norms does not take into consideration how the body with functional limitations performs required tasks. That is why it is important to balance design and ergonomics as integral parts of safety management.

### Designing for Aging

The goal here is to design for a decline in strength, stamina, and visual acuity; for gait impairments; and for the limitations of hearing that frequently occur with an aging workforce. The following graphs and figures are illustrative of this need.

During the 20th century, the average life expectancy rate increased at a dramatic rate. In 1900 in the United States, the average life expectancy rate was 47 years. By 1980 it was 75 years, and it has increased slightly since then. This increase in life expectancy means that there are many more aging workers available for the workforce than were present 100 years ago.

**Physical Changes** The physical changes that are experienced during the aging process generally involve mobility, strength and stamina, vision, hearing, and tactile and thermal sensitivity. The degree of change experienced in each of those areas can vary widely. Ergonomic design can increase the sense of orientation by providing appropriate forms of physical support and behavioral cues. Sensory impairment, for example, does not necessarily mean that the worker cannot respond to environmental information. But aging workers may require more reaction time and may need clearer and stronger stimuli to compensate for the loss of sensitivity. The degree to which immediate surroundings promote or hinder appropriate action depends in large part on the severity of sensory losses and the combinations of impairments.

**Mobility** A number of factors—many of them products of a lifetime of physical wear and tear—force many older workers to perform tasks more slowly. Gravity, for example, can gradually overcome our ability to stand perfectly erect, and the stooped posture of aging can itself cause difficulty in walking, sitting down, standing up, and turning. Reductions in ambulatory speed may be caused by a slowed reaction time; low energy levels resulting from such chronic conditions as heart disease; inner-ear damage resulting in a loss of balance or poor feedback about the position of body and limbs; and losses of vision and hearing.

**Strength and Stamina** Strength may decrease with age, but often endurance—or stamina—remains relatively strong. When mobility is hindered, though, reduced strength and stamina are commonplace. Joints normally become more rigid with advancing age. Muscle strength and coordination almost always decrease. Overhead cabinets and

shelves are suddenly beyond reach. Round knobs may become hard to grasp and manipulate. And because once-simple movements may now require more exertion of strength and stamina, distances in both interior and exterior layouts can become important considerations.

**Visual Acuity** Vision begins to decline as early as age 40, and long-term impairment can include loss of visual field and acuity, reduced color sensitivity, and increased sensitivity to glare. Older workers may require up to twice as much light as younger workers to achieve equal visual acuity. Colors of similar intensity are more difficult to differentiate from one another, especially when viewed against similarly textured or reflective surfaces and when viewed under uniform lighting conditions. Pastels, very dark shades, and combinations of blues and greens can be particularly difficult for older workers. These problems can be addressed in ergonomic design through increased illumination levels, increased size for signs, heightened contrast between elements in visually presented information, and the use of highly contrasting colors. Other visual changes occurring in older workers include declines in the ability to see fine detail, to distinguish depth, and to adapt to changes in brightness. Glare is often a major problem; the distraction it causes can affect balance, orientation, attention span, and short-term memory. Glare is often caused by unshielded artificial lighting or by direct sunlight that beams onto a reflective interior space.

**Hearing** Hearing ability often begins to decline noticeably even earlier than visual acuity does. Older workers frequently find it difficult to hear higher-frequency sounds, such as those emitted by bells and by fire and smoke sirens. Designers should always consider redundant-cuing safety systems—systems that issue alarms in both audible (in the lower frequencies) and visible modes, for example.

A decline in hearing also typically makes it difficult for a person to discern one voice or one sound against a background of competing sounds or voices; thus, sound control becomes an important general design issue.

**Tactile and Thermal Sensitivity** Sensitivity to touch naturally and normally declines with age because the skin becomes drier and less elastic. Thus, subtle changes in environmental texture can go unnoticed by older employees. The ability to smell—though not a tactile issue—often declines with touch; sensitivity remains high enough, however, to make odor control important.

Also important among the common tactile losses of aging are declines in immediate sensitivity to pain and temperature.

## Designing for Disability

Americans over the age of 15 with one or more functional impairments represent more than one in every five people, or 37.3 million out of 180 million total population. In addition, the probability of individuals over the age of 65 having difficulty performing a basic activity is four times greater than in individuals between the ages of 15 and 64. The task for safety managers is to check each work area design and product specification to determine the usability, enhancement, and conditions of the

safety provided. For example, a bordered rug can appear to an employee with low vision as if it were a step down. This optical illusion can create an unsafe condition and cause a fall.

### Designing for Disease

Advances in medicine and technology have created the need for environments to support people with diseases through longer periods of life expectancy. A person with heart disease (the third most frequent disease in America), for instance, can live an average of seven more years after triple-bypass surgery. The ergonomic supports for this disease are those that provide comfort (posture and positioning, temperature control, access, and air quality). In the near future, people who are on dialysis machines may be receiving treatments at the work site. This will require quiet rooms with specialized technical supports. Awareness of these impending needs allows managers planning to use benchmark specifications from the health care industry to reconsider the traditional design of work areas.

### Designing for Injury

Today, workers' compensation is one of the most difficult costs for an organization to control. To understand, evaluate, and incorporate design strategies into a management plan is to sustain a competitive edge in a unique manner. For example, supporting maintenance functions with ergonomic designs would reduce the risk of injury in one of the most frequent injury categories. Have you ever tried to change a filter on a heating, ventilating, and air conditioning (HVAC) system? The posture requirements of such a task could challenge a yogi.

## Introduction to the Human Body

In order to understand how ergonomics can affect bodily function, let's review the parts of the body and the various systems that support them.

### The Brain and Central Nervous System

The brain is composed of an enormous number of associated neurons, with accompanying neuroglia, arranged into brain regions and divisions. These neurons receive sensory information, direct the activity of motor neurons, and perform such higher brain functions as learning and memory. Even self-awareness, emotions, and consciousness may derive from complex interactions of different brain regions.

The brain is made up of three main parts—the brainstem, the cerebellum, and the cerebrum. The brainstem controls involuntary actions, such as the heartbeat and breathing. The cerebellum coordinates movements of the muscles so that walking is smooth and balanced. The cerebrum is the largest part of the brain and is divided into two halves or hemispheres.

The outer layer of the cerebrum is a special area that receives messages about sight, touch, hearing, and taste; other areas control movement, intelligence, and personality.

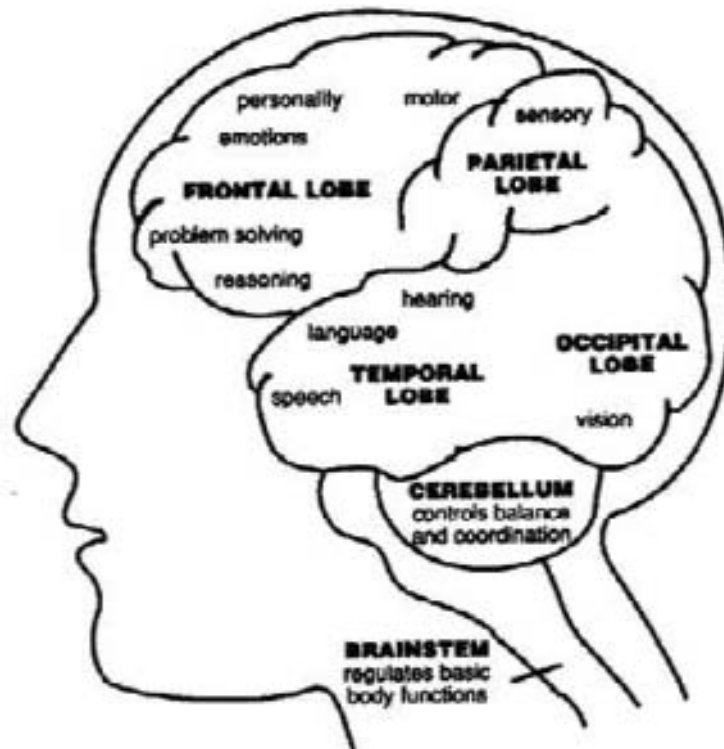

Figure I.1. The brain.

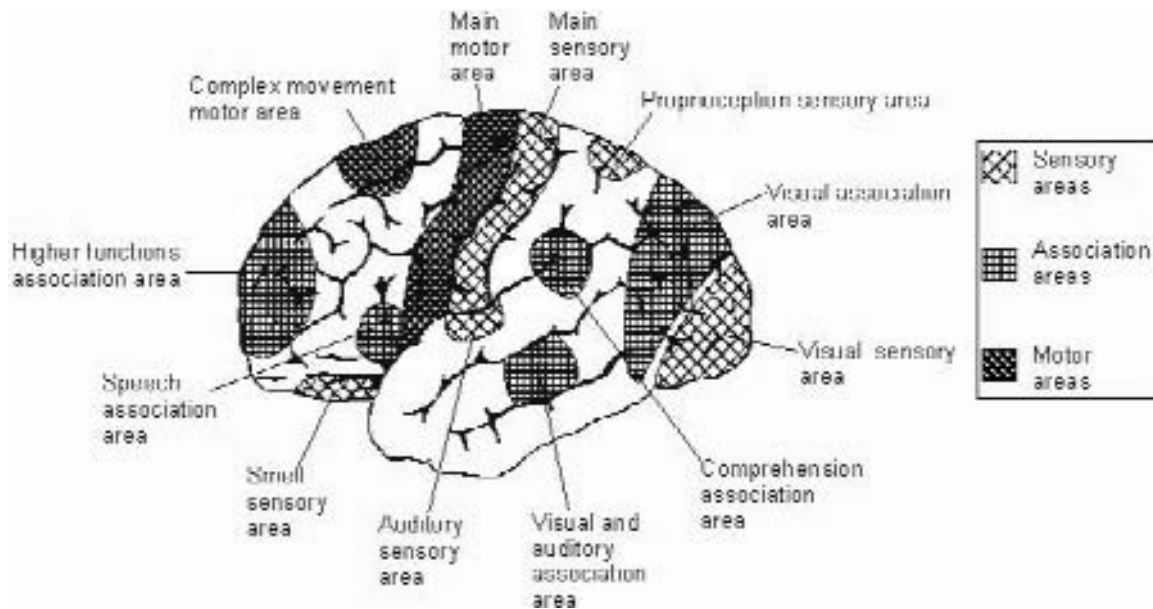

Figure I.2. Motor and sensory areas of the brain.

The central nervous system (CNS) consists of the brain and the spinal cord, both of which are covered with meninges and bathed in cerebrospinal fluid. The nervous system is the body's communication network. Nerves run throughout the body, carrying messages through the spinal cord to the brain—the body's control center.

The brain receives information about the outside world from the nerves. It sorts the information and decides how the body should respond. Information travels along nerve fibers as electrical signals. This information is gathered by the sense organs—skin, tongue, nose, eyes, and ears.

Motor and sensory areas of the cerebral cortex are (a) motor areas that control skeletal muscles, and (b) sensory areas that receive somesthetic sensations.

## Nerves

The neck is the channel connecting the brain with the nerves throughout the body. Spinal nerves branch off from the foramina. Each spinal nerve is “rooted” to the spinal cord with two small nerve roots.

## The Musculoskeletal System

We may think of bones and muscles as different from inorganic materials such as steel or glass, but in many ways they are very similar. Just as excess stress causes glass to shatter, a sudden force can break a bone. Just as the cumulative effects of rust and vibration can cause a steel girder in a bridge to fail, so a lifetime of small injuries can add up to produce osteoarthritis in a joint. We do have a built-in advantage over bridges and buildings because our bones and muscles can adapt to stress. They can remodel their structures, heal when at rest, and be trained to respond more effectively to environmental demands. The bones, joints, muscles, tendons, ligaments, cartilage, and bursas of the human body have evolved sophisticated strategies to respond to varying stresses while supporting us and providing protection for our organs.

Musculoskeletal disorders can be seen as responses to overloads on the body, caused in varying degrees by unhealthy levels of physical stress in the environment. Looked at in this way, prevention of these injuries boils down to reducing the amount of stress to which the system is exposed and/or increasing the amount of stress each system can tolerate through such interventions as exercise, better diet, and improved habits. This is why safety management includes training in such areas as stretch breaks at work; break rooms with healthful food and beverage choices; and job safety analysis techniques.

## Front Skeleton

Under the skin and muscles is the skeleton—a tough, flexible bone structure, which supports and protects the body.

The front part of the skeleton is made up of the face bones of the skull, the collarbones, the breastbone, and the ribs. The hard skull protects the brain, like a shell around a walnut, and the ribs shield the heart and lungs.

Although bones appear hard and dry, they are made up of living cells, blood vessels, and nerves. Most bones have three layers. A thin, tough outer shell, called

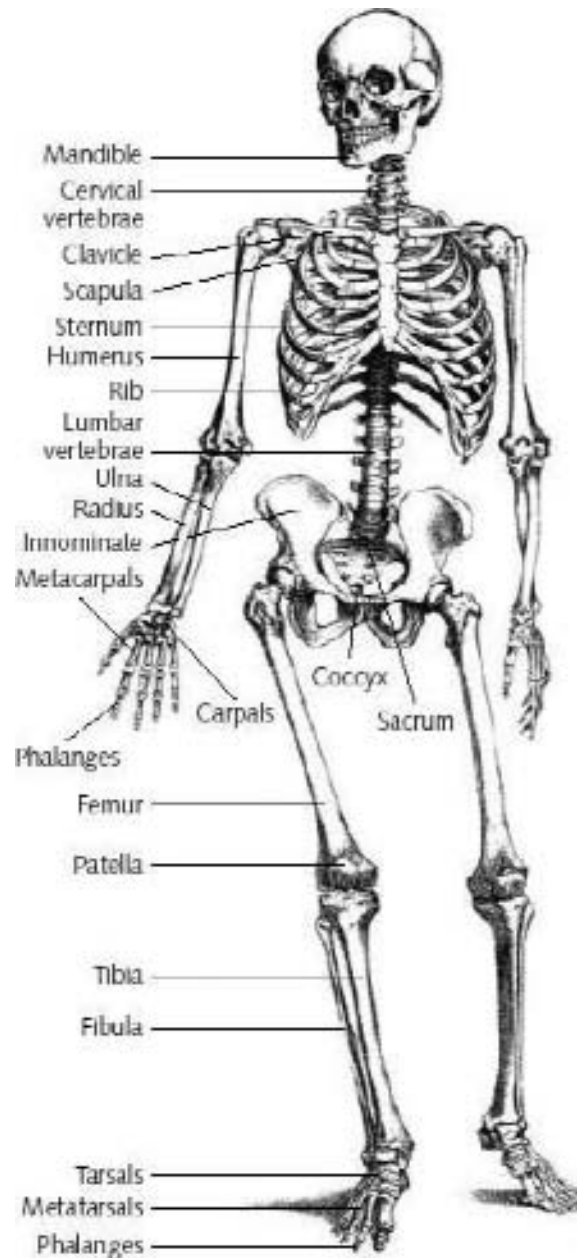

**Figure I.3. Basic human skeleton.**

the periosteum, covers a strong layer of hard bone that surrounds a lighter, spongy core. The periosteum is made of cells that can replace and repair broken bone. This hard layer contains calcium salts that make the bone strong. The inner layer of spongy bone is like a honeycomb, so that the bone is lightweight.

Some larger bones, such as the breastbone and the thighbones, contain a soft, jelly-like substance, called marrow, in the spongy core. Bone marrow can produce as many as 5 billion red blood cells in just one day.

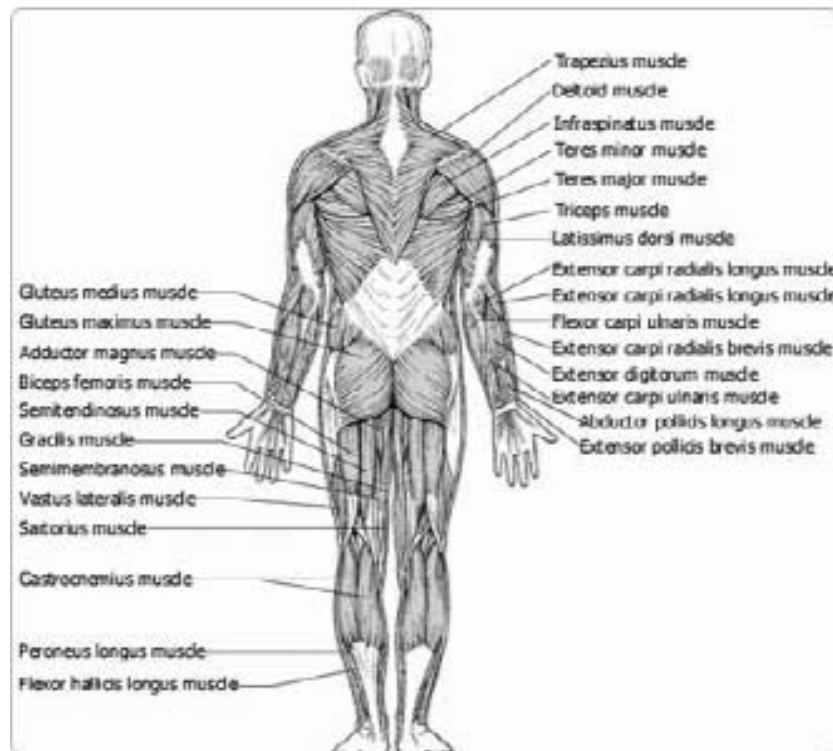
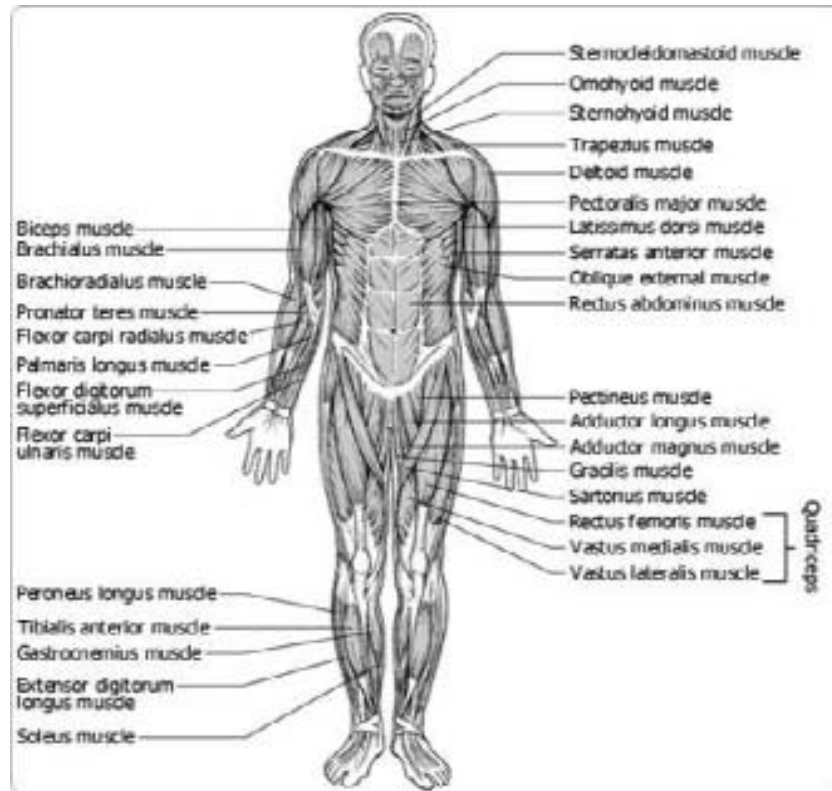

Figure I.4. The muscle system.

## Back Skeleton

The back skeleton gives the body strength. The spine, the pelvis, the arms and legs, together with the front skeleton, protect all the body's important parts. The bones of the back skeleton, with muscles attached to them, enable the body to move.

Bones cannot bend, but where two bones meet they form a movable joint. A smooth tissue called cartilage covers the ends of the bones and protects the bones from wearing away. Around most joints is a sac that contains synovial fluid, which keeps bones from grinding together. Strong elastic fibers, called ligaments, hold the two bones of the joint together. The joint moves when muscles pull on either of the bones.

There are several types of joints that permit different kinds and degrees of motion. Hinge joints, notably in elbows and knees, swing back and forth like doors on hinges. Ball-and-socket joints—the shoulder and hip—allow one bone to twist and turn in many directions while remaining firmly connected to another.

## Bones

The skeleton is living scaffolding that gives the body structure and strength. The 206 bones of the human skeleton not only give the human body its shape and form, but protect delicate organs, such as the heart and the brain; act as reservoirs for essential elements, such as calcium and phosphorous; provide a site for the production of important blood cells; and provide the levers, articulation, and locations for the attachments of muscles that allow movement.



Figure I.5. Structure of the foot.

The bones of the skeletal system are divided into four classifications: long, short, flat, and irregular. The shape of each type of bone suits it to respond to different environmental stresses. For example, the round shape of the skull gives it extra strength to protect the brain, while the bones of the spine thicken as they progress down the back, enabling them to support extra weight.

### Inside the Spine

The spine consists of a set of bones that keep the body upright. Besides the spinal column itself (which protects the spinal cord), there are also small, horizontal bones called the vertebrae, which are separated by soft, tough disks of cartilage that act as cushions between the vertebrae so that the spine can twist and bend.

The vertebrae are classified into five separate regions: the cervical spine (in the neck area—seven vertebrae that support the head and protect the spinal cord on its way up to the head); the thoracic spine (twelve vertebrae, each connected to rib bones); the lumbar spine (five lumbar vertebrae, which are slightly larger than the other vertebrae because they are designed to bear much of the weight of the body); the sacrum or sacral vertebrae (five fused bones at the base of the spine); and the coccygeal vertebrae (four vertebrae that comprise the coccyx, or tailbone).

In their stacked alignment, the vertebrae surround a central canal containing the spinal cord, the major nerve trunk for the body and the seat of reflexes. Also passing through the vertebrae are the nerves leading from the spinal cord to the limbs and other organs. The openings between vertebrae that these nerves pass through can become injured—a common cause of pinched nerves.

### The Neck

The neck (cervical spine) is made up of the top seven vertebrae of the spine. A healthy neck is strong, flexible, and pain free, and the joints of these vertebrae are balanced and aligned with a natural curve. The neck supports the head, protects the spinal cord and spinal nerves, and allows movement of the head in a variety of ways.

The neck moves more than any other part of the spine, and can move in three basic ways. Each of these movements has its own range of motion—the amount of motion that is normally possible. Most neck problems affect the range of motion in some way.

### Vertebrae and Disks

Disks are shock-absorbing pads of cartilage between the vertebrae. Healthy disks have a tough covering, a jelly-like interior, and a certain amount of “give” to adapt to various head and neck movements. The joints in the neck allow movement of the head. Each vertebra joins with the next in two places, giving the spine great flexibility.

### Hip, Thigh, and Knee

The bones of the hip, thigh, and knee are much stronger and heavier than those of the arms, and the muscles that control them are thus much larger. At the hips, two large, flaring bones form the pelvis, a basin-shaped structure that cradles and protects vital

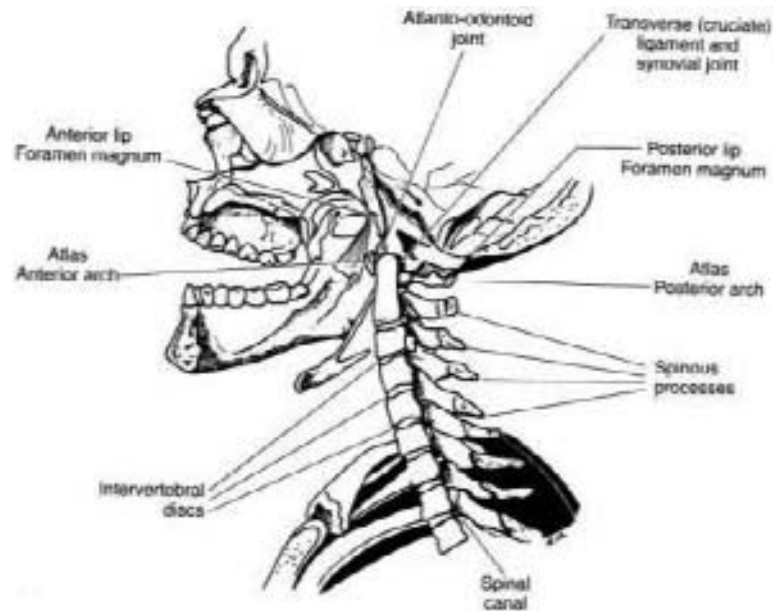

Figure I.6. Structure of the neck.

organs. At the lower end of the pelvis are two large socket joints into which fit the bulbous upper ends of your thighbones—the longest, strongest bones in the body. The thighbones, in turn, fit into the knee joints, which connect the body’s midsection to the shinbones and feet.

### The Foot

The foot is a flexible collection of soft, breakable bones. Yet, it can easily handle the jarring weight of a whole body because all of these bones are held firmly in place by a web of sinewy muscles and strong ligaments that have great tensile strength. This combination of bones and bindings makes for an extraordinarily springy, flexible structure. The wide, flat, bandagelike ligaments that encircle the ankle joints act like the ankle supports an ice skater might wear. As the impact of body weight spreads out through the tarsal bones, the foot’s arch softens the shock, turning it into a “bounce” that makes walking much easier.

When a runner lands on his or her foot, the weight descends from the tibia, a leg bone, into the talus (the ankle bone). The weight is distributed forward to the tarsals and metatarsals and backward to the calcaneus (the heel bone). All of the joints’ surfaces are subject to wear, tear, and arthritis. The arches form a “springy” shock-absorbing system.

### Soft Tissue

Soft tissue includes muscles, tendons, and ligaments. Muscles work together to move and support the head. Tendons are tough tissues connecting muscle to bone. Ligaments are strong bands of tissue that stabilize and connect the vertebrae.

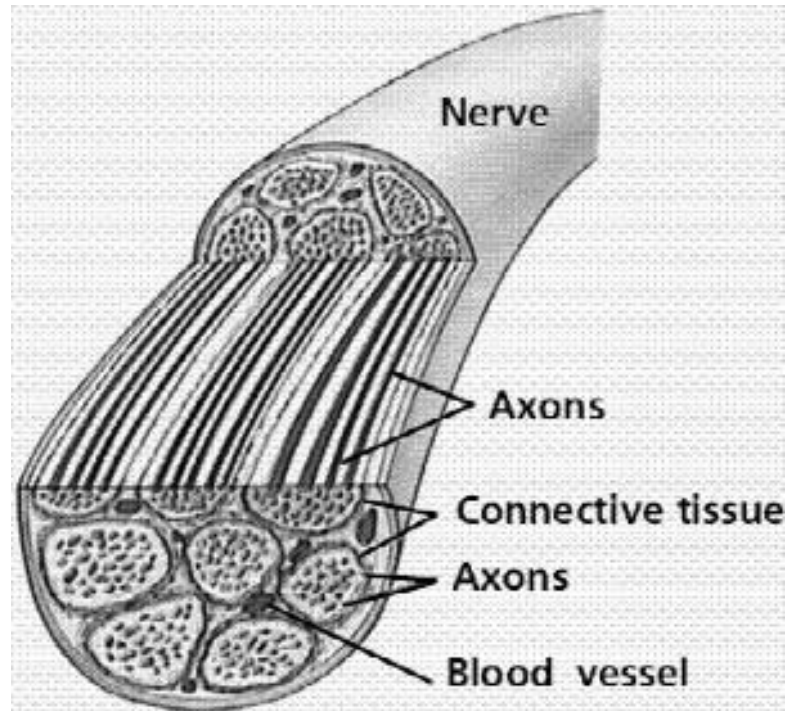

Figure I.7. Nerve structure.

## Muscles

The more than 600 muscles in the human body make movement possible and perform such crucial functions as pumping blood and inhaling and exhaling air. They also generate heat, enable us to sit and stand, and protect bones by absorbing impacts to the body.

The best-known and most common types of muscles—the skeletal muscles—make up about 40 percent of body weight. These muscles are also called voluntary muscles because they are under conscious control. The other two types of muscles—visceral and cardiac—are involuntary muscles that work without conscious control. Visceral muscles are involved in the function of internal organs, such as the stomach, intestines, uterus, and blood vessels. They are not attached to bone, act slowly, and can remain contracted for long periods of time. Cardiac muscles are found only in the heart and make up much of the heart wall.

## Tendons

Tendons are cordlike bundles of fibers found at the ends of muscles that attach muscles to bones. Tendons enable muscles to move the attached bone, sometimes at a distance. Tendon cells are arranged in parallel bundles, which gives them high tensile strength while allowing them to transmit force from muscle to bone without getting damaged. The length of tendons ranges from less than 1 inch to more than 1 foot, the longest being the Achilles tendon, which runs from the heel to the calf.

## Ligaments

Ligaments are long bands of collagen fibers arranged in parallel bundles that hold bones to other bones and give a joint stability, allowing movement in some directions while restricting it in others. Ligaments can be found encircling the hip joint and parallel to the ends of bones in the knee joint, where they provide strength and stability.

## Cartilage

Cartilage is a type of connective tissue made up of specialized cells called chondrocytes, which are embedded in a matrix of varying amounts of collagen. There are three types of cartilage: hyaline cartilage—a tough, smooth tissue that provides a low-friction coating for the bony ends of joints; fibrocartilage—a solid, strong collagen found in the intervertebral disks between the bones of the spine; and elastic cartilage—a soft and rubbery substance found in such places as the outer ear and the epiglottis.

## Joints

The joints, which connect two moving bones together to allow motion and provide stability, have evolved into three types, each with its own biomechanical advantage.

The three types of joints are fibrous joints, such as those in the skull, which have very limited motion and provide stability; cartilaginous joints, such as those between vertebrae, which allow some motion in the spine; and synovial joints, such as those found in the elbow, wrist, and knee, which are the most common type and allow the greatest degree of movement.

The knee is the body's biggest and heaviest joint and seems well armored because it is wrapped in a protective, fluid-filled bag called the synovial capsule. Its parts are lashed together with tendons and ligaments. A stout bony shield—the kneecap—protects it. The thighbone is cushioned from contact with the lower-leg bones by shock-absorbing cartilage. Despite all of this protection, the knee is injured more often than any other joint.

When the knee is either knocked or wrenched out of position, and ligaments either tear or are stretched too far, the kneecap is sometimes dislocated, and the cartilage inside the joint may be damaged. The most dramatic example of knee injury is the blind-side tackle in football, in which a runner's knee is forcibly rammed sideways.

## The Shoulder

Like all joints, the shoulder is composed of many parts. The shoulder joint includes bone, cartilage, a bursa lining, nerves, and many muscles, tendons, and ligaments that hold it together. The shoulder is particularly fragile because its exceptional flexibility and mobility make it vulnerable to wear and tear.

Whether workers are computer operators or plumbers, weekend athletes or cheerleaders, it is the shoulder that allows the arms and hands to function with a wide range of motion.

## Injuries to the Body

### Nerve Root Problems

With nerve root problems, the spinal nerves that pass through the vertebrae in the neck can become stretched, inflamed, or pinched. Workers may experience sharp pain shooting down the arms (often triggered by turning the head), or tingling, weakness, and numbness in the arms and hands. A nerve root problem can be caused by a variety of joint and disk problems, such as facet problems, a ruptured disk, or severe osteoarthritis. Left untreated, further neck or nerve problems can develop.

### Musculoskeletal Ailments

Bones, muscles, ligaments, tendons, and joints are natural marvels of engineering and construction that have evolved over millions of years to provide strength, control, and flexibility. Evolution, however, has not caught up with human invention; our bodies are simply not designed to handle many of the physical stresses of modern life. Activities such as plucking chickens, typing at a word processor, or gliding cans and bottles through the supermarket checkout counter for eight hours each day can tax the human body's musculoskeletal system beyond its capacity to absorb stress, resulting in physical damage.

These days, ailments of bones and muscles due to environmental stresses are extensive. Back pain affects 5.4 million Americans each year, costs \$16 billion annually for treatment, and is cited in 30 to 40 percent of all workers' compensation claims, according to the Office of Ergonomics at the Occupational Safety and Health Administration (OSHA). Overuse disorders—wear and tear on joints and tendons that comes from repeating the same motion hour after hour, day after day—affect six out of every 100 workers. In some industries, such as meatpacking and automobile assembly, more than one-third of the employees complain of these ailments.

### Trigger Points

Trigger points are small, localized areas of pain and muscle spasm, a common symptom of many neck problems. Referred pain may originate in the neck but can be felt nearby in the shoulders, arms, hands, or face. Each muscle has its own pattern of referred pain.

### Degenerative Joint Disease

Pivot joints, such as the wrist, can twist and turn. Hinge joints, such as the knee and elbow, move backward and forward. Ball-and-socket joints, such as the hip and shoulder, allow the greatest all-round movement.

When a spinal joint becomes misaligned or is injured, the vertebrae can't move properly, disks can become compressed, and nerves may be irritated. As degeneration progresses, the disks lose their ability to cushion and the vertebrae can develop bone spurs. Workers may experience pain, stiffness, headaches, and nagging neck aches (often worse in the morning). Joint degeneration is often the result of too much

stress on the joints caused by poor posture, repeated movements, or injury. Left untreated, joint problems can begin to affect the nerves and spinal cord.

If a bone in the lower back isn't moving properly or is out of position, the joint can become inflamed and irritate the sciatic nerve.

### The Shoulder in Trouble

Overuse or underuse of the shoulder can cause pain and stiffness, leading to immobility. This in turn causes muscle weakness and adhesions around the joint, which further limit mobility and cause more pain. And so the cycle goes, until one day the shoulder stops working. Treatment, safe use, and exercise can break the “shoulder in trouble” cycle.

### Knee Problems

The knee is a complex joint where the upper leg bone (femur) and the lower leg bone (tibia) meet. Ligaments connect the bones and help brace the joint by limiting forward and sideways motions and rotation. Muscles, connected to the bones by tendons, provide strength for movement.

The kneecap protects the joint. Repeated strain on the joint, an injury, poor posture, or a misaligned joint in the foot, ankle, or spine can damage the tissue in the knee. This leads to swelling, stiffness, pain, and sometimes locking or “giving way.” Long-term wear, overuse, or a sudden injury, such as twisting the knee, can cause the muscles or tendons to over-stretch or the ligaments to tear. The bones may twist, causing a misaligned joint.

### Unhealthy Spines

An unhealthy spine often starts with an unhealthy habit like poor posture. Standing, sitting, or moving incorrectly puts extra stress on the spine and disks, causing pain. Over time, poor posture can even cause the disks to wear out early. Like wrung-out, brittle sponges, the disks lose their ability to cushion the spine, allowing a wide variety of painful spine and disk problems to develop. Unless corrected, they make the spine more vulnerable to reinjury. Fortunately, ergonomics can prevent and even correct many of these problems by changing worker habits with changes in methods, machine, materials, equipment, tools, and instruments.

Sooner or later, poor posture backfires, causing pain by putting the three natural curves out of alignment. Too much slouching puts pressure on the annulus. A swayback posture can overload and inflame the facets. Muscles tighten and may go into spasm to “splint” the spine, adding to the pain workers feel.

### How Disks Wear Out

Over time, the disks may wear out from natural aging. But poor posture can make them wear out early. As disks narrow and dry out, vertebrae come closer together and become irritated. Bony outgrowths may form, narrowing the foramen and irritating nearby nerves.

## Sciatica

Sciatica is an inflammation of the sciatic nerve, the longest nerve in the body. It runs from the lower spine, through the buttocks, and into the leg and foot. When the sciatic nerve is inflamed, it can cause numbness, tingling, pain, or weakness in the lower back and leg. If one of the cushions between the vertebrae is bulging, it can irritate or put pressure on the sciatic nerve.

## Muscle Spasm

If a muscle in the lower back or buttocks is inflamed or tightening, it can irritate or put pressure on the sciatic nerve.

## Foot and Ankle Problems

The foot is built to withstand motion and pressure. Bones provide the framework. The muscles, tendons, and ligaments (soft tissue) keep the bones stable and control movement. Bones and nerves in the leg connect the foot to the spine. Too many hours on the feet, sudden movements, or misaligned joints can lead to soft tissue and other problems. Sudden sideways movements can tear the ligaments in the ankle. This causes swelling, bruising, and pain.

Flat feet are caused when weak leg and foot muscles cause the arch to collapse or fall. This leads to foot and leg pain, fatigue, and other problems.

## Hand Injuries

The human hand is so sensitive that it can perform brain surgery, so strong that it can twist a screw deep into wood. Underlying the palm are the five cylinder-shaped metacarpal bones, which extend from the wrist to the knuckles. From the metacarpals rise the finger bones—the 14 jointed, flexible phalanges. In all, there are 27 bones in each hand. The bridge between hand and forearm is the wrist, a collection of eight small bones fitted together like cobblestones. These “carpal bones” are bound together in a glovelike structure of strong ligaments.

Primarily strong muscles in the forearm control fingers. These muscles connect with tendons, which are, on the palm side, embedded in long sheaths that extend along each finger. When the forearm muscle contracts, it tugs on the tendon and its sheath, and the finger bends. The thumb contributes to the hand’s flexibility because it is opposed to the other fingers, which permits the hand to pinch a small object between thumb and finger and pick it up.

Carpal tunnel syndrome (CTS) is a common and troublesome condition that interferes with the use of the hand. It is caused when too much pressure is put on the nerve that runs through the wrist. A variety of anatomical abnormalities may be responsible for this viselike pressure. Once symptoms of pain and tingling appear, the condition frequently worsens and permanent nerve damage may occur. However, CTS is highly treatable if diagnosed early.

The pain, numbness, and tingling of CTS can happen anywhere and anytime, at home or at work. But most often symptoms will first appear by waking the worker

up at night. Shaking or massaging the hand may work temporarily, but if ignored, CTS gets progressively worse. The pain increases, the grip weakens, and workers may begin dropping things. Fortunately, appropriate treatment is available.

It's always best to prevent a condition, and CTS is no exception. But if your employees notice symptoms, don't wait for them to become unbearable. The earlier you recommend a professional diagnosis and treatment, the more successful the safety management outcome will be.

### **Strains and Sprains**

Strains and sprains are caused when a joint is forced beyond its normal range of motion, or when muscles that are out of shape or haven't been warmed up properly are overworked. Back strain can occur with a sudden twist of the back or a lift without bending the knees.

A strain occurs when a muscle or tendon is overstretched. Strains are usually caused by putting stress on tight or weak muscles. A sprain is a tear in the ligament. The sudden, forceful twisting of a joint causes sprains. If the tissue doesn't heal properly, the muscles may shorten. This causes the joint to misalign and the nerves to become chronically irritated.

### **Tendonitis**

A tendon is a fibrous cord that attaches muscle to bone. Tendons often must go around sharp corners and through narrow spaces, and are in contact with other points of high wear. Generally there is a bursa, which lubricates the sliding tendon, decreasing the wear present. It may be at one of these joints that bursitis develops, or a condition known as tendonitis may occur.

Tendonitis is inflammation of a tendon. The same basic principles indicated previously in reference to bursitis are present in tendonitis. The only major differences are the tissue involved, the sliding activity of the tendon, and the locations within the body. The same thorough evaluation for the cause of tendonitis is very important in eliminating the condition rather than just overriding its symptoms.

Often overuse is the cause of tendonitis.

### **The Senses and Ergonomics**

Three of the body's most important senses are sight, hearing, and sensation. The eyes and ears receive messages from the outside world and transmit them to the brain. It is critically important to understand how the senses work in order to accommodate for them.

The eye receives light rays that are reflected from an object. Light passes through the pupil and is focused by the cornea and lens. An upside-down picture is formed in the retina. Cells on the retina can sense light and color. These cells turn the picture into electrical signals that travel along the optic nerve to the brain. The brain then decodes the electrical signals, seeing the object the right side up.

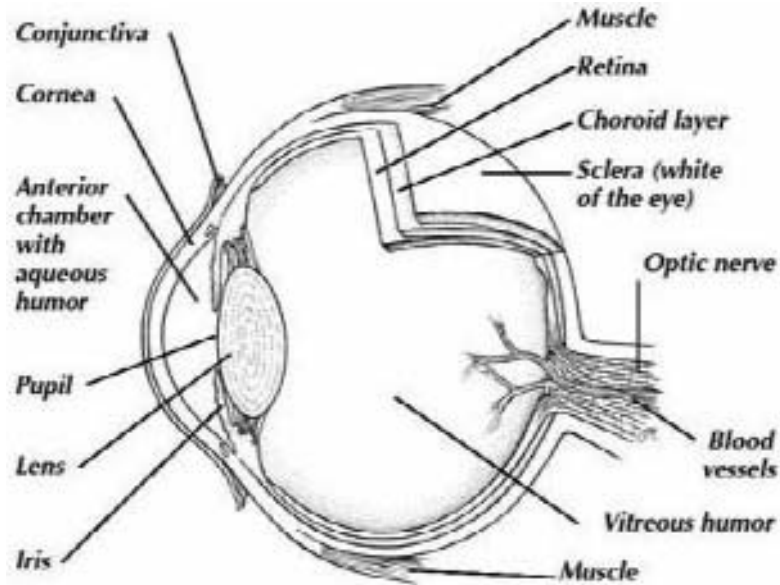

Figure I.8. Structure of the eye.

## Vision

The way that our eyes and brain work together to produce images is incredibly sophisticated. Imagine building a robot that could follow a tiny baseball, hit it at 100 miles (60 km) per hour into the air, and run across a field to make a one-handed catch. The robot would need at least two eyes to see in three dimensions to judge the distance to the ball. But most important of all would be the robot's brain—the computer that interprets the images that the eyes create. When it comes to recognizing images, the human brain is still far more powerful than even the most powerful computers.

The human eye is a tough ball, filled with fluid, sitting in a bony socket. The cornea is the transparent, protective surface of the eye. It also focuses light. The iris controls the amount of light passing through the pupil. It closes up the pupil in bright light and opens it wide in dim light. The lens helps focus light on the retina, which contains a layer of light-sensitive cells. These send signals via the optic nerve to the brain, where they are interpreted to build up our view of the world.

## Hearing

The ear collects waves of sound in the air. Sound waves pass along the auditory canal to the eardrum, making the thin skin of the eardrum vibrate. These vibrations travel through three tiny bones. They are then turned into electrical signals, which travel along the auditory nerve to the brain to interpret them as sound.

Sounds can be loud or quiet, high-pitched (like a whistle), or low-pitched (like a truck engine). Some sounds are pleasant; others are annoying or even painful. But what makes one sound different from another? It has nothing to do with speed. All sounds travel at the same speed. If sounds did travel at different speeds, the sounds of instruments in an orchestra would reach your ears at different times and the music would be jumbled. The answer is that different sounds have different shaped waves.

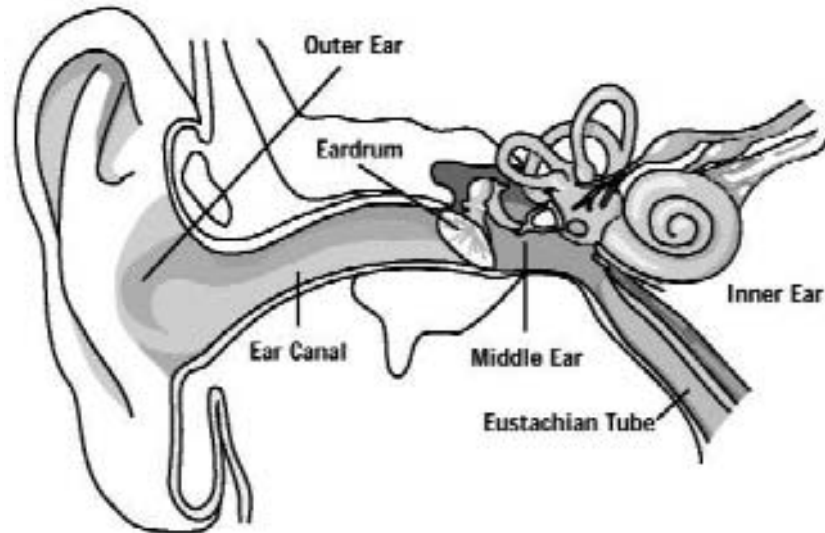

**Figure I.9. Structure of the ear.**

The feature of a sound wave that makes it quiet or loud is called its amplitude. The feature that makes the sound high-pitched or low-pitched is called the frequency and is measured in hertz (Hz). The wavelength—the distance between two wave compressions (crests)—also affects the sound.

The loudness of a sound depends on the intensity (amount of energy) carried by the sound waves. Big vibrations produce intense sound waves with large amplitudes. Very loud sounds, such as sonic booms and shock waves from explosions, can be painful and sometimes cause a lot of damage—the sound waves bang into structures and cause them to vibrate. The degree of loudness is measured in units called decibels.

If you have ever lost your voice, you know how difficult it is to make people understand you without it. Speech is our main form of communication. When we speak, we produce vibrations that travel through the air as sound waves. These sound waves are changed into sounds we can recognize with our ears. Although our ears can detect sounds in the range of 20 Hz to 20,000 Hz, they are most sensitive to sounds with frequencies of around 1,000 Hz. This is the frequency range of voices in normal conversation, although our voices can produce sounds as low-pitched as 50 Hz and as high-pitched as 10,000 Hz. Just as we use our voices to talk to people, animals use sounds to communicate with each other.

## Touch

The human body is covered with an elastic layer called skin. Skin performs many important jobs like holding the body together, keeping water and salts from seeping out of the body, and keeping harmful substances from getting in. The skin also senses touch and temperature.

Skin varies in thickness. It is nearly six times thicker on the soles of the feet than it is on the eyelids. Skin varies in form, too. The skin around the elbows and knees is loose to allow them to bend. The skin on the palm of the hand is firm and ridged so that it can grip.

Look at your fingertips under a magnifying glass and you will see that they have a pattern of ridges. These are your own unique set of fingerprints. The ridges are formed before you are born and no one else has the same pattern.

The skin is made up of different layers. The outside of the skin, called the epidermis, is a layer of flat, dead cells. These cells contain keratin to make the skin waterproof and tough. The cells are constantly being worn away and are replaced by new cells that move toward the surface and harden. Other cells produce a special pigment called melanin. Melanin darkens the skin and protects it from strong sunlight.

Under the epidermis is a thicker, more elastic layer called the dermis. Here, sebaceous glands produce an oily substance, which helps keep the skin and hair soft and waterproof. Thread-like nerves can sense pain, touch, temperature, and pressure. Blood vessels, hair follicles, and sweat glands all help control body temperature.

When the body is too hot, blood vessels widen, bringing more warm blood nearer the skin's surface. The air outside cools the blood. Sweat glands produce moisture, which dries on the skin to cool down the body. When the body is cold, the blood vessels narrow. Goose pimples form when tiny muscles contract to push hairs up on end to trap the warm air next to the skin. Beneath the dermis is a layer of fat that helps keep the body warm and stores energy.

## A Factor Analysis Approach to Safety Management and Ergonomics

The 50 factors presented in the sections that follow include all those design and human factors that should be considered in creating productive and safe environments. The factors support the productive, efficient, and safe use of space. The understanding and organization of these factors is meant to allow you to “study the elephant one part at a time.” However, the ultimate goal is to understand the factors as part of a matrix of factors that continuously interact with one another. In other words, no one factor stands alone. “Even though we’re looking at big ears, *it’s still an elephant.*”

The understanding that ergonomics is multidisciplinary is obvious. The following 50 factors are presented to guide your decisions on safe work practices. Safety professionals using these factors and ergonomic principles can guide the many professions—design engineers, production engineers, industrial designers, computer specialists, industrial physicians, health and safety practitioners, and specialists in human resources—to work in support of risk management. The overall aim is to ensure that our knowledge of human characteristics is brought to bear on practical problems of people at work. We know that in many cases humans *can* adapt to unsuitable conditions, but such adaptation often leads to inefficiency, errors, unacceptable stress, and physical or mental cost. We want to avoid risk and manage it with sound principles of ergonomics that improve productivity, safety, and quality.



## Human Factors to Be Considered Related to Job Competencies

### Knowledge

- Methods of work
- Materials
- Machines and equipment
- Instruments and tools
- Organization
- Environment

### Psychology

- Concentration
- Fatigue
- Emotions

### Biomechanical

- Balance, coordination
- Full range of motion
- Sitting
- Standing
- Head
- Upper extremities
- Lower extremities

### Safety

- OSHA
- ANSI
- CDC
- GHS
- EPA

### Strength and Stamina

- Lift, carry, place, transfer
- Materials, objects, people
- Weight
- Height, width, length

### Sensory

- Vision
- Hearing
- Olfactory
- Skin
- Taste
- Speech

### Quality

- ISO
- Six Sigma

The importance of accessibility in ergonomics is to consider the optimum locations of both static work components (e.g., bookshelves, large machines) and dynamic work components (e.g., controls, seating, materials). Accessibility to these components should be considered when they are used by individuals to perform tasks. The objective of ergonomic accessibility is to evaluate each component's accessibility relative to the unique human factor needs of the individuals or groups using that component.

Biomechanical needs should be considered based on the position a person must assume to effectively be mobile within a space, manipulate objects and equipment, and participate in work-related activities. For example, components should be arranged in a workspace by frequency of use—with the most frequently used components within the easiest reach. Sensory needs should also be considered in order to accommodate eye-hand interaction. Psychological needs should be considered to support productivity and safety. Additionally, components that are organized by function are less stressful. For example, all components used for quality testing on a single product should be accessible on the same workbench. Intellectual needs should be considered to support productivity and quality by creating access to components in the optimum sequence of use and by importance. For example, assembly parts organized in a left to right semicircle are arranged in a familiar pattern. Accessibility is the optimum location of work components in relation to the employee performing the tasks.

### 1.1 Ergonomic Design Benefits

- Improved design
- Improved safety
- Legal compliance

### 1.2 Consequences of Not Using Ergonomic Design

- Lost time
- Increased cost
- Legal citation
- Injury, illness
- Disease
- Fatality
- Lost quality

### 1.3 Importance of Accessibility

- People spend 70% of their workday in their work area, typically at their workstation moving within a three- to five-foot radius.
- People with an assigned work area typically spend 30% of their time away from their work area (10% of this in another person's area, 27% resourcing their tasks, 18% in conference rooms, and 45% off their floor of location).

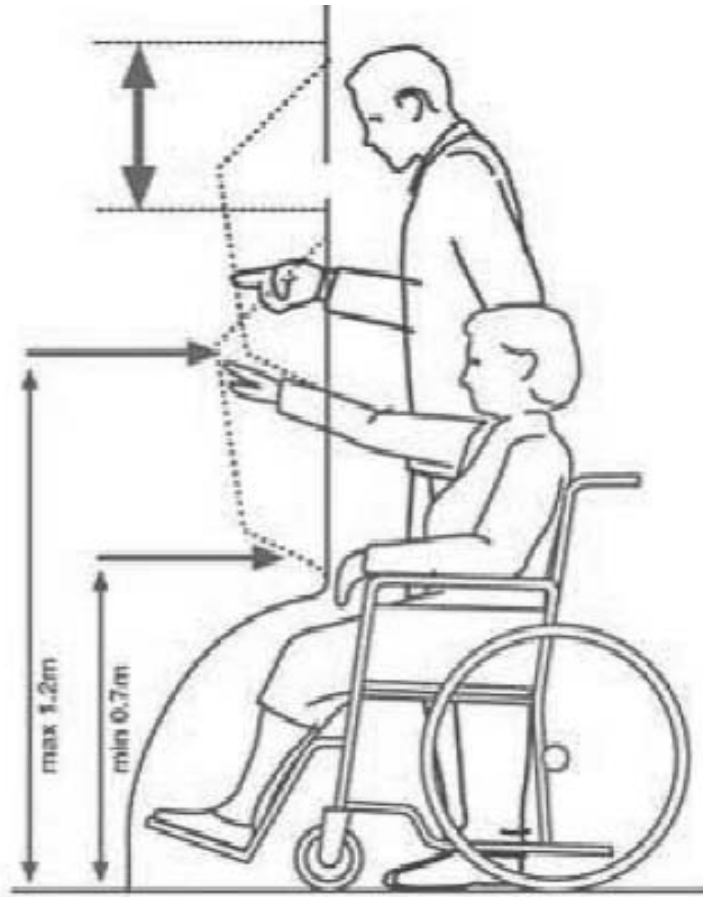

Figure 1.1. Accessibility may be a design issue for different users.

#### 1.4 Accessibility Guidelines

- ❑ Orient the work area so that the employee can face the work without twisting, turning, or bending.
- ❑ Make sure the work surface height accommodates work type and visual requirements (see table 1.1). Angle the work surface to enhance visual acuity.
- ❑ Build in adjustability. If unable to adjust, then design according to population percentiles: Establish work surface height for 50th to 95th percentile worker. Establish reaches and shelf/conveyer heights for 5th percentile female (smallest worker).
- ❑ Orient all incoming/outgoing products and materials for easy access in (correct angle) and to (correct height).
- ❑ All side movements should be down and out, within 14"–18" reach, and at working height or slightly below.

**Table 1.1 Work surface heights for various tasks**

<i>Work Type</i>	<i>Work Surface (in reference to elbow height)</i>
Delicate, fine work (writing, assembly)	2–4 inches above
General handwork	2–4 inches below
Manual work, using tools	4–6 inches below
Heavy manual work, using the back and legs	6–16 inches below

- ❑ Design areas so that movement occurs in the same horizontal plane. All objects to be manipulated should be arranged so that the most frequent movements occur with the elbows bent and close to the sides.
- ❑ For optimal hand/arm strength and skill, work should be placed 10"–12" in front of eyes, and elbows should be bent at an 85°–100° angle.
- ❑ If objects need to be higher and closer for visual acuity, use supports under them. These supports should be padded and adjustable.

## Human Factors to Be Considered Related to Job Competencies

### Knowledge

- Methods of work
- Materials
- Machines and equipment
- Instruments and tools
- Organization
- Environment

### Psychology

- Concentration
- Fatigue
- Emotions

### Biomechanical

- Balance, coordination
- Full range of motion
- Sitting
- Standing
- Head
- Upper extremities
- Lower extremities

### Safety

- OSHA
- ANSI
- CDC
- GHS
- EPA

### Strength and Stamina

- Lift, carry, place, transfer
- Materials, objects, people
- Weight
- Height, width, length

### Sensory

- Vision
- Hearing
- Olfactory
- Skin
- Taste
- Speech

### Quality

- ISO
- Six Sigma

The importance of adaptability in ergonomics is to consider the optimum flexibility of the components of work as they relate to both the structural dimensions of the body (such as height and weight) and the functional dimensions of the body (such as reach or mobility). Adaptability is determined by evaluating the relationship between the flexibility of components in a space and the widest range of human capabilities within that space. An example of biomechanical adaptability is the ability to raise or lower the height of a work surface to meet the needs of people whose torsos range from 30" to 45". An example of sensory adaptability is the ability to control lighting in a room. An example of intellectual adaptability is the ability to design and redesign the sequence of movements, given the limitations of a piece of equipment. Adaptability provides for the optimum flexibility of workplace components for employees.

## 2.1 Ergonomic Design Benefits

- Improved productivity
- Improved safety
- Legal compliance

## 2.2 Consequences of Not Using Ergonomic Design

- Lost time
- Increased cost
- Poor quality

## 2.3 Importance of Adaptability

- Technology continues to enhance human capability.
- Changing environments and changing personal needs due to aging, injury, disease, and disability are critical to adaptability.

## 2.4 Ergonomic Adaptability

- Design work areas, surfaces, and tools with technologies that are integrated into other key design factors and that satisfy the expectations of *both the supervisor and the employee*.
- Employers need to know if the work site design makes the best use of the following:
  - aesthetics and image
  - ease of maintenance
  - function and fitness
  - lowered first costs and life cycle costs
  - responsiveness of a status marking system
  - bulk purchase agreements or existing inventory
- Employers need to know if the room satisfies the following criteria while meeting corporate standards, laws, and guidelines:
  - appearance
  - comfort
  - ease of communication

- ease of participation
- flexibility
- layout
- occupancy level
- relocation frequency
- safety (rules posted)
- grounded equipment
- no extension cords
- safe smoking areas
- secure rugs
- Both employees and employers need to know if the room provides an atmosphere that does the following:
  - increases opportunities for individual choice
  - encourages independence
  - compensates for changes in perception and sensory acuity
  - decreases unnecessary mobility
  - encourages social interaction
  - stimulates participation in activities offered
  - reduces conflict and distraction
  - provides a safe environment
  - makes activities accessible
  - improves employer and employee image
  - allows for growth and change in individuals

## 2.5 Design Recommendations

Taking into consideration the environmental design and specific individual design factors of work environments, workstations and work technologies are uniquely designed for individual capabilities. These quality check recommendations illustrate the range of customized options that increase productivity while reducing stress and fatigue.

- Are tasks performed more efficiently?
- Are productivity rates maintained or exceeded?
- Are stressors diminished?
- Have muscular stressors been eliminated?
- Have injuries and symptoms been reduced?
- Is the physical relationship with equipment well integrated for the employee?
- Are accessories within easy reach?
- Are there resources for doing the tasks?
- Has the intensity of concentration required been reduced?
- Is the environment totally accessible?
- Have the individual's limitations been mitigated by well-integrated interventions?
  - example: access plane for SMART Card and lighting
- What effect have the adaptations/interventions had on other employees and supervisors?

## Human Factors to Be Considered Related to Job Competencies

### Knowledge

- Methods of work
- Materials
- Machines and equipment
- Instruments and tools
- Organization
- Environment

### Psychology

- Concentration
- Fatigue
- Emotions

### Biomechanical

- Balance, coordination
- Full range of motion
- Sitting
- Standing
- Head
- Upper extremities
- Lower extremities

### Safety

- OSHA
- ANSI
- CDC
- GHS
- EPA

### Strength and Stamina

- Lift, carry, place, transfer
- Materials, objects, people
- Weight
- Height, width, length

### Sensory

- Vision
- Hearing
- Olfactory
- Skin
- Taste
- Speech

### Quality

- ISO
- Six Sigma

The importance of air quality in ergonomics is to consider the optimum air purity for unique individuals and groups in the workplace environment. The difficulty in maintaining air quality is the range of human responses to air contaminants that may or may not be regulated by OSHA exposure limits but nevertheless cause physiological reactions. Increasingly, individuals in work environments are complaining of reactions to perfumes, secondary smoke, off-gases from copying machines, and so forth. Some common physiological reactions include runny nose, itchy eyes, and headaches. Therefore, an ergonomic evaluation needs to go beyond regulated air pollutants such as smoke, exhaust fumes, toxic vapors, gases, insecticides, herbicides, and ionizing radiation and consider “discomfort” as a valid indicator of the need to investigate and resolve air quality concerns. The question then becomes what degree of concentration and exposure time to what “pollutants” is an acceptable exposure.

### 3.1 Ergonomic Design Benefits

- Increased fresh air
- Improved comfort
- Improved safety
- Legal compliance

### 3.2 Consequences of Not Using Ergonomic Design

- Lost time
- Increased cost of energy
- System failures
- Legal citations
- Injury, illness
- Disease
- Fatality
- Lost quality

### 3.3 Air Quality and Ergonomic Design

- Employees need the following:
  - increased exposure and access to outdoor landscaped spaces
  - clear views with season and time-of-day indications
  - natural ventilation with the effective distribution of fresh air
- Safety managers must review air distribution and exhaust and the selection of enclosure materials to reduce off-gassing and unwanted moisture migration (with resulting condensation and bacterial growth).
- In addition, review:
  - operable windows, linkages, air intakes, and exhausts
  - cross-ventilation with side, top, or filtered openings
  - roof monitors, stack, and suction ventilation
  - mechanically assisted ventilation
  - displacement ventilation

- night ventilation, flywheel effect
- access to outdoor work and break areas
- indoor plants

### 3.4 Ergonomics and Defining Fresh Air Architecture

- A wide range of approaches to providing more healthful air quality in workplaces has been demonstrated in Japan, Germany, North America, the United Kingdom, and France. The air quality approaches range from innovations in building systems to innovations in operational attitudes.

### 3.5 Eight Major Categories of Innovation Deemed Critical to the Emerging Definition of Fresh Air Architecture

- Innovative heating, ventilating, and air conditioning (HVAC) system designs
- Maximized individual control of environmental systems
- Increased outside environmental contact for the individual
- Effective pollution source control
- Demonstration of concern for the environment and building resource management
- Demonstration of concern for the effectiveness of the building systems
- Demonstration of concern for the health, comfort, and satisfaction of the occupants
- Relationship of air quality to productivity

### 3.6 Factors Affecting Indoor Air Quality

- There are four factors that affect indoor air quality:
  - HVAC systems
  - interior and exterior pollutant or contaminant sources
  - pollutant pathway
  - building occupants
- Indoor air should not contain contaminants that reach or exceed concentrations known to impair health or cause discomfort to building occupants. Such contaminants include:
  - various gases, vapors
  - microorganisms
  - smoke
  - other particulate matters

These contaminants may be present already in outside air or be introduced from indoor activities, furnishings, building materials, surface coatings, or air handling and air treatment components.

#### 3.6.1 Indoor Contaminants

- Existing contaminants must be maintained below the levels shown in table 3.1.

**Table 3.1 Maximum contaminant levels**

<i>Contaminant</i>	<i>Maximum level</i>
Asbestos	< .01 fibers/cm <sup>3</sup>
CO <sub>2</sub>	< 1000 ppm
CO	< 35 ppm
Formaldehyde	< .1 ppm
Lead dust or fumes	< .15 mg/m <sup>3</sup>
Nitrogen dioxide	< 3 ppm
Radon	< 4 pc/liter
Sulfur dioxide	< 2 ppm
Particulate	< 10 mg/m <sup>3</sup>
Tobacco smoke	< .1 mg/m <sup>3</sup>
Penicillin	< 500 cfu/m <sup>3</sup>
Cladosporium	< 500 cfu/m <sup>3</sup>

- ❑ Building occupants play a major role in maintaining air quality. Air contaminants are introduced into the air by:
  - perfume
  - tobacco smoke
  - personal hygiene products
  - foods
  - plants and pesticides
  - copy machines
  - office supplies
  - some work-related activities
  - other non-work activities
- ❑ Air movement and heating, ventilating, and air conditioning loads are affected by the presence of electronic equipment, by furniture design, and by space layout.
- ❑ HVAC control is affected by adjusting thermostats and ducts.

Based upon this information, the Federal Division of Buildings and Policy Services developed a comprehensive program to ensure that each building's air quality meets the requirements of safety and comfort, while maintaining efficient energy use. The building management and staff recommendations included the following:

- ❑ Conduct periodic CO<sub>2</sub>, humidity, and temperature testing to ensure comfort and safety.
- ❑ Install computerized building management systems to efficiently maintain and monitor HVAC control.
- ❑ Develop an automated preventive maintenance work order system to ensure efficient HVAC operation.
- ❑ Periodically evaluate and adjust HVAC air balance for proper air movement.



**Figure 3.1. Air quality: A Boston fern increases air quality.**

### 3.7 More Healthful Enclosure Design for the Workplace

- Maximize environmental contact by:

Increasing periphery and eliminating buried high-use spaces.

Installing high-visibility-transmission glass.

Allowing for direct access to the outside, with outside work/meeting/eating areas.

#### 3.7.1 Design Provisions

- Layered, dynamic envelope provisions include:
  - solar load control with exterior shading devices
  - light and glare control with interior shading devices
  - heat loss gain/control; high R-value facades and roofs
  - low balancing with water mullion system
- Passive air conditioning provisions include:
  - day lighting (with ambient and task control)
  - natural ventilation (cross, stack, and fan assist with passive ventilation)
  - passive solar heating potential in low interior load conditions
- Air freshness provisions include:
  - dedicated 20 cfm outside air
  - air supply independent of thermal demand
  - operable windows for natural ventilation (a five-minute purge cycle)
  - air quality filters on supply side, distributed for access
  - steam humidification on air side; ultrasonic individual units on water side
- Negotiated control provisions include:
  - individually controlled air speed, temperature, direction, OA content, and MRT
  - thermal energy monitoring, including individual “odometers”
- Passive and active ventilation provisions

#### 3.7.2 Ventilation

Natural ventilation and its integration with the mechanical system may be the hardest to engineer, quantify, and integrate into the modern office.

Natural ventilation in office environments requires pressure differences for cross-ventilation and suction ventilation, or temperature differences for stack ventilation, to create a natural air movement through the workplace.

Displacement ventilation relies on the natural horizontal migration of slightly cooler air to provide for the fresh air ventilation needs of the workplace (not the cooling needs).

Night ventilation relies on the lower nighttime air temperatures to cool down the mass in the building's structure (concrete slabs, for example) and provide an effective heat sink for the internal gain buildup the following day.

Care must be taken not to overcool the building mass below dew point so that no condensation and potential bacterial growth can occur.

## Human Factors to Be Considered Related to Job Competencies

### Knowledge

- Methods of work
- Materials
- Machines and equipment
- Instruments and tools
- Organization
- Environment

### Psychology

- Concentration
- Fatigue
- Emotions

### Biomechanical

- Balance, coordination
- Full range of motion
- Sitting
- Standing
- Head
- Upper extremities
- Lower extremities

### Safety

- OSHA
- ANSI
- CDC
- GHS
- EPA

### Strength and Stamina

- Lift, carry, place, transfer
- Materials, objects, people
- Weight
- Height, width, length

### Sensory

- Vision
- Hearing
- Olfactory
- Skin
- Taste
- Speech

### Quality

- ISO
- Six Sigma

**B**enchmarking describes the practice of comparing products, services, and methods with those of other organizations and companies known to be leaders in their fields. The objective of benchmarking is to identify and adapt the leaders' best practices or procedures. Understanding benchmarking provides a competitive edge in creating a safer and healthier environment based on the highest quality practices. Ergonomics improves productivity, safety, and quality.

#### 4.1 Ergonomic Design Benefits

- Legal compliance
- Improved comfort
- Improved safety

#### 4.2 Consequences of Not Using Ergonomic Design

- Lost time
- Increased cost of energy
- System failures
- Legal citations
- Injury, illness
- Disease
- Fatality
- Lost quality

#### 4.3 Importance of Benchmarking

- Benchmark areas may include:
  - cost of workers' compensation
  - cost of occupational health nurse
  - cost of ergonomic assessment

##### 4.3.1 Possible Areas for Benchmarking

- Extent of training programs' success
- Use of computerized maintenance programs
- Size of offices or workspace cubicles
- CAD utilization
- Food services
- Furniture inventory
- Landscape, flooring, and asphalt maintenance
- Use of blanket purchase orders
- Staff size
- Cost per square foot for construction/remodeling for safety
- Safety
- Use of just-in-time (JIT) inventory for material handling
- Churn rates

### 4.3.2 Areas of Interaction

- Headcount
- Environmental responsibilities
- Gross square footage occupied
- FM ergonomic budgets
- Ownership of space
- Charging for space and services
- Vacancy rate of space
- Contracting services
- Churn rate
- Use of computer applications
- Space allocation policies
- Storage of graphic assessment information

### 4.3.3 Structure of the Safety Department

- Use of performance indicators
- Reporting structure
- Communication with building users' current property issues

## 4.4 Suggested Tasks for Implementation of a Benchmarking Study

- Establish a local benchmarking group of safety managers with other companies or other institutions of similar mix and size.
- Participate in the American Society of Safety Engineers (ASSE) national benchmarking process, and others as appropriate.
- Receive periodic (at least annual) benchmarking comparative reports from the safety council group.
- Create ongoing focus groups of the participating companies, to share and implement ideas for continuous improvement.
- Encourage participation by all levels of the safety management organization.

### 4.4.1 Implementation

Benchmarking is practiced by comparing one department within an organization to a similar department in a different corporation/institution, no matter the type of industry. This is key to successful measurement.

## 4.5 The Measurement Process

- Most organizations, especially those in manufacturing areas, have found ways to measure processes. Many companies have adopted specific ways of measuring—for example, statistical process control (SPC). Identified below are some of the more common methods of measurement that could be applied to your facilities or organization to establish a measurement process.



Figure 4.1. Benchmarking criteria.

#### 4.5.1 General Measurement Processes

- Customer satisfaction surveys
- ISO 9000 requirements
- Baldrige steps
  - benchmarking (internal, external)
- Matrices planning
- Statistical process control (SPC)
- Hoshin planning
- Value engineering (design)
- Earned process value
  - skills assessment
- Deming's 14 steps and 7 sins
- Quality functional deployment
- Total productive maintenance (TPM)
- Key driver determination
- Deming's plan/do/check/act (PDCA)

## 4.6 ISO 9000

- ❑ In 1987, the International Organization for Standardization (ISO) adopted the ISO 9000 series quality system management standards. The major factor driving worldwide use of the standard is the unification of 12 major European nations into a single trading union called the European Economic Community.

### 4.6.1 ISO Standard Is a Twofold Opportunity

- ❑ ISO registration will soon be a European requirement.
- ❑ The discipline required for ISO 9000 enhances and improves existing quality systems, especially in written standards and procedures.

## 4.7 Areas of Interest in Ergonomic Planning

- ❑ Section 1.0—Management Responsibility
  - Responsibilities, job descriptions, and qualifications are documented properly and available for review or audit within the department.
- ❑ Section 4.0—Document Control
  - Documentation is authorized, dated, and signed with revision level control and history.
- ❑ Section 5.0—Purchasing
  - Procedures for qualification and assessment of subcontractors are documented.
- ❑ Section 10.0—Inspection, Measuring, and Test Equipment
  - All equipment used in facilities on the master Corporate Calibration List is inspected, measured, and tested.
- ❑ Section 12—Control of Non-Conforming Product
  - Procedure for handling supplier non-conformance is documented.
- ❑ Section 13—Corrective Action
  - Procedure for initiating, tracking, and following up on corrective actions is documented.
- ❑ Section 16—Internal Quality Audits
  - Records of internal audits are maintained.

## 4.8 Quality Measures

- ❑ External image
- ❑ Worker satisfaction
- ❑ Supplier evaluation (recommended by ergonomists)

## 4.9 Financial Measures

- ❑ Accounts payable
- ❑ Budgets
- ❑ Revenue/square footage (return on investment)

#### 4.10 Timeliness Measures

- Project delivery time
- Downtime

#### 4.11 Productivity/Efficiency Measures

- Safety/security
- Teams of designers and technicians
- Information technology
- Worker utilization
- Innovation
- Education
- Planning
- Environmental practices
- Products and/or services
- Process for legal compliance
- Technology
- Organizational structure
- Historic growth, workers' compensation reduction trends
- Revenue per person or revenue per area
- Competition
- Problems with existing conditions
- Inventory distribution of ergonomic products
- Finance/accounting systems and methods
- External environments

#### 4.12 Locations and Their Components

- Locations
  - properties, sites, and buildings ownership/lease data
  - amount (gross, rentable, usable)
  - classification of usage (category, type, and standard)
  - occupancy/ownership status
  - physical condition and functional performance for corporate mission
- Primary systems
  - foundations
  - substructure
  - exterior closure
  - roofing
- Secondary systems
  - partitions and doors
  - walls and furniture
  - floor finishes
  - ceiling finishes
- Service systems
  - conveying
  - conveying for material handling

- Service systems
  - mechanical
  - plumbing
  - heating
  - cooling
  - lighting
  - power
- Safety standards
- Energy conservation
- Handicapped access
- Functional standards
- Financial performance (operational costs)
- Legal restrictions
- Personnel access to safety services
  - personnel identifiers
  - position standard
  - location
  - telephone number
  - organization unit
  - activity
- Furniture/equipment recommendations
  - open-plan components (by standard)
  - freestanding units (by standard)
  - large or expensive pieces
  - requirements
  - adjacencies
- Telecommunications

### 4.13 Goals for a Safety Project

Goals for a safety project must meet and comply with:

- Corporate vision
- Corporate audit
- Strategic and tactical plans
  - the facility forecast
  - corporate communication information
  - how any of the following will affect the corporation
- Economic conditions
  - national
  - international
- Demographics
- Markets
  - site locations
  - labor pools

- Workforce
  - women
  - minorities
  - immigrants

#### 4.14 Workforce Statistics

- By the year 2020, two-thirds of the American workforce will be minority or female.
- In 1985, 47% of the workforce was American-born white males; by 2000, this was down to 15%.
- Immigrant men and women made up 7% of the workforce in 1985, and 22% of the workforce in 2000. This trend is expected to increase.
- Women of all cultures represented almost half of the workforce by 2000.
- Over 600,000 immigrants will enter the country each year in the foreseeable future. This will affect the following:
  - marketing and distribution of products
  - financial policies
  - telecommunications and computer needs
  - expectations for employee welfare and health and safety policies
  - physical environment and aesthetics of locations
  - social, cultural, and educational opportunities in the workplace
  - political trends
  - ecological trends
  - technological trends

#### 4.15 More Healthful Interior Design for the Workplace

- Design changes
  - low off-gassing and low-radiation materials (furniture, walls, carpets, fabrics, paints, adhesives)
  - selection of recycled and recyclable materials
  - renewable materials
  - easily maintained materials
  - high-integrity materials
- Construction changes
  - remote outgassing of delivered products
  - reduced pollution “sinks” during construction
  - direct outdoor exhaust continuous during construction
  - no fast-track occupancy
- Operation changes
  - dedicated exhaust at service hubs and relocatable office exhausts
  - low-pollution products (computers, toners, cleaners)
  - recycling of office products
  - plants as filters, oxygenators, and mood uplifters
  - occupancy questionnaires
  - complaint response
  - diagnostic evaluations, embedded, robotics, transportable

## Human Factors to Be Considered Related to Job Competencies

### Knowledge

- Methods of work
- Materials
- Machines and equipment
- Instruments and tools
- Organization
- Environment

### Psychology

- Concentration
- Fatigue
- Emotions

### Biomechanical

- Balance, coordination
- Full range of motion
- Sitting
- Standing
- Head
- Upper extremities
- Lower extremities

### Safety

- OSHA
- ANSI
- CDC
- GHS
- EPA

### Strength and Stamina

- Lift, carry, place, transfer
- Materials, objects, people
- Weight
- Height, width, length

### Sensory

- Vision
- Hearing
- Olfactory
- Skin
- Taste
- Speech

### Quality

- ISO
- Six Sigma

The importance of comfort in ergonomics is to keep in mind this one truth: People are not “typical” or “average”—they come in different shapes and sizes; vary in age; come from a variety of different cultures; and are likely to have a range of diseases, disabilities, injuries, and physical considerations. With that in mind, ergonomic designs should allow employees to be comfortable while using equipment, tools, and materials. Seating, entries with key systems, and toilet facilities are also important comfort considerations.

## 5.1 Ergonomic Design Benefits

- Improved productivity
- Improved safety
- Legal compliance

## 5.2 Consequences of Not Using Ergonomic Design

- Lost time
- Legal citation
- Injury, illness
- Disease
- Fatality
- Lost quality

### 5.2.1 Increased Workers' Compensation Claims (percent increase)

Back injuries	99.19%
Carpal tunnel syndrome	86.26%
Repetitive motion, cumulative trauma	76.21%
Work-related stress (psychological)	39.52%
Needle sticks or other puncture wounds	36.69%
Head injuries	35.08%
Heart problems	25.00%
RSD syndrome (continuous pain)	19.76%
Exposure to toxicity/hazardous substances	17.34%
Asbestos exposure	8.47%
Lead exposure (lead-based paint, etc.)	3.23%
Lyme disease	3.23%
Other	15.32%

### 5.2.2 Results of Muscles Working at Maximum Capacity

- Inflammation and injuries, which result in pain
- Swelling
- Diminished range of motion

### 5.3 Use of Telephones

#### 5.3.1 Suggested Telephone Techniques and Purchases

- Use handheld telephone.
- Alternate sides.
- Purchase a rest.
- Purchase a headset.

#### 5.3.2 Caution

- Worker should always avoid holding the telephone receiver with the ear and shoulder.

### 5.4 Proper Chair Adjustments with Footrest

- Minimize muscle activity to maintain posture.
- Reduce disk pressure to spine.
- Maintain load bearing to the chair, not the body.

### 5.5 Seating

- Adjust height to maintain feet flat on the floor.
- Incline backrest and seat angle.
- Provide back support to lumbar.
- Adjust armrests to support weight to the arms.
- Shorten seat pan to prevent pressure on veins in thighs.
- Fit seat pan to ischia.

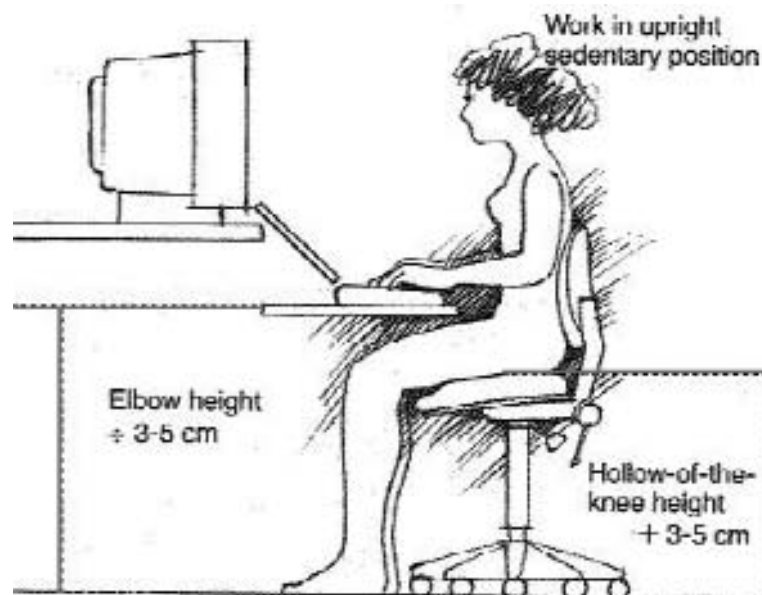

Figure 5.1. Proper ergonomic seating design for employees at a computer terminal.

## 5.6 Footrests

- Tilt angle adjusts knee angle to slightly above pelvis to aid circulation and reduce stress to the heart.
- Foot pedals decrease static load to the muscles of the legs and thighs.
- Flat platform adjusts knee angle or levels the foot for access.
- Warming pads reduce the discomfort of cold floors that can aid in such diseases as arthritis and post-polio syndrome.

## 5.7 Seating and Comfort

- Because of the uniqueness of each employee's body and the stresses on it due to hours of sitting, proper seating is one of the most important ergonomic interventions a safety manager provides.
- The goal of all ergonomic interventions is to maintain productivity and efficiency while reducing stress and fatigue. Proper seating therefore becomes one of the more difficult purchases.

### 5.7.1 Postural Supports

Seated postures require a minimum of five integrated postural supports:

- Feet to supported surface (footrest or floor) with wheelbase and support cylinder
- Leg, buttocks, and trunk support through seat pan and backrest
- Lumbar spine support through seat pan and backrest's lumbar support
- Shoulder and arm support through backrest and chair arm supports
- Head and neck support through backrest and chair arm supports

### 5.7.2 Maintenance of Balance

- The height from the floor to the seat pan is critical for workers to integrate their bodies with their workstations, equipment, and materials.
- The back can work twice as hard maintaining posture when a seat is either too high or too low, in order to compensate for pelvic rotation. In addition, the maintenance of "safe movement" reduces the likelihood of overreaching for materials.
- A minimum of five to six caster bases is recommended with braking casters.

### 5.7.3 What Chairs Must Support

- Chairs must provide support that maintains the lumbar spine and pelvis in the naturally curved position in order to reduce pressure on the disks.
- Lumbar supports must transfer the person's weight from the spine to the support in order to reduce disk compression and the possibility of injury and pain.

### 5.7.4 Body Position

- Chairs must allow for changes in body position in order to reduce the static load on the back and trunk and reduce muscle fatigue and pain.

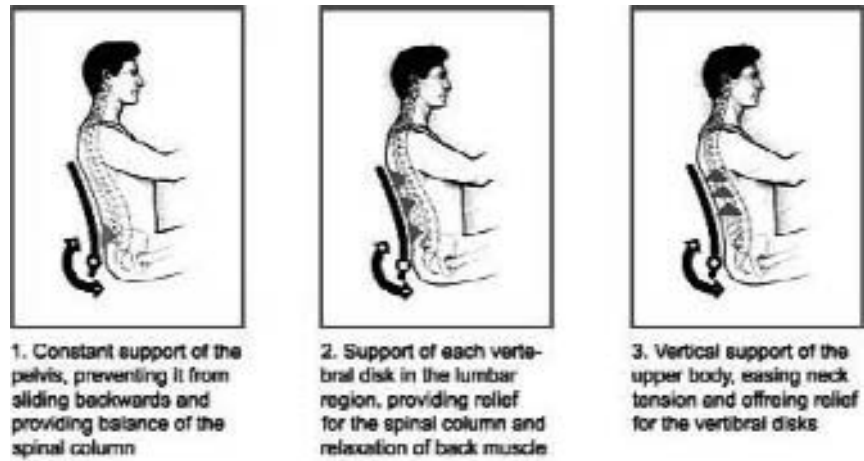

Figure 5.2. Maintenance of balance.

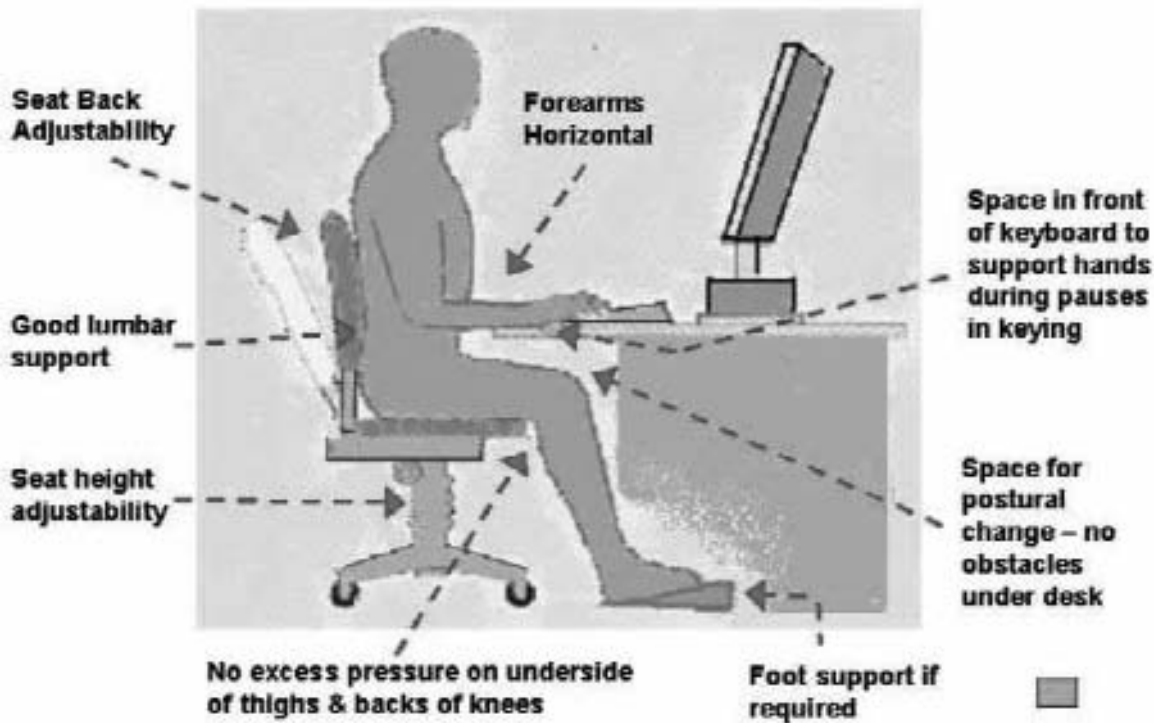

Figure 5.3. What chairs must support.

- ❑ The employee must be able to adjust the chair's height to varying work surfaces.
- ❑ Forearm supports at the level of the work surface are needed in order to reduce disk pressure and muscle strain.

#### 5.7.5 Seat Pan

- ❑ The seat pan of a chair must be flexible enough to allow for load changes and the compression of buttocks and thighs in order to reduce pressure under the thigh, reduce stiffness, and reduce the heart working harder to pump blood through the circulatory system.

#### 5.7.6 Backrests

- ❑ Backrests must incline in tandem with the seat pan in order to promote the proper support of the body, to reduce dependence on the muscles and spine, and to maintain good posture.

#### 5.7.7 Footrests

- ❑ Footrests should be used to take the pressure off the thighs and raise the knees above the level of the hips.



**Figure 5.4. Body support in seated position.**

## 5.8 Integration of Seating with Workstation Task Design

- ❑ Chairs should meet the work surface with armrests to allow a level forearm support to the surface.
- ❑ Work surface from chair access should be large enough to support the keyboard, mouse, monitor, and documents. Not having enough space for the mouse to be adjacent to the keyboard is, unfortunately, one of the most commonly observed ergonomic hazards.
- ❑ The chair should allow for the top line of the screen to be slightly about midline. This keeps the neck straight. (Adjustable arms, tables, or platforms can help bring the screen to the proper height.) Screens that tilt vertically and swivel horizontally help the worker select the best viewing angle. Monitors should be placed 18"–30" away from the worker for viewing. The distance depends on the size of the monitor, the use of corrective lenses, and visual acuity, among other factors.
- ❑ Keyboards and monitors should be detachable so the angle and position can be adjusted. Keyboard, chair arms, and work-surface edges should be rounded to prevent contact stress.
- ❑ Documents should be between the keyboard and the monitor in line with the hands on the keyboard. The screen and document should be easily viewed so that the worker's head does not have to turn to the side or tilt up or down regularly.
- ❑ To prevent glare, the monitor and keyboard should be perpendicular to windows and between (not directly under) overhead lights. If this is not possible, then adjustable window coverings should be installed to reduce backlighting and/or glare. Covers can be used.
- ❑ Screen contrast and brightness should be easily adjustable.
- ❑ Screen characters should be clearly displayed, neither wavy nor flickering. The refresh rate on the monitor should be set at 72 Hz, or higher if possible.
- ❑ Wrist/palm rests may be used to protect wrists and palms from hard or sharp edges and to help keep the wrists in a neutral position. However, continually resting wrists on a wrist/palm rest during keying can put pressure on nerves, or in other words be a source of contact stress.
- ❑ Wrist/palm rests should be made of soft but supporting material and be the same height as the front edge of the keyboard.

## Human Factors to Be Considered Related to Job Competencies

### Knowledge

- Methods of work
- Materials
- Machines and equipment
- Instruments and tools
- Organization
- Environment

### Psychology

- Concentration
- Fatigue
- Emotions

### Biomechanical

- Balance, coordination
- Full range of motion
- Sitting
- Standing
- Head
- Upper extremities
- Lower extremities

### Safety

- OSHA
- ANSI
- CDC
- GHS
- EPA

### Strength and Stamina

- Lift, carry, place, transfer
- Materials, objects, people
- Weight
- Height, width, length

### Sensory

- Vision
- Hearing
- Olfactory
- Skin
- Taste
- Speech

### Quality

- ISO
- Six Sigma

The ergonomic importance of communication in the workplace is to consider communication key to productivity, safety, and quality. While the means of communication continues to change—from speech and words on paper to beepers, faxes, phones, e-mail, cell phones, answering machines, and digitized boards, to name a few—the ergonomic initiative remains to categorize the means and the messages of communication and to develop conditions that increase the favorability of speaking and listening conditions. Some suggested solutions include using quiet rooms, earphones, headsets, acoustical treatments, and baffles on machines, and training talkers and listeners to accommodate their environments to their communication needs.

### 6.1 Ergonomic Design Benefits

- Improved productivity
- Improved safety
- Legal compliance

### 6.2 Consequences of Not Using Ergonomic Design

- Legal citation
- Injury, illness
- Disease
- Fatality
- Lost quality

### 6.3 Goals of Ergonomic Communication

- Maximize interaction.
- Encourage communication.
- Remove impediments to productivity.
- Provide convenient and comfortable work environments that optimize an employee's time for conducting tasks.
- Encourage employees to remain on-site.
- Reduce the research and production development cycle time.
- Enhance recruiting.
- Provide support services in the most cost-effective manner.
- Create a competitive advantage.
- Extend the endurance and creativity of people.

### 6.4 Operational Considerations of Communication

- Appropriate support services in facilities can improve communication patterns. There is also evidence that the level of communication impacts on organizational performance.
- Typically, 60% of the technical information for a project is communicated through informal meetings.
- Performance is proportional to the level of interaction among colleagues within the organization.

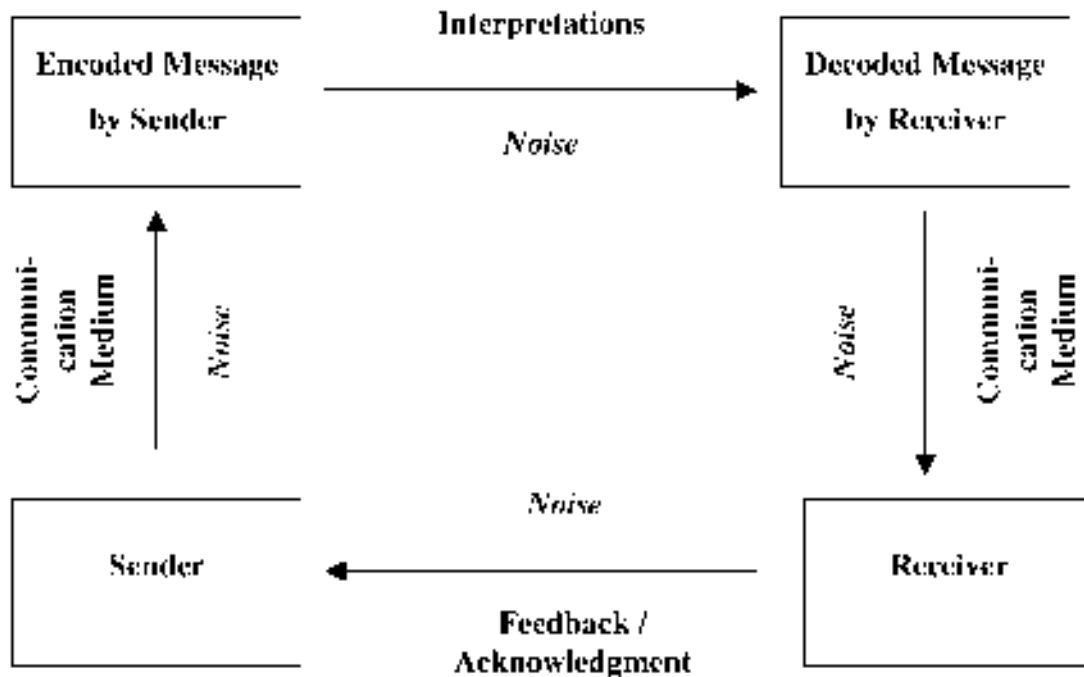

Figure 6.1. Communication model.

- Interaction with colleagues outside of the immediate project team is conducive to higher performance.
- The distance separating workers is the most important factor in determining the likelihood of communication among them.
- In general, most daily communication among workers occurs within a distance of 30 meters of their work area.
- Group affiliation (by department or project team) also increases the likelihood of communication. Distance has the same effect on a group area as an individual area.
- Vertical separation is as much of a deterrent as horizontal separation. People are just as reluctant to use an elevator or climb stairs as they are to walk down a hallway.

## 6.5 Supports and Service Amenities Critical to Communication

- Transportation and parking services:
  - employee
  - visitor
  - other
- Public and visitor services:
  - employee entrance (dedicated security)
  - visitor entrance
  - exhibits/displays
  - clients demonstration/presentation
  - culture center

- Meeting and assembly services:
  - project rooms
  - conferencing
  - video conferencing
  - training
  - auditorium/large group assembly
  - cafetorium
- Technical information services:
  - library
  - document control/records management
  - publications
  - translation
  - self-paced learning rooms
  - private rooms
- Employee and convenience services:
  - medical facilities
  - fitness center
  - showers and locker rooms
  - child care
  - dormitory
  - convenience/company store
  - bank/ATM/credit union
  - travel agent
  - beauty shop/barber shop
  - laundry service
- Food services:
  - kitchen and serving
  - dining areas
  - vending machine areas
  - kitchenette facilities
  - coffee bars
- Circulation and interaction facilities:
  - atriums and passages
  - walkways
  - nodes/lounges
  - courtyards
- Information and communication system services:
  - computer center
  - data networks
  - telecommunications
  - power supply
  - television and video control center
- Office and laboratory services:
  - audiovisual equipment
  - printing and copying
  - office supplies

- model shop
- glass shop
- glass washing and storage
- laboratory supplies
- ❑ Material handling services:
  - shipping and receiving
  - warehousing
  - chemicals and hazardous materials
  - recycling
  - mail and package delivery
- ❑ Security and safety services:
  - control center
  - security station
  - guards
- ❑ Building and site services:
  - FM-CADD/CAM
  - building control room
  - custodial and janitorial
  - building/grounds maintenance
  - outdoor recreation/jogging trail

## Human Factors to Be Considered Related to Job Competencies

### Knowledge

- Methods of work
- Materials
- Machines and equipment
- Instruments and tools
- Organization
- Environment

### Psychology

- Concentration
- Fatigue
- Emotions

### Biomechanical

- Balance, coordination
- Full range of motion
- Sitting
- Standing
- Head
- Upper extremities
- Lower extremities

### Safety

- OSHA
- ANSI
- CDC
- GHS
- EPA

### Strength and Stamina

- Lift, carry, place, transfer
- Materials, objects, people
- Weight
- Height, width, length

### Sensory

- Vision
- Hearing
- Olfactory
- Skin
- Taste
- Speech

### Quality

- ISO
- Six Sigma

The importance of cost effectiveness in ergonomics is to evaluate the effectiveness of vended products, hardware, procedures, equipment, and personnel within the context of an organizational system. It is important, in other words, to verify that “they do what they say they do.” The evaluation of worker interface with tools and equipment determines the effect of these on the higher potentials of human performance. Cost effectiveness can be evaluated by experimental procedures, such as definition of a hypothesis, and manipulation of conditions to evaluate performance and job routines. Test conditions can be developed to simulate as closely as possible what would naturally occur in a real work situation. Of particular interest in ergonomics is the study of worker profiles that represent the population of workers in real situations with attendant stresses and strains. An adequate number of repeated observations or trials must take place in order to give a valid and reliable representation. Cost effectiveness in ergonomics is the evaluation of performance, not price.

### 7.1 Ergonomic Design Benefits

- Improved design
- Improved safety
- Legal compliance

### 7.2 Consequences of Not Using Ergonomic Design

- Lost time
- Increased cost
- Legal citation
- Injury, illness
- Disease
- Fatality
- Lost quality

### 7.3 Cost-Related Decisions That Must Be Made

- Cost of ergonomics
- Choice among equipment purchase options
- Decisions about whether to replace or repair equipment
- Determination of the value of more efficient ergonomic equipment
- Comparison of in-house versus outsourced ergonomic services
- Comparison with other company investment opportunities

### 7.4 Formula of Value

- Fortunately, when a basic formula of present value, average annual cost, and internal rate of return is calculated with a computer spreadsheet, the safety manager is able to reach a decision quickly and accurately.
- Computer spreadsheets are valuable because they provide the present value, the average annual cost, and the internal rate of return, plus tax depreciation and expected escalation of costs.

## 7.5 Goal

- ❑ The goal of cost effectiveness is to provide the safety manager with a working knowledge strategy of financial analysis tools combined with a spreadsheet that will convert annual cash flows into numbers suitable for comparison.

## 7.6 Objectives

- ❑ An understanding of these terms:
  - present value
  - average annual cost
  - internal rate of return
- ❑ The ability to calculate and determine when to use each of the above
- ❑ An understanding of how to use the provided spreadsheet stating the estimated annual costs over the life of the items involved

## 7.7 Developing an Estimate

- ❑ Because it relates to ergonomic costs (space planning, furniture, and equipment), developing an elemental estimate is the obvious starting point for developing an estimate. This estimate takes on added significance in ergonomics because it quickly becomes a purchasing document to be used for negotiation of contracts with selected vendors to verify price competitiveness. It is during the actual implementation process that financial management plays its greatest role.

### 7.7.1 Areas of Financial Management

- ❑ Establish a project cost accounting system to monitor and control the total ergonomic project cost.
  - The system tracks costs associated with various work packages, such as space planning, furniture, and electrical equipment, as well as major components within these areas.
- ❑ Evaluate changes to determine if they are part of the project scope and recommend a course of action, including determining financial responsibility for the changes.
- ❑ Prepare regular reports summarizing the status of the budget and comparing project progress and schedule.

### 7.7.2 Information Requirements

- ❑ To develop an elemental estimate, there are four general pieces of information required:
  - organizational mission
  - cost limitations
  - building size, site, and employee limitations (aging, injury, disease, disability)
  - occupancy requirements
- ❑ With this basic information, the next step is to establish ergonomic design parameters for the proposed building.

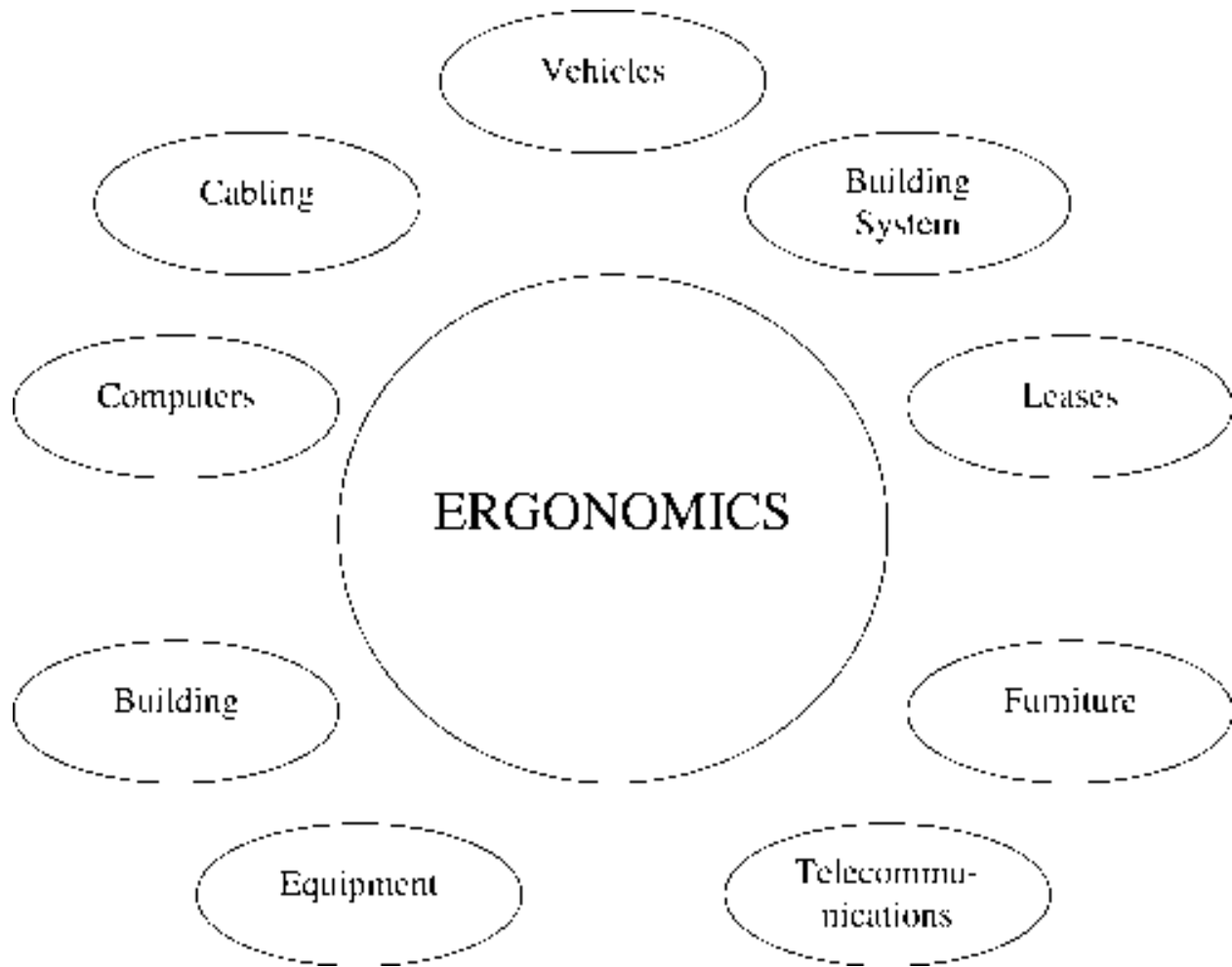

**Figure 7.1. Facility asset management as related to ergonomics.**

The following list shows a typical breakdown of ergonomic classifications for a detailed unit price estimate, and for an elemental estimate.

**Ergonomic Factors**

- |                      |                       |
|----------------------|-----------------------|
| accessibility        | equipment             |
| adaptability         | finishes              |
| air quality          | furnishings           |
| benchmarking         | housekeeping          |
| comfort              | image                 |
| communication        | instruments           |
| cost effectiveness   | interplant transfer   |
| density              | job safety analysis   |
| design               | landscaping           |
| division of space    | legibility of forms   |
| energy               | lighting              |
| engineering controls | maintenance, external |

maintenance, interior	robots
material handling	safety
material resource and conservation	security
nanotechnology	signage
noise	software
organizations	storage
passages	temperature
personal protective equipment	tools
pick patterns	training
planning	transport
quality	vendors
recycling	waste management
relocation	windows

### Unit Price Estimate

general requirements	doors and windows
site work	finishes
concrete	specialties
masonry	equipment
metals	furnishings
woods	special construction
plastics	mechanical systems
thermal protection	electrical systems
moisture protection	

### Elemental Estimate

foundations	conveying systems
subcontractors	mechanical systems
superstructures	electrical systems
exterior closure	conditions and profit
roofing	equipment
interior construction	site work

Elemental estimating enables an agronomist to stay within the budget by putting the preliminary estimate into the same form as the initial design. During the initial design process, the designer will be forced to make important decisions and trade-offs for each of the various building systems.

- Trade-offs
- Areas of trade-offs:
  - legal guidelines (ADA, EPA, OSHA)
  - price of each system

- appearance and quality
- site complications and restrictions
- owner’s special requirements in excess of code requirements
- thermal characteristics
- life cycle costs
- acoustical characteristics
- fireproofing characteristics

Elemental estimating can help considerably during the stage when these trade-offs are first being considered. If cost is a determining factor, as it often is, then systems estimating can quickly help the designer/ergonomist to determine which option is most cost effective.

## 7.8 Cost of Operations as It Relates to Ergonomics

- Direct costs to operate the building include ergonomic variable costs and a fixed basic cost:
  - maintenance and repairs
  - materials and labor
  - janitorial cleaning and supplies
  - utilities (electric, gas, water, heating oil)
  - landscaping, roads, common area
  - HVAC
  - maintenance worker tools
  - vehicles
  - service contracts

### 7.8.1 Project Cost

- The project cost is the cost required to design, demolish, and renovate workspace that has been previously completed as a capital improvement:
  - A/E fees
  - demolition cost
  - construction
  - cabling
  - electrical and lighting
  - HVAC
  - flooring
  - relocation

## 7.9 Factors That Relate Safety Management to Ergonomics

- Ergonomics:
  - vehicles
  - building systems
  - leases
  - furniture

- telecommunication
- equipment
- building
- computers
- cabling

### 7.9.1 Economic and Client Priority Considerations of Ergonomics

- Capital asset management process:
  - capacity
  - security
  - appearance
  - code violation
  - quality
  - environment
  - asset deterioration rate
  - marginal profitability
  - cost to defer
  - cost to delay
  - internal rate of return (IRR)
  - discounted cash flow
  - efficiency
  - mission support
  - effectiveness
  - risk reduction
  - safety and health

## Human Factors to Be Considered Related to Job Competencies

### Knowledge

- Methods of work
- Materials
- Machines and equipment
- Instruments and tools
- Organization
- Environment

### Psychology

- Concentration
- Fatigue
- Emotions

### Biomechanical

- Balance, coordination
- Full range of motion
- Sitting
- Standing
- Head
- Upper extremities
- Lower extremities

### Safety

- OSHA
- ANSI
- CDC
- GHS
- EPA

### Strength and Stamina

- Lift, carry, place, transfer
- Materials, objects, people
- Weight
- Height, width, length

### Sensory

- Vision
- Hearing
- Olfactory
- Skin
- Taste
- Speech

### Quality

- ISO
- Six Sigma

The ergonomic importance of density is to maintain a balance between employees and their stimulation from the physical environment. Environmental stimulation should not exceed the employee's capacity to scan and process information. Biomechanically, density of equipment, people, materials, or instruments should not impede direct access to each component. From a sensory perspective, density of stimuli should not overload the senses with excesses of competing noise, glare, smells, or images. Psychologically, density of materials, tools, equipment, or employees should not create a feeling of impingement on the personal space of individuals. Intellectually, density should not interfere with cognitive processes.

### 8.1 Ergonomic Design Benefits

- Improved safety
- Legal compliance

### 8.2 Consequences of Not Using Ergonomic Design

- Lost time
- Increased cost
- Legal citation
- Injury, illness
- Disease
- Fatality
- Lost quality

### 8.3 Design Considerations

- Density is a critical focus on the individual workplace and emerging workgroup configurations within organizational settings.
- Interior design should clearly demonstrate the advances in interior components and assemblies (ceilings, walls, floors, and furnishings), as well as their effective integration with:
  - structural systems
  - enclosure systems
  - mechanical systems
  - lighting systems
  - telecommunications and power systems

#### 8.3.1 Density Considerations

- Air quality
- Acoustic quality
- Amenities
- Connectivity
- Shared services
- Spatial quality
- Thermal quality

- Visual quality
- Workgroup concepts
- Vast open plan
- Cluster open plan
- Closed offices and shared closed offices
- Combi-offices
- Free address group address
- Caves and commons
- Box or universal workstations
- Workstations on wheels
- Campus and village, indoor-outdoor workplaces
- Home, road, and plane offices

#### 8.4 Improvement of Density and Spatial Quality in the Individual Workplace

- The question of density is directly related to the size of the workstations and corresponding amenities of work surfaces and storage.
- With the redistribution of work responsibilities and related telecommunications equipment, there is a critical need to shift away from the traditional allocation of space size, density, and furniture by rank to allocations by task or function.
  - The secretary’s workplace must often accommodate computers, typewriters, printers, fax machines, phones, and files.
  - A salesperson may be able to effectively function with a phone and a five-foot work surface, with files, books, and computer networking to complete his or her task.
- Density considerations include the range of tasks and effective work styles in the determination of workplace size and furniture options.

##### 8.4.1 Improving Workspace Design

- Improving the density and spatial quality of workstations is achieved by design. Density considerations include:
  - allowing for open systems furniture to evolve into closed offices through stackable panels
  - ceiling connections
  - three-dimensional space makers
- Innovative, high-efficiency storage to relieve the small footprint workstation and to respond to the dual office clutter created by electronics and paper. The paperless office is still years away, and electronics have drastically *increased* the paper produced.

##### 8.4.2 Connectivity in the Individual Workstation

- In the electronic workplace, one of the key concerns in density and design is adequate access to data, power, and voice connections.
- Several key factors contribute to this effective “connectivity”:
  - adequate central equipment space
  - adequate vertical and horizontal plenum space



**Figure 8.1. Stacking people to fit more in the space.  
Do they require ladder safety training?**

- adequate distributed or satellite closets for equipment and networking management
- effective network planning
- effective, modular outlet configurations
- desktop cable management
- ❑ Density is critical in designing effective workstations and workgroups with the spatial decisions of chairs, work surfaces, workspace enclosures, and cable management.
- ❑ There are four interrelated environmental quality agendas and their associated components and subsystems that must be integrated into the four workplace designs:
  - visual quality (lighting systems)
  - thermal quality (thermal conditioning)
  - air quality (ventilation systems)
  - acoustic quality (sound generating and canceling systems)
- ❑ The coordination of acoustic conditioning systems and the spatial defining systems is critical to ensure the necessary visual, thermal, air, and acoustic quality of the workplace.

## 8.5 Ergonomics and Density

- ❑ The General Services Administration (GSA) acts as the U.S. government's landlord, managing 254 million square feet of office space. In 1991, GSA issued a new temporary regulation (D-76) on space management. It includes new methods for calculating utilization rates. GSA is now developing new standards for measuring space leased by the federal government from building owners. These standards are also used for measuring space occupied by federal agencies. Hence, GSA is acting as both tenant and landlord. These new standards will include a method for obtaining parity between commercial measurement methods used in different markets and GSA-occupied space.
- ❑ The actual area available for exclusive tenant use is the governing factor for GSA space measurement.

### 8.5.1 Usable Area

- ❑ Usable area measures the actual occupiable area of a floor or building.
- ❑ The usable area on a multitenant floor can vary over the life of a building, as primary corridors change to accommodate tenant access, or as renovations affect building core and service areas.
- ❑ Usable area is a useful measurement for programming, planning, and allocating space.

### 8.5.2 Assignable Area

- ❑ Assignable area excludes secondary circulation space and measures the portion of a floor or building that can actually be used to house personnel, furniture, and equipment. Assignable areas are useful for detailing programming, planning, allocating, and layout of space.

### 8.5.3 Space Distribution System

- ❑ Space distribution system specifies the furnishings and finishes necessary for the above workflow, technology, and information systems, such as interior wall systems.
- ❑ Special items, like fireplaces or closets, may be important workplace amenities for an executive.
- ❑ Modular partitioning systems are conducive to maximum productivity and efficiency of space utilization. In the past, these were often incompatible with floor space.

### 8.5.4 Service Hubs and Shared Equipment

- ❑ Major innovations in office planning today are the service centers that provide access to:
  - copy machines
  - laser printers
  - new computer equipment
  - coffee and break room areas
- ❑ Shared equipment centers are critical to working efficiently today. They can also serve as social centers for the workplace and should be designed with this in mind.

ABSIC has put forth the concept of a relocatable service hub to serve a working neighborhood of 30–50 people.

- ❑ This service hub should be an elegant, open social space, central to all the workplaces, and should support a wide range of shared services and attributes:
  - coffee, microwave, refrigerator, sink, vending machines
  - color copiers, fax machines, laser printers (with extensive counter adjacent)
  - processors: file servers, communication copiers, digitizers, scanners
- ❑ Characteristics of the service hub:
  - dedicated air conditioning and exhaust systems
  - critical acoustic absorption (floors, ceilings, behind equipment)
  - generous storage area and supplies
  - high counters for stand-up discussions
  - adjacent seating and views for sit-down discussions
  - direct access to the outside

### 8.5.5 Conference Hubs

It is time for the conference room to come into the electronic age. Currently, most conference rooms up to 600 square feet have abysmal technical resolution, with slide projectors and screens and overheads and phones cluttering corners and conference tables, uncontrollable noise and heat releases, and unsafe power connections. Add to this the requirements of computer and video presentation, and teleconferencing and most conference rooms are seriously out of date.

The present conference room looks and performs like an electronic storage room.

- Develop a consolidated conference hub, one that is visually and physically compact, which enables the room to effectively use the slides, transparencies, and videos that are standard today.
- This compact center should be capable of accommodating employees and such audiovisual equipment as:
  - wide screen TV, VCR, projection TV, two video cameras
  - PC projector, PC, scribe position PC, controllers
  - dual slide projection, high-resolution overhead projection
  - electronic whiteboards, information display boards
  - fax, telephone, speakers (two-way audio)
  - data and power links
  - sight line optimization
  - dedicated air conditioning, exhaust systems
  - critical acoustic absorption
  - remote infrared controllers or laptops with radio bases
  - one dozen notebooks, radio-linked with split-screen displays for conferencing

For tomorrow, ABSIC envisions a conference facility where all inputs will become digital for projection within and transmission to a network of conference centers. In the university setting, this capacity would enable an outstanding faculty member to teach a class simultaneously at many universities, allowing students to receive the best and broadest in course offerings through multicampus teleconferencing.

## Human Factors to Be Considered Related to Job Competencies

### Knowledge

- Methods of work
- Materials
- Machines and equipment
- Instruments and tools
- Organization
- Environment

### Psychology

- Concentration
- Fatigue
- Emotions

### Biomechanical

- Balance, coordination
- Full range of motion
- Sitting
- Standing
- Head
- Upper extremities
- Lower extremities

### Safety

- OSHA
- ANSI
- CDC
- GHS
- EPA

### Strength and Stamina

- Lift, carry, place, transfer
- Materials, objects, people
- Weight
- Height, width, length

### Sensory

- Vision
- Hearing
- Olfactory
- Skin
- Taste
- Speech

### Quality

- ISO
- Six Sigma

**D**esign is critical to ergonomics as a systematic planned approach to using all the relevant characteristics of employees (biomechanics, senses, psychology, intellect) to create the optimum interface between these employees and man-made objects, operational facilities, and working environments. Ergonomic design should enhance productivity and efficiency by reducing stresses and fatigue so that employees can work productively and safely, and produce high-quality work. In ergonomics, design should strive to understand and maintain the unique functional capacities of people in the workplace environment.

Design should consider people with respect to methods of work, materials used, machines, equipment, tools, and instruments as guides.

Design should consider people as using their bodies biomechanically, sensorially, psychologically, and intellectually.

## 9.1 Ergonomic Design Benefits

- Improved safety
- Increased productivity



**Figure 9.1.** Design of space considers biomechanics and sensory stressors.

## 9.2 Consequences of Not Using Ergonomic Design

- Lost time
- Increased cost
- Legal citation
- Lost quality

## 9.3 Ergonomic Design and Amenity Services

- Support and amenities in facilities are generally shared by all workers. They tend not to be assigned to a specific end-user organization or department. Instead, they are centrally managed for the benefit of all occupants. Each case involves a consistent set of service functions, which are grouped into twelve categories. These categories are the basis of planning guides.

### 9.3.1 Employee Services

- Transportation and parking
- Public and visitor services
- Meeting and assembly services
- Technical information services
- Employee and convenience services
- Food services
- Circulation and interaction facilities

### 9.3.2 Facility Operations

- Information and communication systems
- Office and lab support services
- Material handling services
- Security and safety services
- Building and site services

### 9.3.3 Factors to Be Evaluated

- The following factors must be evaluated within the guidelines defined by the American National Standard Organization (ANSI/ASQC Q91-1987, Q92-1987, Q93-1987). The ANSI standards are technology-equivalent to International Standards ISO 9001, 9002, and 9003. World Class Manufacturing, American National Standards for work stations (100/1988), and laws and guidelines from the Occupational Safety and Health Act should also be incorporated.
  - job task
  - expected productivity rates
  - stressors
  - elimination of employee musculoskeletal stressors
  - measurement of working area
  - review of employees' use of shared equipment

- assessment of:
  - accessible lighting
  - adaptability maintenance (external)
  - air quality maintenance (internal)
  - benchmarking image
  - comfort of passages
  - communication planning
  - cost-effectiveness relocation
  - density resource conservation
  - design safety
  - division of space, security, energy, and signage
  - equipment software
  - finishes furnishings
  - storage temperature
  - tools noise
  - instruments training
  - windows landscaping
- design of the employees' work stations, support equipment, and radius of work areas
- evaluation of seating
- evaluation of support equipment
- review of total physical plant as each worker interacts with the work environment
- Design of work areas, surfaces, and tools where technologies must be integrated into other key design factors that satisfy the expectations of both the supervisor and employee.

### 9.3.4 What Employers Want to Know

Employers want to know if the work site design makes the best use of:

- Esthetics and image
- Ease of maintenance
- Function and fitness
- Lowered first costs and life cycle costs
- Responsiveness of a status-marking system
- Bulk purchase agreements or existing inventory

### 9.3.5 Satisfying Criteria While Meeting Corporate Standards, Laws, and Guidelines

Employers want to know if the rooms satisfy criteria while meeting corporate standards, laws, and guidelines of:

- Appearance
- Comfort
- Ease of communication
- Ease of participation
- Flexibility

- Layout
- Occupancy level
- Relocation frequency
- Safety (rules posted)
  - equipment grounded
  - no extension cords
  - safe smoking areas
  - rugs secure

### 9.3.6 What Both Employees and Employers Want to Know

Both employees and employers want to know if the room provides the appropriate atmosphere by:

- Increasing opportunities for individual choice
- Encouraging independence
- Compensating for changes in perception and sensory acuity
- Decreasing unnecessary mobility
- Encouraging social interaction
- Stimulating participation in activities offered
- Reducing conflict and distraction
- Providing a safe environment
- Making activities accessible
- Improving employer and employee image
- Allowing for growth and change in individuals

### 9.3.7 Design Recommendations

- Taking into consideration the environmental design and specific individual design factors and work environments, work stations and work technologies should be uniquely designed for individual capabilities.
- These recommendations illustrate the range of customized options that increase productivity while reducing stress and fatigue.

### 9.3.8 Quality Check Considerations

- Are tasks performed more efficiently?
- Are productivity rates maintained or exceeded?
- Are stressors diminished?
- Have muscular stressors been eliminated?
- Have injuries and symptoms been reduced?
- Is the physical relationship with equipment well integrated for the employee?
- Are accessories within easy reach?
- Are there resources for performing the tasks?
- Has the intensity of concentration required been reduced?
- Is the environment totally accessible?
- Have the individual's limitations been mitigated by well-integrated interventions?
- What effect have the interventions had on other employees and supervisors?

## Human Factors to Be Considered Related to Job Competencies

### Knowledge

- Methods of work
- Materials
- Machines and equipment
- Instruments and tools
- Organization
- Environment

### Psychology

- Concentration
- Fatigue
- Emotions

### Biomechanical

- Balance, coordination
- Full range of motion
- Sitting
- Standing
- Head
- Upper extremities
- Lower extremities

### Safety

- OSHA
- ANSI
- CDC
- GHS
- EPA

### Strength and Stamina

- Lift, carry, place, transfer
- Materials, objects, people
- Weight
- Height, width, length

### Sensory

- Vision
- Hearing
- Olfactory
- Skin
- Taste
- Speech

### Quality

- ISO
- Six Sigma

The ergonomic importance of the division of space is to provide for the broad-based fulfillment of criteria that are necessary for work performance. Division of space biomechanically provides an opportunity for both interaction and privacy within a primary work area. Secondary division of space issues to consider are mobility, convenience, safety, and security of employees when accessing areas for resources, food, or personal hygiene. Psychologically, the division of space is relevant to an employee's feeling of aesthetics, values, and security. Intellectually, division of space should account for a necessary size in which tasks can be accomplished without an undue burden of resource support (heat, water) and in proximity to all necessary resources. Division of space should create a natural flow for employees from private workspace to shared areas.

### 10.1 Ergonomic Design Benefits

- Improved safety
- Legal compliance

### 10.2 Consequences of Not Using Ergonomic Design

- Lost time
- Increased cost
- Legal citation
- Lost quality

Aspects of work areas and work stations to consider include workspace layout, work surfaces, standing and walking surfaces, seating, storage, work fixtures, materials handling/movement and work environment. Workspace layout and arrangement should allow:

- Adjustability to fit each worker's size within an appropriate population percentile.
- Worker to maintain neutral posture and avoid awkward or extended reaches and jerky movements while performing the tasks.
- A variety of working positions to avoid static postures.
- Full range of motion and adequate legroom.
- Adequate space for and access to all necessary tools and equipment.
- Frequently used work items within easy arm's reach.
- Unobscured line of sight.

### 10.3 Workplace Use

- Workplaces are used to accomplish work and social leisure activities. This includes multiple settings within the "organizational complex" of facilities as well as remote suburban locations and at-home work.

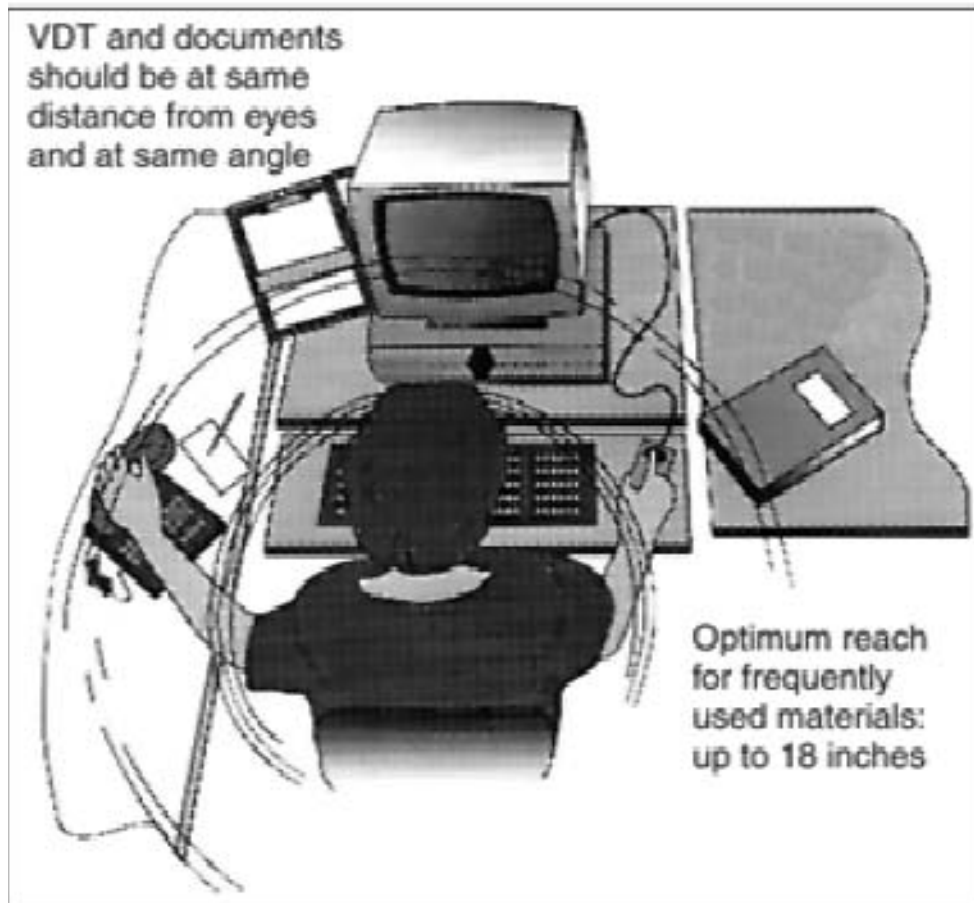

Figure 10.1. Division of space: VDT work surface and range of motion.

### 10.3.1 Working at Many Locations

- ❑ The goal of planning ergonomics is to acknowledge that employees can work at many locations within a set of facilities (e.g., plant, laboratory, corporate offices) as well as off-site and at-home offices.
- ❑ Providing workplaces at a variety of these locations is part of safety management. The workplaces are not always traditional.
- ❑ Nontraditional workplaces include:
  - enclosed workrooms shared by many people at different times
  - quiet lounges with personal carts or caddies for storage and laptop computers
  - suites of offices in suburban shopping centers used as satellite locations

- ❑ Home offices are being utilized by 20% of working professionals.
- ❑ The at-home worker can be employed at any professional level within the organization. These workers are not necessarily a remote workforce, nor are they full-time, at-home workers.
- ❑ The amount of at-home work is individually negotiated. Employees can stay networked and integrated into ongoing business.
- ❑ All management and safety prerogatives should be maintained at all work locations.

### 10.3.2 Changing Office Approaches

- ❑ Companies using adaptability of worksites can often attract non-traditional workers. The idea behind all these “officing alternatives” is not necessarily to save space or reduce usable square feet per person; this is often a by-product.
- ❑ Ergonomics helps to match the workplace to the people and the corporation to maintain productivity and efficiency.

## 10.4 Ergonomics of the Shared Office

The world’s business environment is changing, as are individual workers and the workplace. The operational issues in these future places of work are many. The following are a few examples that apply to different officing approaches.

- ❑ The goal of ergonomic adaptability is to provide more space and facility per person, while getting more “round the clock shifts in peak times utility” from each space.
- ❑ The goal is to reduce the amount of space that is unoccupied for significant periods of time, analyzing both the amount of space used and frequency of use to determine space needs.
- ❑ Design spaces with more immediate adjustability by the individual (desk height, seat, etc.) and more choice locations (e.g., conference room/office, lounge area/mobile office).
- ❑ Telephone systems, room reservation, and location systems are critical to successful shared and just-in-time officing formats.
- ❑ Shared space is used by employees who spend time out of the office (e.g., salespeople, field engineers, auditors, consultants, project managers).
- ❑ Ergonomically designed shared offices result in space savings and annual cost savings. Cost savings in salaries for housekeeping and maintenance, when aggregated to include all appropriate maintenance savings for a company of 1,000 employees, could be \$1 million in leased space.

### 10.4.1 Non-Territorial Spaces

- ❑ A group of employees share a single work area with no defined personal workspace.
- ❑ All employees share files, library or resource areas, lab space, large worktables, and quiet spaces.
- ❑ Ergonomic adaptability encourages group and team interaction, and the “fortuitous encounter.”

- ❑ Ergonomics encourages increased employee interaction, which shortens development cycles and improves productivity and work quality.
- ❑ Non-territorial spaces can be used for development engineers, temporary task forces, multidisciplinary teams, and temporary workers.

#### 10.4.2 Free Address

- ❑ Free address is a term used primarily in Japan. The goal, depending on the type of employee facilitated, is the same as the non-territorial space, shared spaces, and just-in-time office.

#### 10.4.3 Home Base/Cave and Commons

- ❑ Each employee has a small dedicated office, and employees share a variety of open group spaces (large worktables, lounge areas, terminals, media space, etc.) with the work team.
- ❑ The goal is similar to the non-territorial space, with the exception that individuals have a private space of their own.

#### 10.4.4 Telecommuting

- ❑ Employees work at home, in the field at a client site, and at a remote corporate facility, as well as in the headquarters' offices.
- ❑ Telecommuting allows people the flexibility of working at home or at a remote office while also having some base of operation at corporate facilities.
- ❑ Typically the telecommuter's workspace is small or shared. The goal is to put workplaces at the most convenient location to the worker and his or her work.
- ❑ The company may supply equipment and furnishings for the home or remote office setting.

#### 10.4.5 Media Space

- ❑ Media spaces are individual and/or team spaces that have both video and audio recording and receiving capabilities. The theory is that "you don't have to be there to be there."
- ❑ The goal of using media space is to overcome both time and space limitations. —primarily used by development engineers and designers to keep in constant contact with remote design and engineering collaborators and production facilities —will ultimately expand to many other types of workers
- ❑ The media space is a success when a larger number of team members have access to more information, more often. Projects are completed faster with fewer errors.

#### 10.4.6 Operational Issues on Non-Traditional Spaces

The idea of all these officing alternatives is not necessarily to save space or reduce usable square feet per person. This is often a by-product. Matching the individual to method of work in places acknowledges that corporations are made up of people working. The world business environment is changing, as are individual workers and their workplaces. The operational issues in these future places of work are many.

## 10.5 Ergonomic Adaptability at Work

- ❑ Goals and measurements require clear goal setting to:
  - save space
  - increase access to more space
  - enhance individual flexibility of work hours and location
  - increase group interaction
  - decrease office reconstruction time
  - increase user satisfaction
  - increase individual or group productivity
  - increase space utilization, etc.
- ❑ Requires both quantitative and qualitative measurement of results
- ❑ Requires increased participation by users to work out administrative details of:
  - shared equipment
  - files
  - space
  - overlapping work hours
  - secretarial support
  - check-in/check-out process
  - additional support services
  - actual job design
- ❑ Facility requirements:
  - increasingly adjustable furniture and equipment by the individual
  - increased meeting and group workroom space
  - opportunities for selective and absolute privacy
  - different dispersal, mix, and design of individually occupied space
  - space to be analyzed and distributed in terms of times and frequency of use as well as amount of space needed per person
- ❑ Technology requirements:
  - increased use of equipment (e.g., mobile phones, terminals, videos, recorders)
  - increased variety of work surface, wires, and amount of space needed for equipment
  - increase in the number of and flexibility in operations and distribution of data lines and connectors, telephones, faxes, printers, mobile phones, etc.
- ❑ Operations requirements:
  - increased housekeeping staff for shared or just-in-time space
  - individual and group job design
  - administrative office procedures that include check-in and check-out, location aids, etc.
  - inventory of equipment and furnishings in more locations, often in smaller numbers
  - managing space at often multiple small, leased sites
- ❑ The changing workplace is being used as a tool for management to:
  - accommodate individual choice
  - reward individual initiative
  - accommodate both the amount of space needed and the time space is needed

- support increasingly collaborative work
- adapt to a mobile workforce and workplace
- be a resource that must be more fiscally responsive

### 10.5.1 Changing Work Styles

- ❑ The use of traditional work settings—one person, one space, eight hours a day, in centralized corporate spaces—will undoubtedly change over the next 10 to 15 years.
- ❑ Not all employees will be working in redefined places of work. However, even if 10% of Xerox’s employees at roughly 100 sites needed a non-traditional work setting, 11,400 employees would be affected.
- ❑ Technology is dramatically changing work styles. These changes allow the shift from city central and suburban lifestyles to sub-suburban and remote settings.
- ❑ Labor shortages could actually increase productivity by forcing corporations to deploy future and existing labor in more creative ways.
  - Increased numbers of women, aging workers, and more educated workers are changing the workforce profile, and with it, worker demands.
  - The need to interact “personally” with more people, more frequently, both in the immediate neighborhood and the world community, over a 24-hour world workday, makes change a necessity.

### 10.6 Adaptability and Productivity

- ❑ Those of us who perform safety-engineering work for corporations and their employees must be aware of how work is changing and of the implications of how we ergonomically forecast, design, manage, and deliver work settings for the future.
- ❑ Productivity, at an ever-increasing rate, and adaptability, at an ever-expanding definition, are watchwords for the corporation, and ergonomic goals for safety management.

## Human Factors to Be Considered Related to Job Competencies

### Knowledge

- Methods of work
- Materials
- Machines and equipment
- Instruments and tools
- Organization
- Environment

### Psychology

- Concentration
- Fatigue
- Emotions

### Biomechanical

- Balance, coordination
- Full range of motion
- Sitting
- Standing
- Head
- Upper extremities
- Lower extremities

### Safety

- OSHA
- ANSI
- CDC
- GHS
- EPA

### Strength and Stamina

- Lift, carry, place, transfer
- Materials, objects, people
- Weight
- Height, width, length

### Sensory

- Vision
- Hearing
- Olfactory
- Skin
- Taste
- Speech

### Quality

- ISO
- Six Sigma

The ergonomic importance of energy is to consider the interface between human actions and work environments in which the objective is to obtain the optimum level of productive activity. The inappropriate use of energy occurs when human energy is wasted or when the use of energy leads to fatigue and exhaustion, causing occupational illness or injury. The use of human energy at the optimum level is ergonomically acceptable only when the intensity of the effort occurs without stress or strain.

Biomechanically, energy should be expended that does not overload the body to the point of damage to the muscles, tendons, or ligaments. Static and dynamic load to the muscles, tendons, and ligaments should be considered, particularly in combinations of force, awkward postures, repetition, and duration. Physiologically, energy should only be expended to the point that the body experiences a small increase in respiratory rate, temperature, blood pressure, heart rate, sinus arrhythmia, and pulse volume. Equally important is the avoidance of pulse deficit and extremely low temperatures. The body should not be stressed or strained by extreme sensory stimulation created by noise, heat, cold, vibration, or brightness.

Psychologically, energy should be expended to maintain vigilance to the intellectual requirements of job tasks. Therefore, extremes of boredom and intellectual overload should be considered. For example, watching video screens for long periods of time with no interaction (e.g., security guards) is extremely boring. In contrast, watching video screens that require constant vigilance and tweaking to avoid machine failure is too intense (e.g., job start-ups on new equipment). Human energy should be conserved in the same manner as resourced energy (electricity, water, and fuel).

### 11.1 Ergonomic Design Benefits

- Improved safety
- Improved use of energy
- Cost reduction
- Legal compliance

### 11.2 Consequences of Not Using Ergonomic Design

- Increased cost

### 11.3 Energy/Resource Management

- Telecommunications planning plays a significant part in managing the nation's energy and resources.
- Misuse of telecommunications hardware contributes to a wide range of problems in the modern office and results in unnecessary energy usage, including:
  - excessive plug loads, even when idle
  - excessive ambient light levels
  - ineffective task lighting
  - inadequate daylight utilization
  - overheating and a demand for additional cooling
  - unmanageable air distribution patterns

- excessive peak loads
- inadequate submetering
- the serious problem of equipment disposal, as it is rapidly exchanged for something newer and better

## 11.4 Legislative Milestones

- ❑ In 1975, the Energy Policy and Conservation Act (EPCA) was enacted and addressed energy conservation issues in the federal government. It included energy management goals for the operation and procurement of buildings and also required that the federal automotive fleet meet or exceed the corporate average fuel economy (CAFE) standards.
- ❑ In 1977, Executive Order (EO) 12003, issued by the president, established a goal to reduce energy consumption in federal buildings by 20% (on a per square foot basis) by the year 1985, as compared to 1975. This EO also established life cycle standards for government decision-makers.
- ❑ In 1978, the National Energy Conservation Policy Act (NECPA) further extended the management goals first promoted by EPCA and EO 12003.
- ❑ In 1982, EO 12375 amended EO 11912 and EO 12003 and relaxed the requirements for the federal fleet to meet the CAFE standards.
- ❑ In 1988, the Federal Energy Management Improvement Act (FEMIA) established a goal to reduce energy consumption in federal buildings by 10% by 1995, as compared to 1985.
- ❑ In 1991, EO 12759 further mandated energy consumption reduction goals for buildings and industrial facilities by 20% by the year 2000, as compared to 1985.

### 11.4.1 Past Accomplishments

- ❑ Between 1973 and 1975, the General Services Administration (GSA) reduced energy consumption by approximately 25% by implementing low-cost/no-cost operations and maintenance improvement.
- ❑ Between 1975 and 1985, GSA further reduced its energy consumption by more than 20% by continuing the management practices started in 1973 and by implementing energy conservation improvements to its buildings.
- ❑ Petroleum conservation programs resulted in reducing GSA petroleum use by 75% between 1973 and 1985.
- ❑ New goals established in the Federal Energy Management Improvement Act of 1988 and EO 12759 set the course for federal agencies through the end of this century. The responsibility for implementing these goals falls under each individual agency, with the understanding that each knows the intricacies of its mission and can best incorporate this knowledge into its energy conservation plan.

## 11.5 Overutilization

- ❑ Many American industries utilize twice as much energy to produce the same product as their foreign competitors do. The effort to overcome this imbalance of energy over consumption is an important step toward long-term economic growth.

## 11.6 Subtitle E: State and Local Assistance

Subtitle E assists state energy conservation programs by providing million-dollar grants to state revolving funds to be used to finance energy efficiency improvements in state and local government buildings. These grants are to be administered by the secretary of energy. To be eligible, states must meet three criteria:

- ❑ Residential and commercial building codes for the state and the majority of local governmental units must meet or exceed CABO and ASHRAE codes, as appropriate.
- ❑ The state must have an established financing program, including a revolving fund.
- ❑ The state must have obtained funds from non-federal sources such as oil-overcharge funds, utility companies (including rebates), and local appropriations, in an amount three times greater than that provided by the secretary.

## 11.7 Subtitle F: Federal Agency Energy Management

- ❑ Subtitle F mandates wide-range federal energy program requirements, some of which federal agencies were already complying with from EO 12759.
- ❑ The Energy Policy Act legally established the same energy consumption reduction goals that were established in EO 12759.
- ❑ The Federal Energy Management Improvement Act of 1988 had established a 10% reduction goal between fiscal years 1985 and 1995. President Bush expanded that goal in April of 1992, with EO 12759, to a 20% reduction between fiscal years 1985 and 2000.
- ❑ This subtitle also established the goal of instituting all energy and water conservation measures with a 10-year payback or less by the year 2005.
  - This is the first time since the 1970s that water conservation has come to the forefront.
  - The 19-year payback portion of the goal is very difficult for federal energy managers to get a handle on or to get serious about.
  - As the act was being drafted, GSA representatives commented that it would be confusing to have two different goals.
  - They further said that with technologies changing so rapidly in the energy conservation arena, new fast-payback technologies developed late in the goal period would certainly ensure that no agency would be able to meet this goal.
  - It would also require expensive and continual energy audits, which the federal budget clearly would not fund, in order to have some measures of whether or not the goal was met.
- ❑ Title I: Energy Efficiency
  - Subtitle A: Buildings
  - Subtitle B: Utilities
  - Subtitle C: Appliances and equipment
- ❑ Energy efficiency standards
  - Subtitle D: Industrial
  - Subtitle E: State and local assistance
  - Subtitle F: Federal agency energy management
  - Subtitle G: Miscellaneous

## Human Factors to Be Considered Related to Job Competencies

### Knowledge

- Methods of work
- Materials
- Machines and equipment
- Instruments and tools
- Organization
- Environment

### Psychology

- Concentration
- Fatigue
- Emotions

### Biomechanical

- Balance, coordination
- Full range of motion
- Sitting
- Standing
- Head
- Upper extremities
- Lower extremities

### Safety

- OSHA
- ANSI
- CDC
- GHS
- EPA

### Strength and Stamina

- Lift, carry, place, transfer
- Materials, objects, people
- Weight
- Height, width, length

### Sensory

- Vision
- Hearing
- Olfactory
- Skin
- Taste
- Speech

### Quality

- ISO
- Six Sigma

The importance of engineering controls in ergonomics is to create the optimum support to static and dynamic work methods. Engineering controls involve making changes to workstations or tools or equipment used on the job, or changing the way a job is done to avoid work-related musculoskeletal hazards. These controls are preferred over all others because they make permanent changes that eliminate hazards at the identified source. By eliminating the sources of ergonomic hazards in the workplace and preventing musculoskeletal disorders (MSDs), engineering controls can be the most cost-effective solutions for your organization to implement.

Aspects of workstations you can change with engineering controls include workspace layout, work surfaces, standing and walking surfaces, seating, storage, work fixtures, materials handling/movement, and work environment. Workspace layout and arrangement should allow:

- Adjustability to fit each worker's size within an appropriate population percentile.
- Worker to maintain neutral posture and avoid awkward or extended reaches and jerky movements while performing the tasks.
- A variety of working positions to avoid static postures.
- Full range of motion and adequate legroom.
- Adequate space for and access to all necessary tools and equipment.
- Frequently used work items within easy arm's reach.
- Unobstructed line of sight.

Engineering controls can be one intervention or a set of controls that span solutions. Common controls begin with reviewing your job safety analysis and taking action in one of five ways that reduce the risk factors for tasks:

- Elimination of a hazardous task and associated risk factors
  - force
  - awkward posture
  - repetition
  - duration
  - vibration stress
  - temperature extremes
- Accommodation that includes a change in schedule or task sequence
- Mechanization to aid a process, as in using a dolly vs. carrying a load
- Automation to move parts or people
- Robots to complete a task sequence with or without worker involvement

Engineering controls include workstation design, work methods design, tool and equipment design, controls and displays, connectors, fasteners and valves, and product design.

## 12.1 Ergonomic Design Benefits

- Improved productivity
- Improved safety

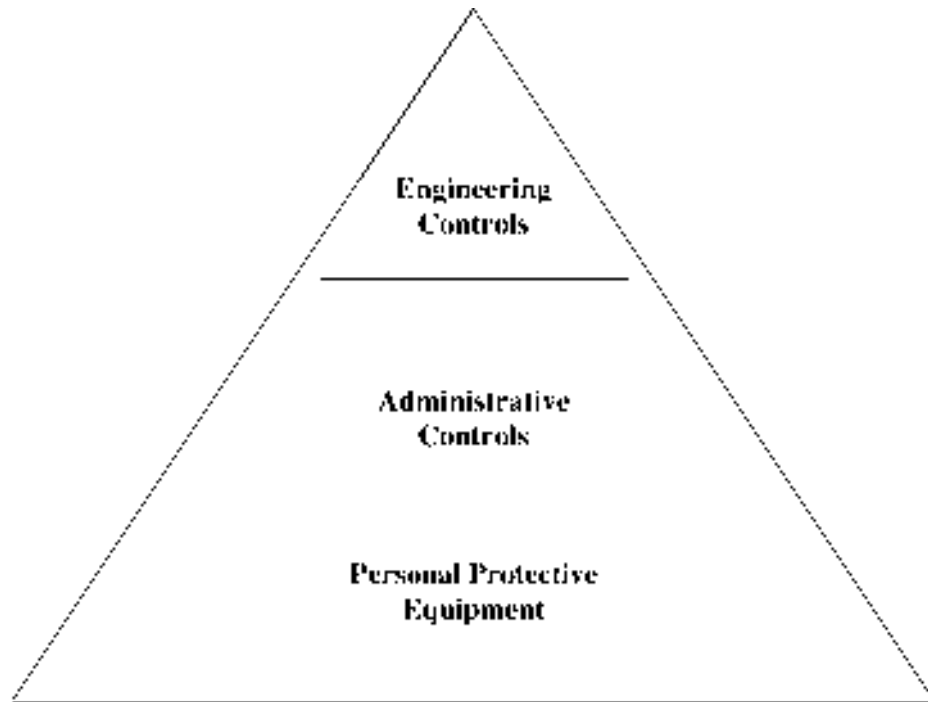

**Figure 12.1. Engineering controls have supervision and accommodation integration.**

- Improved quality
- Legal compliance

## **12.2 Consequences of Not Using Ergonomic Design**

- Lost time of workers
- Increased cost of training or rework
- Legal citation
- Injury, illness
- Disease
- Fatality
- Lost quality

## **12.3 Risk Factors Reduced by the Use of Engineering Controls Guidelines**

### **12.3.1 Excessive Force**

Workers must use excessive force when objects are difficult to grasp or control, equipment and tools are poorly maintained, or tasks require awkward postures. To eliminate the use of excessive force:

- Improve friction on slippery objects.
- Use mechanically assisted devices for awkward lifts.
- Choose tools that fit the dominant hand. Be mindful that some of the population is left-handed.
- Keep equipment properly maintained to prevent jamming and sticking.
- Provide adequate workroom to perform tasks.

### 12.3.2 Static or Dynamic Awkward Postures

Prolonged static or awkward postures can rapidly cause fatigue. Work should be done so neutral postures are maintained, stoops and reaches are avoided, and time working overhead is minimized. For example, shared workstations should be easily adjustable so the screen and keyboard can be at the proper level. These aspects should be taken into account to prevent discomfort and/or injury.

- Neutral posture at the keyboard and mouse: arms comfortably at the sides, elbows bent at approximately 90 degrees, forearms parallel to the floor, knees slightly below hips, and wrists straight.
- Dynamic tasks should be organized so that workers at a conveyor belt do not have to lean over the belt.

### 12.3.3 Repetitive-Motion Tasks

Tasks involving repetitive motion are major contributors to cumulative-trauma disorders. You can minimize repetition by:

- Using automation, such as in stapling, sorting, labeling, or filling operations.
- Changing the job to include tasks that do not use the same muscle groups.

### 12.3.4 Duration

The capacity of workers should be considered in establishing production goals. Increased work rates, excessive overtime, and incentive programs for piecework can cause fatigue, increasing the chance for injury.

### 12.3.5 Vibration Stress

Nerves, tendons, and blood vessels can be damaged by exposure to excessive vibration from equipment and tools. Some tools require excessive force to control, such as jackhammers. Equipment and tools should be dampened to prevent stress to the body. For example, grinding tools that have high vibration can be dampened with frames that stabilize the tool as it grinds materials to be shaped into products. In this case, rather than leveraging the body and hands to maintain the tool's position, the frame holds the tool against the material with the right tolerance.

### 12.3.6 Temperature Extremes

- Isolate equipment or operations that produce excessive heat or cold.
- Keep wind chill factors to a minimum.
- Isolate hands and feet from cold.
- Reduce whole-body exposures, particularly the head, to temperature extremes while riding or standing near equipment.
- Isolate workers from excessive heat; provide adequate cooling and ventilation.

### 12.3.7 Vibration Combined with Temperature Extremes

- Isolate equipment vibration and cold stress with insulated anti-vibration gloves.
- Reduce whole-body exposures to vibration of tools held against the body during cold, wet, or heat stress conditions.

## 12.4 Final Note

- Engineering controls are the integration of productivity, safety, and quality. The more workers understand the competency requirements of their jobs and supervisors have the strategy to reinforce safe actions, the better.

## Human Factors to Be Considered Related to Job Competencies

### Knowledge

- Methods of work
- Materials
- Machines and equipment
- Instruments and tools
- Organization
- Environment

### Psychology

- Concentration
- Fatigue
- Emotions

### Biomechanical

- Balance, coordination
- Full range of motion
- Sitting
- Standing
- Head
- Upper extremities
- Lower extremities

### Safety

- OSHA
- ANSI
- CDC
- GHS
- EPA

### Strength and Stamina

- Lift, carry, place, transfer
- Materials, objects, people
- Weight
- Height, width, length

### Sensory

- Vision
- Hearing
- Olfactory
- Skin
- Taste
- Speech

### Quality

- ISO
- Six Sigma

The ergonomic importance of equipment and controls is a critical preemptive factor in preventing occupational illness and injury. Equipment and controls are an extension of the human capability and should be designed to accomplish tasks while preventing stress and strain to the worker. Equipment should perform the work more efficiently than the worker unassisted. Controls for equipment should require a clear psychomotor action by a worker. Individual equipment differences should be considered based on the range of equipment users. Equipment controls and displays should be located based on their importance, frequency, and sequence of use. Indicators need to take into consideration the height, reach, and visual and auditory acuity of workers. Controls and displays need to be visible and accessible while in use and easy to operate in relation to equipment functions. Spacing of control buttons should be adequate to accommodate gloves or other protective equipment.

Typically lacking in the evaluation of equipment/controls ergonomics is an anthropomorphic database on real workers in real work settings using equipment and controls efficiently. Establishing a database is important to purchasing and redesign decisions.

### 13.1 Ergonomic Design Benefits

- Improved safety
- Legal compliance

### 13.2 Consequences of Not Using Ergonomic Design

- Lost time
- Increased cost
- System failures
- Injury, illness
- Disease
- Fatality
- Lost quality

### 13.3 Controls

Controls are devices (switches, dials, connectors, valves) that transmit control information to some mechanism or system. They activate, set to discrete positions, manage flow, and enter data. Controls relate to functions. Control components should be located to allow visible readings and neutral postures of access during work. The following can help reduce risks:

- Switches should flip in two directions for on and off without a decision on degree.
- Dials should be easy to read and turn.
- Connectors should be labeled and set up to make connection easy and prevent cross-connection. Quick-release connectors and fasteners should require few turns with little force.
- Valves should be positioned to allow easy access to turn and lock down.

- ❑ Consider human factor aspects in “controlling” equipment. In some cases, this requires correct and rapid identification of a control to maintain safety, such as the foot pedal to operate an automobile’s braking system.
- ❑ Controls should have the shape, texture, size, location, color, sequence, operational label, and method to be understood, so they can be accurately used with speed.

### 13.4 Coding Controls

- ❑ Shape and texture desirable features
  - useful where illumination is low or where device may be identified and operated by feel, without use of vision
  - can supplement visual identification
  - useful in standardizing controls for identification purposes
- ❑ Shape and texture undesirable features
  - limitation in number of controls that can be identified (fewer for texture than for shape)
  - use of gloves reduces human discrimination
- ❑ Location desirable features
  - useful where illumination is low or where device may be identified and operated by feel, without use of vision
  - can supplement visual identification
  - useful in standardizing controls for identification purposes
- ❑ Location undesirable features
  - limitation in number of controls that can be identified
  - may increase space requirements

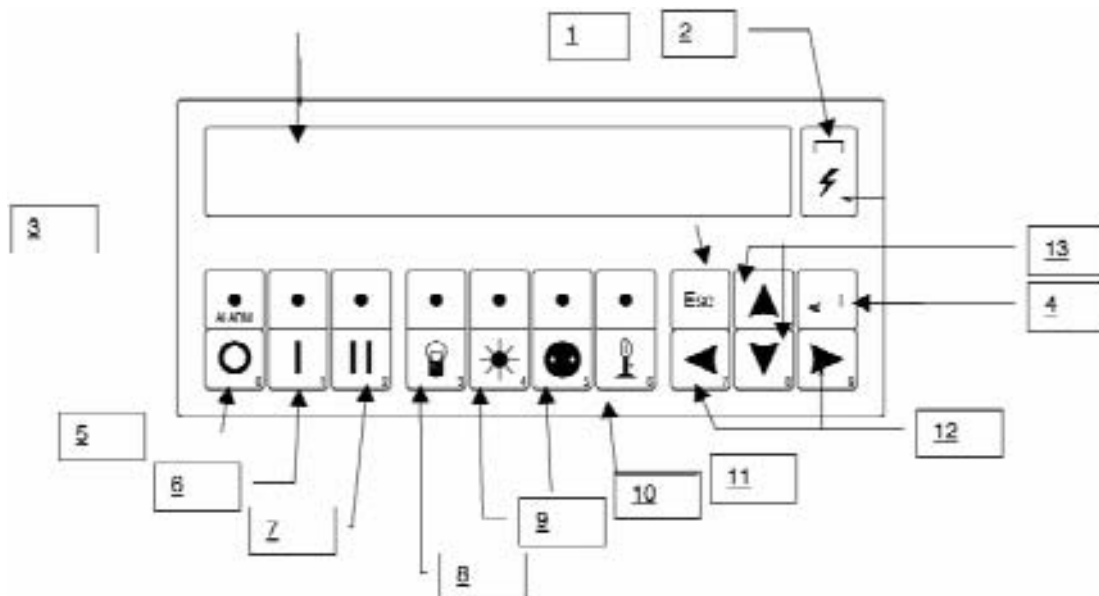

Figure 13.1. Equipment controls with symbols.

- identification may be uncertain (may be desirable to combine with other coding scheme)
- ❑ Color desirable features
  - useful for visual identification
  - useful for standardizing controls for identification purposes
  - moderate number of coding categories possible
- ❑ Color undesirable features
  - must be viewed directly (but can be combined with some other coding method, such as shape)
  - cannot be used under poor illumination
  - requires people who have adequate color vision
- ❑ Labels desirable features
  - large number can be identified
  - does not require much learning
- ❑ Labels undesirable features
  - must be viewed directly
  - cannot be used under poor illumination
  - may take additional space
- ❑ Operational method desirable features
  - usually cannot be used incorrectly (control usually is operable in only one way)
  - can capitalize on compatible relationships (but not necessarily)
- ❑ Operational method undesirable features
  - must be tried before knowing if correct control has been selected
  - specific design might have to incorporate incompatible relationships

## 13.5 Visual Displays on Equipment Criteria

### 13.5.1 Quantitative Scales

- ❑ Digital or open-window is preferable if values remain long enough to read.
- ❑ Fixed-scale, moving-pointer designs are usually preferable to moving-scale, fixed-pointer designs.
- ❑ For long scales, moving scale with tape on spools behind panel or a counter plus circular scale has practical advantage over fixed scale.
- ❑ For values subject to continuous change, display all (or most) of range used (as with circular or horizontal scale).
- ❑ If two or more items of related information are to be presented, consider integrated display.
- ❑ Smallest scale unit to be read should be represented on scale by about 0.05 inches or more.
- ❑ Preferably use marker for each scale unit, unless scale has to be very small.
- ❑ Use conventional progression system of 1, 2, 3, 4, etc., unless there is reason to do otherwise, with major markers at 0, 10, 20, etc.
- ❑ Preferable use is a fixed scale with moving pointer (to show trends).
- ❑ For groups, use circular scales, and arrange null positions systematically for ease of visual scanning, as at 9 o'clock or 12 o'clock position.
- ❑ Preferably use extended pointers and extended lines between scales.

### 13.5.2 Status Indicators

- ❑ If basic data represent discrete, independent categories, or if basically quantitative data are always used in terms of such categories, use display that represents each.

### 13.5.3 Signals and Warning Lights

- ❑ Minimum size used must be consistent with luminance and exposure time.
- ❑ Red light is more visible with low signal-to-background contrast.
- ❑ Flash rate for flashing lights of 1 to 10 per second presumably can be detected by most employees.

### 13.5.4 Representational Displays

- ❑ Moving element (such as an aircraft) should be depicted against a fixed background (as the horizon).
- ❑ Graphic displays that depict trends are read better if they are formed with lines rather than with bars.
- ❑ Pursuit displays usually are easier for people to use than compensatory displays.
- ❑ Cathode ray tube (CRT) displays are most effective when they are seven to nine or more scan lines per millimeter.
- ❑ In the design of displays of complex configurations (such as traffic routes and wiring diagrams), avoid unnecessary detail and use schematic representation if consistent with uses.

### 13.5.5 Alphanumeric Displays

- ❑ Typography of alphanumeric characters (design, size, contrast, etc.) is especially critical under adverse viewing conditions.
- ❑ Alphanumeric characters should be presented in groups of three or four for optimum short-term memory.
- ❑ Capital letters and numerals used in visual displays are read most accurately when:
  - the ratio of stroke width to height is about 1:6 to 1:8 for black on white and somewhat higher (up to 1:10) for white on black
  - the width is at least two-thirds the height
  - single numbers, 10; single letters, 26; combination

### 13.5.6 Symbolic Displays

- ❑ Symbolic displays are designed on the basis of the following perceptual principles:
  - figure/ground
  - figure boundaries
  - closure
  - simplicity
  - unity

### 13.6 Technology Systems

- ❑ How is each employee's activity connected with the work of other productive people in a technology system?
- ❑ Many of today's organizations have enormous numbers of machines and personal computers, fax machines, high-speed copiers, laser printers, archives, and so on.—These tools, when assembled as a system, directly support the workflow process.—Overlaying the technology system onto the workflow system will reveal the degree to which the two work together.
- ❑ There are many innovations for enhancing environmental control at the workstation, with distributed sensors, handheld or computer screen controllers, integrated diagnostic units (to evaluate power overloading, temperature, light, flow of air) and for resolving acoustic problems (pagers, mouthpieces, silent rings).
- ❑ The surge in interest in healthier workplaces will result in less noise, heat, and pollution, and lower power. The desktop hardware in the office of the future will follow in most if not all of these directions, and will be the fastest changing systems in the workplace.
- ❑ While area peripherals have a useful life of 3 to 5 years, the building's HVAC and networking structures will have a life of 5 to 10 years, and the structure and enclosure will have a life of about 50 years. It is for this reason that serious investments must be made to make the building "forgiving" or "loose-fit" for the accommodation of rapidly changing peripheral and servicing systems, rather than "tight-fit" to meet only present-day equipment hardware, networking, and environmental needs.

### 13.7 ANSI B11 Technical Report

- ❑ The Machine Tool Safety Standards Committee (B11) of the American National Standards Institute took the initiative in the early 1990s to compose a voluntary standard involving the design, installation, and use of tools/machines from an ergonomics perspective to reduce workplace injury and improve product production (ANSI Technical Report: *Ergonomic Guidelines for the Design, Installation and Use of Machine Tools*).

## Human Factors to Be Considered Related to Job Competencies

### Knowledge

- Methods of work
- Materials
- Machines and equipment
- Instruments and tools
- Organization
- Environment

### Psychology

- Concentration
- Fatigue
- Emotions

### Biomechanical

- Balance, coordination
- Full range of motion
- Sitting
- Standing
- Head
- Upper extremities
- Lower extremities

### Safety

- OSHA
- ANSI
- CDC
- GHS
- EPA

### Strength and Stamina

- Lift, carry, place, transfer
- Materials, objects, people
- Weight
- Height, width, length

### Sensory

- Vision
- Hearing
- Olfactory
- Skin
- Taste
- Speech

### Quality

- ISO
- Six Sigma

The ergonomic importance of finishes is threefold: their aesthetic value, their durability and maintenance, and their safety. Work surfaces should be finished with non-slip surfaces for tools and equipment used. Finishes on surfaces should support health and safety for individuals of all functional capacities. For example, workers with bifocals may misperceive stair riser heights unless they are outlined in yellow. Color can be either very psychologically satisfying or disturbing, as well as cognitively confusing. If the workplace environment is multicultural, then the communication of color becomes important. For example, white is a symbol of purity and peace to Americans but may not be thought of as such in other cultures.

Walking and standing surfaces on which people stand for long periods should be designed to prevent slipping and provide adequate traction and comfort. Anti-fatigue floor mats, sit-stand stools, and footrests can help make workers more comfortable.

### 14.1 Ergonomic Design Benefits

- Improved safety
- Legal compliance

### 14.2 Consequences of Not Using Ergonomic Design

- Lost time
- Increased cost
- System failures
- Injury, illness, disease, fatality
- Lost quality

### 14.3 Floor Systems

- Only when the area's space distribution and usage is known can designers properly specify flooring structures—whether concrete, metal, or wood.
- Besides providing a wearing surface, floor systems also may incorporate wiring for electric power transmission, voice and data communication, and even air delivery in some cases.
- In considering the importance of flooring as a system instead of just a structural element, specialties like access flooring become commonplace considerations for today's buildings.

### 14.4 Finishes

- People require finishes that support personal image and provide safety—e.g., carpets that do not impede mobility with excessive pile depth.
- Avoid patterns that are too busy as they may cause confusion.
- Wall surfaces should be smooth to prevent abrasions to people leaning on handrails.
- Surface coverings should support the health and safety of individuals, no matter what their functional limitations.
- All surfaces should be easily maintainable, with smooth wall coverings and/or laminated surfaces.

## 14.5 Floors

- All flooring and flooring materials must meet the National Fire Code, Class I.
- Level-loop carpeting should be used in areas where people walk in order to provide a pleasant walking surface and reduce glare and noise.
- Direct-glue carpeting should be used to prevent slipping and rolling resistance to wheelchairs.
- Where water absorbency is an issue, jute backing is safest.
- Floors should be relatively light in color, with 30%–50% reflectance.

## 14.6 Walls

- Brick, concrete, and tile are the most resistant to abuse from contact.
- Surfaces should be smooth to prevent abrasions.
- Glare should be minimized whenever possible. Reflectance should be 40%–60%.

## 14.7 Ceilings

- Texture, pattern-paint, or fabric-cover should be used to provide visual relief and serve as an aid to orientation.
- Reflectance should be 70%–90%.

## 14.8 Color Choices

- Creative and innovative use of color through paint and other decorative materials is an easy way to improve a tired facility's aesthetics and move away from the interiors of traditional institutions.
- A typical updated room may now feature artwork, creative use of paint in contrasting tones, and attractive wall coverings with broad appeal.
- Color plays a central role in this move away from “institutional” interiors to a warmer, more comfortable look. Today, it's not enough to “paint everything blue” in an attempt to provide a comfortable, calming effect.
- Knowing the basics of color and how to use it as a tool are important steps in creating an environment appropriate to today's work environments.
- Research has shown that color can influence human behavior. Cool colors, such as blues and greens, calm and soothe. Warm colors, such as reds and yellows, stimulate the senses.
- Although no concrete rules on the use of color exist, following some simple guidelines will optimize the placement of color in your facility.

## 14.9 Color's Impact

- How and where colors are used make a dramatic difference based on the size of space, how the space is used, and available light.
- Work areas, such as laboratories and workstations, should use cool colors or those with a high ability to reflect light.
- Intensive environments such as these function best when colored with light-reflective hues. These tones improve visibility and reduce shadows, which tend to enhance productivity.

- ❑ By making the work area easier to see, the use of cool colors also helps to ease tension and provide a comfortable, non-distracting environment. Work areas should employ these colors to promote an uplifting and safe environment.
- ❑ Areas that serve more social needs—like cafeterias, lounges, and lobbies—should employ warmer, bolder colors that help encourage conversation.
- ❑ Color selection for break rooms depends largely on the duration for which the rooms are used. Today’s trend for comfortable break rooms leaves less room for boredom. As a result, color choices can lean more toward the neutral or pastel palettes, with brighter accent colors adding visual interest.
- ❑ In older facilities, rooms should provide a balance of color, a mix of contrasting tones that keep the space looking fresh and interesting day-in and day-out.
- ❑ Bear in mind that older workers usually occupy mature facilities. This, coupled with the limited availability of natural and artificial light, will make a significant impact on which colors are selected and how they ultimately will appear to the staff’s eyes.

### 14.10 Positive Values

- ❑ Color communicates value and image.
  - Out-of-date color schemes may inadvertently project a run-down, neglected appearance, while colors reflecting current lifestyles and fashion communicate a successful, well-maintained facility.
- ❑ This decade’s color palettes are bolder than in years past, combining timeless neutrals with such confident shades as sophisticated violets and optimistic yellows.
- ❑ In manufacturing facilities, the use of the right combination of colors will emphasize positive design elements while minimizing unattractive ones.

**Table 14.1 Types of finishes and their properties**

<i>Product</i>	<i>Respiratory protection</i>	<i>Number of coats</i>	<i>Drying time</i>	<i>Color</i>	<i>Sheen</i>	<i>Odor</i>	<i>Flammability</i>
Oil-modified urethane	Required	2–3	Slow	Amber	Satin to gloss	Moderate	Combustible
Water-borne urethane	Required	2–4	Fast	Clear to amber	Satin to gloss	Mild	Non-combustible
Moisture-cured urethane	Required	2–3	Slow to fast (depending on humidity)	Clear to dark amber	Satin to gloss	Strong	Combustible to flammable
Conversion varnish	Required	2–3	Fast	Clear to slight amber	Satin to gloss	Very strong	Combustible
Wax	Optional	1–3	Fast	Slight amber	Wax luster	Mild	Combustible

- ❑ The importance of projecting an up-to-date look bears greater significance in quality-managed settings where state-of-the-art, high-tech care and services are expected—even demanded—by customers and staff.
- ❑ Just as the presence of technological devices builds confidence, a facility that projects an up-to-date image reinforces that confidence.
- ❑ Keep in mind that “up-to-date” doesn’t mean trendy. In fact, most trendy or “in” looks date themselves more rapidly in the constantly changing environment than in many other settings.
  - Trendy or theme approaches (like a Southwestern or 1950s motif) usually work best for hospitality and restaurant surroundings where the mood is light and festive, and time spent there is limited.
- ❑ In a manufacturing setting where expectations are more serious, it’s best to apply the basics of good design by choosing colors based on a range of complementary combinations and palettes.
- ❑ The use of color emphasizes positive design elements and minimizes unattractive ones. Color choice draws attention to or away from interior and exterior features. This is especially true in renovation projects where old or existing structures must be incorporated into the updated space.
- ❑ Using understated colors that blend and coordinate can showcase handsome finishes, such as natural marble or rare hardwoods. This allows the focal point to remain on the material itself.
- ❑ The unattractive color of a tile or laminate can be downplayed with the introduction of a distinctly different color scheme. For example, painting columns, beams, and pipes in the same color as an adjacent wall or ceiling will have a camouflaging effect.
- ❑ Defining space with color draws attention to specific areas and highlights physical details.
  - Large facilities have depended on color as a coding mechanism for years, enabling visitors and staff to navigate through even the most complicated floor plans by following color-coded signs, maps, or floor markers.
- ❑ Safety engineers rely on standardized colors designated by the OSH Act and ANSI to call attention to potential physical hazards. These allow workers to locate hazards and safety devices quickly.
  - Orange signifies dangerous equipment.
  - Yellow signifies caution or physical hazards.
  - Green signifies first aid stations.

### 14.11 Practical Approach

- ❑ With today’s broad range of colors in paints, fabrics, wall coverings, and furnishings, the variety of possible color combinations is endless.
- ❑ Bear in mind that many materials used in the hospitality industry simply are not designed to hold up to the abuse from equipment particulate and harsh cleaning agents.
- ❑ Stick to top-quality materials made specifically for the manufacturing setting. These products will help create surroundings that are attractive and practical.

- ❑ Color plays a key role in striking a balance between function and aesthetics.
- ❑ A well-detailed plan for color selections can save time and valuable resources by providing a strategy for future expansion.
- ❑ A well-thought-out color plan will liven up tired, institutional-looking facilities and help create a positive atmosphere.

## Human Factors to Be Considered Related to Job Competencies

### Knowledge

- Methods of work
- Materials
- Machines and equipment
- Instruments and tools
- Organization
- Environment

### Psychology

- Concentration
- Fatigue
- Emotions

### Biomechanical

- Balance, coordination
- Full range of motion
- Sitting
- Standing
- Head
- Upper extremities
- Lower extremities

### Safety

- OSHA
- ANSI
- CDC
- GHS
- EPA

### Strength and Stamina

- Lift, carry, place, transfer
- Materials, objects, people
- Weight
- Height, width, length

### Sensory

- Vision
- Hearing
- Olfactory
- Skin
- Taste
- Speech

### Quality

- ISO
- Six Sigma

The ergonomic importance of furnishings is to consider the ergonomic design, comfort, and functionality of workstations and seating positions. The idea is to create work areas that support effective tasks and routines while allowing the body to be supported in postures and positions that enhance the work effort without creating stress, strain, and fatigue. The criteria for selecting furnishings should begin with a database of the real worker population to establish the norms and outliers in the work group. Purchasing decisions should be made based on performance in the workplace, not just on cost or long-term vendor relationships.

Ergonomics is an overused marketing word in the furniture industry. There is no one chair or work station that “fits all.” The design criteria for furnishings should consider the comfort and convenience of the users and observers related to the operating work areas. Furnishing considerations fall into several categories of need, such as visual tasks, primary controls to visual tasks (e.g., keyboard to computer monitor), control display relationships (e.g., phone system, adding machines), arrangement of all necessary elements (e.g., microscope, notebook, samples), and consistency with other layouts in the system.

### 15.1 Ergonomic Design Benefits

- Improved safety
- Legal compliance

### 15.2 Consequences of Not Using Ergonomic Design

- Lost time
- Increased cost
- System failures
- Injury, illness
- Disease
- Fatality
- Lost quality

### 15.3 Evaluating and Selecting Ergonomic Furniture and Equipment

The more interesting activities of the office ergonomics team involve evaluating the different kinds of ergonomic products on the market; however, many problems during facilities implementation can occur if certain issues are not considered. It is important to first evaluate existing facilities standards, inventory processes, accounting methods, and procurement procedures before purchasing any new products. The following questions should be asked:

- Are any ergonomic products being used now?
- What types of ergonomic products need to be evaluated and specified?
- What criteria should be used to evaluate the ergonomic products?
- Who will oversee product evaluation and specifications?
- Will only one product be specified per item or will more than one manufacturer be used?

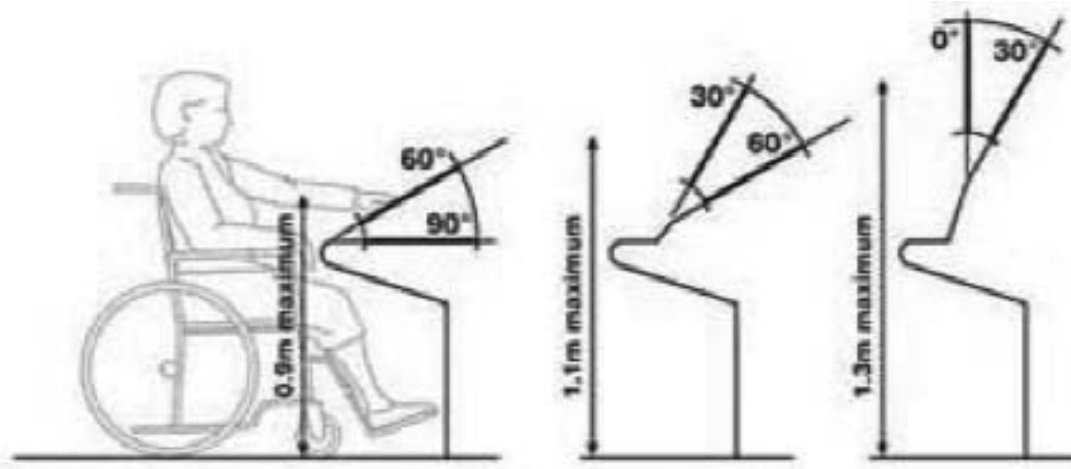

**Figure 15.1.** Furnishings can be modified to add access and reduce glare.

- Where should a prototype area be set up?
- What sources can be used to obtain products for evaluation?
- What are the existing facility's standards? What ergonomic products can meet these standards? Can these products be integrated into existing panel and furniture systems?
- What improvements can be made to ensure the most impact on facility modification?
- What physical properties need to be considered?
- What changes need to be made to the facility's standards manual?

### 15.3.1 Workstation Design

- A workstation design that includes seating, work surface, and work-surface technologies is intended to maximize the physical capabilities of the worker and to prevent injuries to the body.
- The design should allow optimum mobility and variation in positioning in order to improve the five physical conditions known to affect the capacity to work:
  - circulation
  - movement
  - force exertion
  - use of the correct muscles for tasks
  - recovery time

## Human Factors to Be Considered Related to Job Competencies

### Knowledge

- Methods of work
- Materials
- Machines and equipment
- Instruments and tools
- Organization
- Environment

### Psychology

- Concentration
- Fatigue
- Emotions

### Biomechanical

- Balance, coordination
- Full range of motion
- Sitting
- Standing
- Head
- Upper extremities
- Lower extremities

### Safety

- OSHA
- ANSI
- CDC
- GHS
- EPA

### Strength and Stamina

- Lift, carry, place, transfer
- Materials, objects, people
- Weight
- Height, width, length

### Sensory

- Vision
- Hearing
- Olfactory
- Skin
- Taste
- Speech

### Quality

- ISO
- Six Sigma

**H**ousekeeping requires working around design, division, and density of space to maintain facilities cleanliness. Housekeepers must pay attention to work methods that maintain safety standards within common and work areas, passageways, and storage facilities, while managing waste. Ergonomics and housekeeping work in concert as a basic part of accident prevention (slips, trips, and falls) and fires. The importance of ergonomics for housekeepers is the elimination of postures that are strenuous and awkward at the same time. Ergonomics is effective in eliminating workplace hazards for housekeepers when force, awkward posture, repetition, and duration are minimized.

Housekeeping is one of the most important aspects of job safety. Poor housekeeping techniques lead to workplace injury for workers throughout facilities. Poor housekeeping affects specific job titles such as material handlers, programmers, and equipment operators. Ergonomically sound housekeeping techniques can reduce accidents by eliminating hazards that cause injuries. Housekeeping tasks are important because when done correctly they remove the paper, debris, clutter, and spills that can cause serious health and safety hazards.

Housekeeping tasks should be a shared effort in all work areas to maintain cleanliness. That includes keeping work areas neat and orderly, maintaining halls and floors free of slip and trip hazards, and removing waste materials (e.g., paper, cardboard) and other fire hazards from work areas. Effective housekeeping is an ongoing operation; it is not a hit-and-miss cleanup done occasionally. Periodic “panic” cleanups are costly and ineffective in reducing accidents.

### 16.1 Ergonomic Design Benefits

- Improved productivity
- Improved safety
- Improved quality
- Legal compliance

### 16.2 Consequences of Not Using Ergonomic Design

- Lost time
- Legal citation
- Injury, illness
- Disease
- Fatality
- Lost quality

### 16.3 Improving the Match of Worker Capabilities to Methods of Work

- Define the job by competencies for knowledge, psychology, biomechanics, sensory, strength and stamina, safety, and quality.
- Validate job demands by intensity of the requirement (common sense to expert).
- Conduct job safety analysis.
- Validate job demands by frequency and severity of risk.
- Prescreen.

- Use industry-specific testing, task simulation.
- Prescreen workers at each stage of employment.
  - first hired, lateral moves, promotion, return to work
- Screen for essential functions that may be validly compromised by age, disease, disability, injury.
- Integrate the knowledge, psychological, safety, and quality competencies of business requirements with the physical and sensory demands.
- Physical: Coordinate and cross-train workers on static and dynamic postures to reduce occupational stress.
- Cross-training could include maintaining accessibility, finishes, passages, and waste management.
- Create safe action protocols such as “Working with Liquids in Housekeeping,” for use in housekeeping areas when filling and emptying buckets with floor drain arrangements. This reduces risk of spills and slips, speeds process, and reduces waste.
  - The faucet and floor drain are used in housekeeping.
  - Ensure that casters don’t get stuck in floor grate.
  - Use hose to fill bucket.
  - Use buckets with casters to move mop bucket around.
  - Ensure casters are maintained and roll easily.
- Sensory: Set up work carts to increase eye, hand, and all sensory coordination (sight, hearing, touch, smell, taste).

#### 16.4 Improving the Methods of Work

- Administrative controls
- Proper training
- Rest breaks
- Variety of job tasks

#### 16.5 Improving the Materials of Work

- Have a housekeeping program that plans and manages the orderly storage (bins and closets) and movement of cleaning materials from point of entry to exit. It includes a flow plan to ensure minimal debris and dirt transfer.
- Integrate the knowledge competencies of cleaning chemicals (MSDSs) and equipment use with a maintenance plan that reduces the risk of physical and sensory demands.
- Coordinate and cross-train workers on the properties of materials and handling equipment that could cause risk

organic	fabric	plastic
solid	metal	rubber
fluid	mineral	synthetic
composite	nano	wood
chemical	nylon	

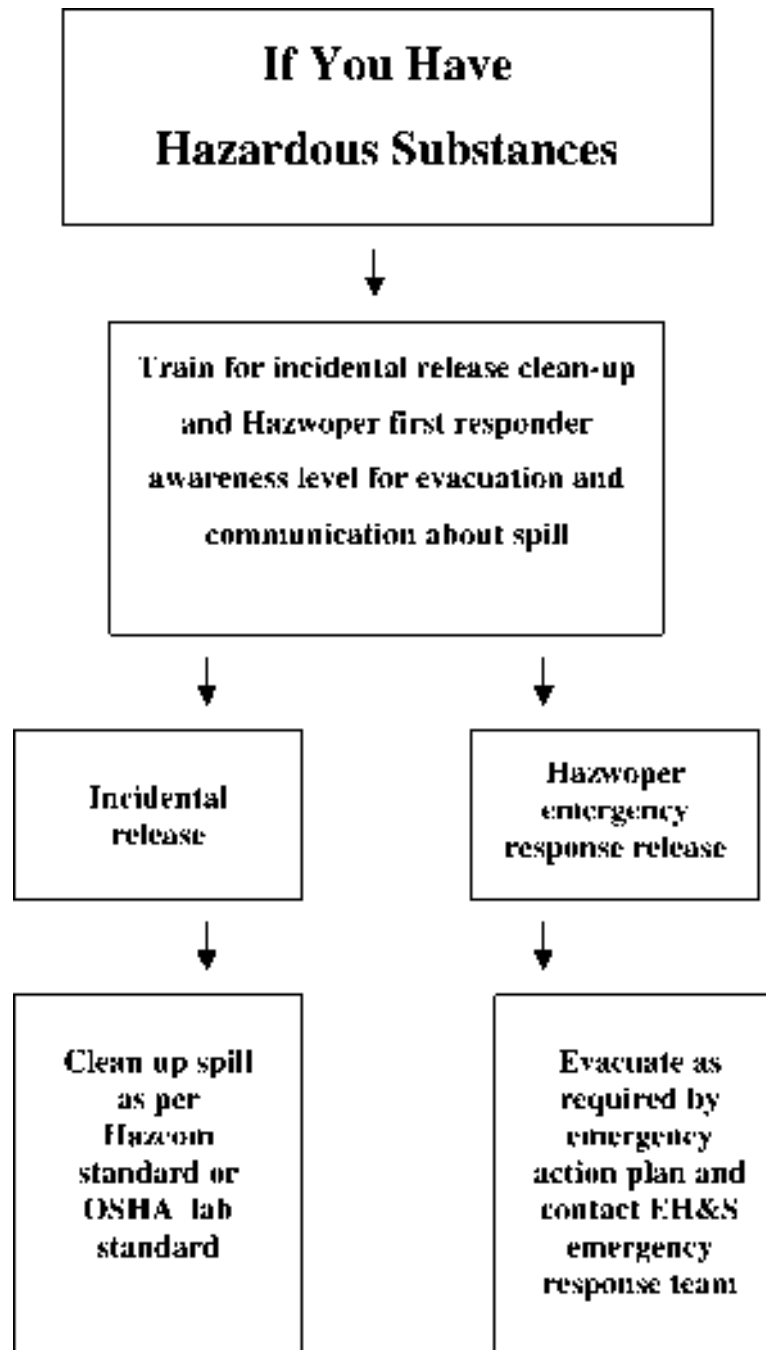

Figure 16.1. Housekeeping requires policy and training for safe action.

- Physical and sensory: Create solutions to tag type of product used in varying cleaning protocols
- Sensory: Very important when mixing chemicals for cleaning that the mix of solution concentrates is accurate.

### **16.6 Improving the Equipment and Machines of Work**

- Control the access point for workers to reduce awkward postures.
- Tripping over loose objects on floors, stairs, and platforms.
- Being hit by falling objects.
- Slipping on greasy, wet, or dirty surfaces.
- Striking against projecting or poorly stacked items or misplaced material.
- Cutting, puncturing, or tearing the skin of hands or other parts of the body on projecting nails, wire, or steel strapping.
- Use preventive maintenance of equipment and machines to reduce force needed to work with or on equipment and machines.
- Match just-in-time processing with consideration to worker schedules. Reduce overtime demands.
- Create solutions, from simple stock locator solutions to advanced real-time system-directed solutions, that would be integrated with automated materials handling equipment and new innovations, such as voice recognition technology.
- Set up computers at correct heights and create web visibility of inventory, orders, and shipments, or through other e-commerce collaborative efforts.

### **16.7 Improving the Instruments and Tools of Work**

- Purchase ergonomic tools with non-slip surfaces for grip surfaces under all conditions.
- Set up cleaning carts with ease of access, limited lifting.
- In some jobs, enclosures and exhaust ventilation systems may fail to collect dust, dirt, and chips adequately. Vacuum cleaners are suitable for removing light dust and dirt. Industrial models have special fittings for cleaning walls, ceilings, ledges, machinery, and other hard-to-reach places where dust and dirt may accumulate.
- Dampening floors or using sweeping compounds before sweeping reduces the amount of airborne dust. The dust and grime that collect in places like shelves, piping conduits, light fixtures, reflectors, windows, cupboards, and lockers may require manual cleaning.
- Special-purpose vacuums are useful for removing hazardous substances. For example, vacuum cleaners fitted with HEPA (high-efficiency particulate air) filters may be used to capture fine particles of asbestos or fiberglass.

### **16.8 Improving the Organization of Work**

- Use software to design work areas and create dynamic routing that optimizes the flow of housekeeping to critical and remote areas.
- Reduce handling to ease flow of materials.
- Become clutter-free and spill-free in work areas.

- Decrease fire hazards.
- Lower worker exposures to hazardous substances.
- Better control of tools and materials
- Use more efficient equipment cleanup and maintenance for better hygienic conditions, leading to improved health.
- Use space more effectively to reduce property damage.
- Improve preventive maintenance to reduce janitorial work needed.

### **16.9 Improving the Environment of Work**

- Integrate accessibility, adaptability, density, and design of space, lighting, passages, and training into safety components of housekeeping.
- The final addition to any housekeeping program is inspection. It is the only way to check for deficiencies in the program so that changes can be made. The documents on workplace inspection checklists provide a general guide and examples of checklists for inspecting offices and manufacturing facilities.
- Health/sanitation issues: The general facility sanitation systems should be inspected and tested to guard against potential employee exposure to toxic agents.
- Food sanitation should also be an issue. Any unused foodstuffs should be discarded. If the workspace has a kitchen, inspect oven hoods and other ventilation devices to ensure they are not clogged and are working efficiently.
- Maintain a protocol for hazardous substances.

## Human Factors to Be Considered Related to Job Competencies

### Knowledge

- Methods of work
- Materials
- Machines and equipment
- Instruments and tools
- Organization
- Environment

### Psychology

- Concentration
- Fatigue
- Emotions

### Biomechanical

- Balance, coordination
- Full range of motion
- Sitting
- Standing
- Head
- Upper extremities
- Lower extremities

### Safety

- OSHA
- ANSI
- CDC
- GHS
- EPA

### Strength and Stamina

- Lift, carry, place, transfer
- Materials, objects, people
- Weight
- Height, width, length

### Sensory

- Vision
- Hearing
- Olfactory
- Skin
- Taste
- Speech

### Quality

- ISO
- Six Sigma

Image is an important ergonomic consideration in enhancing the friendliness of an environment. The coordination of color and finishes invites the use of a work area and reduces psychological stress by giving a sense of flow between the user and the environment. The fewer visible wires, the more organized an area is perceived to be. The more art that is added to the vistas of an area, the less constrained the user feels. The more coordinated the overall image is, the more valued employees feel. The more valued an employee feels, the more productive he or she will be. In these ways, image definitely counts.

### 17.1 Ergonomic Design Benefits

- Improved safety
- Legal compliance

### 17.2 Consequences of Not Using Ergonomic Design

- Lost time
- Increased cost
- System failures
- Injury, illness
- Disease
- Fatality
- Lost quality

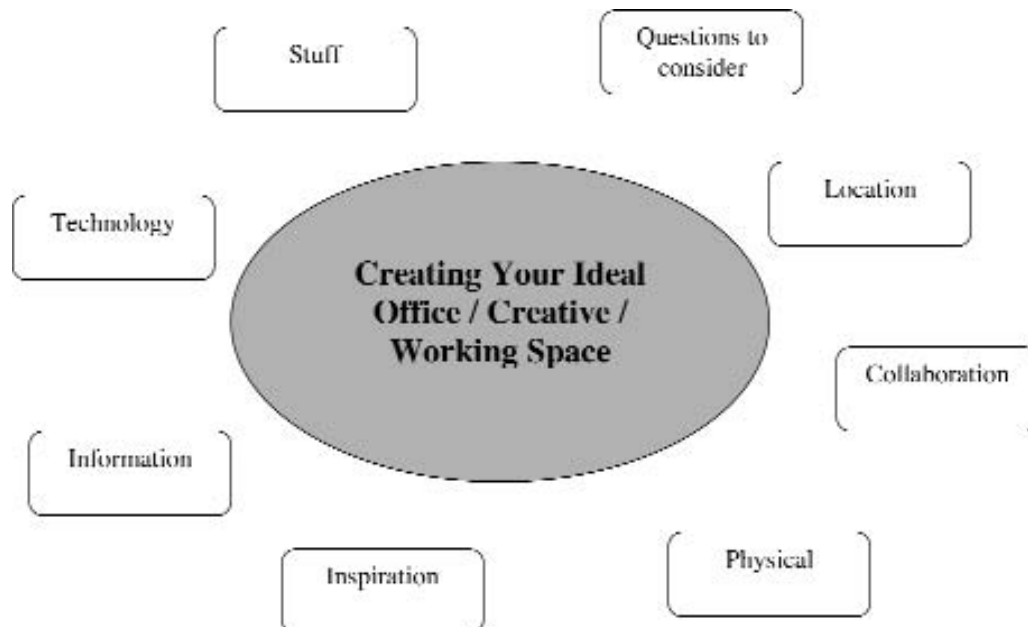

Figure 17.1. Image: An ideal office.

### 17.3 Image (Signage, Atriums, Quiet Rooms, Finishes)

- ❑ A facility is unique in its size, configuration, climate, site topography, and relationship to other elements of the environment.
- ❑ Each facility offers employees different amenities, levels of service, and work site supports.
- ❑ Each property has a unique mix of people in business with different backgrounds, interests, ages, and salaries.
- ❑ The objective of most managers is to maintain a reasonable return on investment.
- ❑ The design of a facility and the associated construction costs are significant factors in meeting the objective of image.
- ❑ Scope is a term commonly used in designing to describe the number of image elements required in a specific project. How many executive areas vs. “bull pen” work sites will there be? Requirements for scope vary depending on the corporate commitment to image.
- ❑ Image requirements establish the minimum number of design elements for a specific project.
- ❑ Owners or developers may elect the minimum requirements if, in their judgment, increased image will not provide greater satisfaction.
- ❑ Marketing surveys and other sources of information are usually available to owners or developers to help determine any appropriate increase in the number of image elements.

### 17.4 Cost

- ❑ Cost should not always be a factor. For example, multi-use spaces will cost the same as single-use spaces. In many cases, image features benefit all, and the decision to include such features is simply a marketing decision.
- ❑ Each case requires judgment. Therefore, developers and designers are encouraged to examine alternatives, not simply to provide the minimum number of image elements.

Precise analysis of costs for image features cannot be provided in this book because of the wide range of sizes and finishes in standard designs for facilities. Costs also vary for different functional areas within a property and are affected by the total number of elements constructed. Design features generally have a relatively higher cost in smaller and less expensive properties.

## Human Factors to Be Considered Related to Job Competencies

### Knowledge

- Methods of work
- Materials
- Machines and equipment
- Instruments and tools
- Organization
- Environment

### Psychology

- Concentration
- Fatigue
- Emotions

### Biomechanical

- Balance, coordination
- Full range of motion
- Sitting
- Standing
- Head
- Upper extremities
- Lower extremities

### Safety

- OSHA
- ANSI
- CDC
- GHS
- EPA

### Strength and Stamina

- Lift, carry, place, transfer
- Materials, objects, people
- Weight
- Height, width, length

### Sensory

- Vision
- Hearing
- Olfactory
- Skin
- Taste
- Speech

### Quality

- ISO
- Six Sigma

The importance of ergonomics and instruments is that their fit is critical to eye-hand coordination that must be exact (micrometers). Instruments are both handheld and part of fixed workstations, such as microscopes. Quality control instruments require hand stability for exact readability (numbers, characters, graphs). Instruments are typically found in macro environments that range from manufacturing quality stations to nanotechnology laboratories.

In the case of handheld instruments, professionals often report suffering from ergonomically inadequate handle designs. Instruments that create tip force transmission can cause a near miss on material or for the worker. Poor handheld instruments can lead to fatigue, discomfort, and hand paresthesias.

Improvements in the design of instruments are needed to decrease the discomfort of material manipulation, such as tissue, during procedures as well as high-contrasted points for usability. Examples of increased usability are color-coded handles to designate instrument function and contrasted brightness to increase readability. Microscopes are instruments that are a consistent fixture in laboratories where quality control and inspections of materials are conducted. Ergonomics is concerned with applying design and specification criteria that will enhance user comfort by eliminating awkward postures and force. Ergonomically designed instruments such as tweezers and microscopes can reduce fatigue and cumulative stress (neck strain). Quality microscopes should have enhanced modularity built in. Modularity allows for easy adjustments to accommodate diverse physical requirements (upper body and hands).

The ultimate ergonomic goal is to reduce the risk of cumulative stress of awkward postures, force, repetition, and duration. Instruments used in cold stress environments require special consideration. Quality, health, and safety standards and regulations identify known hazards. Job safety analysis defines the risk. Ergonomic principles define the instrument need. People and their human factors dictate “fit.” The ergonomic goal of instruments is to fit the individual worker, be appropriate for the task being done, and not contribute to extreme postures, excessive constraining force, repetition, or duration. The optimum goal of ergonomically correct instruments is comfort, health, and performance in macro environments.

### 18.1 Ergonomic Design Benefits

- Improved productivity
- Improved safety
- Improved quality
- Legal compliance

### 18.2 Consequences of Not Using Ergonomic Design

- Lost time
- Legal citation
- Injury, illness
- Disease
- Fatality
- Lost quality

### 18.3 Improving the Match of Worker Capabilities to Methods of Work

- ❑ Define the job by competencies for knowledge, psychology, biomechanics, sensory, strength and stamina, safety, and quality.
- ❑ Validate job demands by intensity of the requirement (common sense to expert).
- ❑ Conduct job safety analysis.
- ❑ Validate job demands by frequency and severity of risk.
- ❑ Prescreen.
- ❑ Industry specific testing, job task simulation.
- ❑ Prescreen workers at each stage of employment.
  - First hired, lateral moves, promotion, return to work
- ❑ Screen for essential functions that may be validly compromised by age, disease, disability, injury.
- ❑ Job safety analysis factors may dictate screening for human factors consequences, PPE, and competence to take safe actions.
- ❑ Biomechanical:
  - grip with gloves and force required to manipulate instruments and materials
  - neck strength to maintain flexion and extension
  - range of motion for reach that does not impede reflexes and is coordinated with peripheral vision
- ❑ Sensory:
  - hearing: acuity to distinguish sounds
  - vision: acuity to distinguish objects of microscopic size through optical lens
  - smell: acuity to determine smell in air-quality-controlled spaces
  - sensation: acuity to distinguish temperature through gloves
  - taste: acuity to distinguish sweet, sour, bitter, salty

### 18.4 Improving the Methods of Work

- ❑ Integrate the knowledge, psychological, safety, and quality competencies into the physical and sensory demands.
- ❑ Control the access points to instruments to allow operators to sit erect, in a good ergonomic neutral posture, and reduce neck flexion.
- ❑ Employees often rotate through microscope workstations. It is difficult to adjust workstations and equipment for each individual.
- ❑ Create workstations with instruments that effectively respond to the diverse physical requirements of their users.
- ❑ Physical: Coordinate and cross-train workers on the integrated fit of all PPE for specific job tasks; allow operators to customize the viewing angle of the binocular tube, reducing neck flexion and increasing comfort and support.
- ❑ Sensory: Support each sensory element.
  - seeing/visibility (design and LED light)
  - recognizability/identification (colors and symbols)
  - tactile feeling (soft silicone materials)
  - control (functional positioning and form)
  - sensitivity and reachability (dimensions)
  - minimal force (light weight and efficiency)

- Sensory: Set up work protocols to increase eye-hand and all sensory coordination (sight, hearing, touch, smell, taste)
- PPE: Gloves can protect the hands from injury or cold, but they also may reduce dexterity and increase grip force. When choosing instruments, consider these factors:
  - Gloves should be small enough to minimize wrinkling or slipping but large enough so they don't impede circulation.
  - Texturing improves friction. If chemical resistance is not a concern, material should be breathable so perspiration is not trapped.
- Create safe action protocols for high repetition and duration tasks.

### **18.5 Improving the Materials of Work**

- Purchase laboratory materials with lowered risk, such as water soluble testing chemicals.
- Integrate the knowledge competencies of safe actions when using PPE with materials and moving material using handling equipment.

### **18.6 Improving the Equipment and Machines of Work**

- Control the access points to hazards to reduce risk.
- Control the sensory overload of noise with sound dampening.
- Create solutions that increase automation.
- Microscopic data transfer to software databases.

### **18.7 Improving the Instruments and Tools of Work**

- Control the eye-hand coordination of workstation access points to instruments that are handheld or microscopes to maintain a 180-degree radius.
- Microscopes should be highly flexible, allowing technicians to vary a microscope's height on demand. A simple twist of the locking knob should allow technicians to change the height by as much as four inches without changing the viewing angle.
- Microscopes should rotate 180 degrees for right- or left-hand operation.
- Binocular microscopes should allow operators to comfortably move back from their work in a supported, neutral posture.
- Microscopes should have optical and mechanical modifications increase the magnification.
- Accommodate situations where operators use long working distance objective lenses.

### **18.8 Improving the Organization of Work**

- Optimize work processes to support sequencing.
- Integrate instruments into stations in the right work areas.
- Train and cross-train to allow for job rotation.

## 18.9 Improving the Environment of Work

- ❑ Optimize the work environment for both the mental and physical state of workers.
- ❑ Signage is key to work area identifiers for safety protocol.
- ❑ Integrate accessibility, adaptability, benchmarking, comfort, density, design of space, housekeeping, lighting, passages, PPE, quality, software, temperature, training, and waste management into safety components of instrument use.

## Human Factors to Be Considered Related to Job Competencies

### Knowledge

- Methods of work
- Materials
- Machines and equipment
- Instruments and tools
- Organization
- Environment

### Psychology

- Concentration
- Fatigue
- Emotions

### Biomechanical

- Balance, coordination
- Full range of motion
- Sitting
- Standing
- Head
- Upper extremities
- Lower extremities

### Safety

- OSHA
- ANSI
- CDC
- GHS
- EPA

### Strength and Stamina

- Lift, carry, place, transfer
- Materials, objects, people
- Weight
- Height, width, length

### Sensory

- Vision
- Hearing
- Olfactory
- Skin
- Taste
- Speech

### Quality

- ISO
- Six Sigma

The importance of ergonomics to interplant transfer is to design the methods of work as part of the logistics strategy of labor management. Warehouse management systems are too often viewed as equipment solutions (forklifts) that manage product movement. Ergonomics optimizes interplant transfer by taking people into consideration as part of the four walls of activities taking place within a plant or distribution center.

The use of ergonomics in a labor productivity system is to match worker competencies and minimize the risks of interplant transfers such as material handling and moving between hot and cold environments. The positive results of using ergonomic principles are to match business solutions such as monitoring the amount of direct warehouse labor required to safe warehouse operations. Two examples are stock movement and order-picking activities. Ergonomic solutions are part of warehouse management systems because they integrate workers' knowledge competencies about parts and product data to biomechanical and sensory competencies used to move product safely and accurately. Ergonomic analysis of interplant transfer strategies aligns the most biomechanically fit (driving and depressing the foot pedal of a forklift) person to a work method to get the work efficiently completed. Ergonomic understanding of work demands reduces risk and increases labor force competencies. A job demand that is understood (using peripheral vision vs. head turning) supports interplant transfer times by specifying the labor time required to execute tasks, within safety standards.

Ergonomics used in conjunction with XYZ interplant transfer coordinates can match people strengths and stamina to flow and transport of goods. That means moving in and out of work areas to stock interplant locations. Many firms use ergonomics to create interplant transfer strategies that match and track worker performance within productivity, safety, and quality standards.

### 19.1 Ergonomic Design Benefits

- Improved productivity
- Improved safety
- Improved quality
- Legal compliance

### 19.2 Consequences of Not Using Ergonomic Design

- Lost time
- Legal citation
- Injury, illness
- Disease
- Fatality
- Lost quality

### 19.3 Improving the Match of Worker Capabilities to Methods of Work

- Define the job by competencies for knowledge, psychology, biomechanics, sensory, strength and stamina, safety, and quality
  - Validate job demands by intensity of the requirement (common sense to expert).

- ❑ Conduct job safety analysis
  - Validate job demands by frequency and severity of risk
- ❑ Prescreen
  - Industry-specific testing and job simulations
  - Prescreen workers at each stage of employment
  - First hired, lateral moves, promotion, return to work

#### 19.4 Improving the Methods of Work

- ❑ Integrate the knowledge competencies of business requirements with the physical and sensory demands.
- ❑ Physical:
  - Coordinate and cross-train workers on static and dynamic postures to reduce occupational stress. Cross-training could include order processing, and transportation of inventory from manufacturing to warehousing.
  - Teach workers to select the rack or bin that suits the task for safe and quality product transfer.
- ❑ Physical and Sensory:
  - Create solutions from tag tracking of product to simple bar code stock locators.
  - Sensory: Voice recognition technology enables warehouse transport managers and forklift operators and material handlers to give and receive voice instructions from a headset that enables the paperless environment. This increases order accuracy, real-time inventory transport, and integration of cross-department personnel knowledge (accounting for diversity).

#### 19.5 Improving the Materials of Work

- ❑ Scale the dimensions of materials to increase interplant transfer.
- ❑ Use pallets that do not splinter.
- ❑ Shrink-wrap to pallet to stabilize the load.
- ❑ Label for long-range visibility.

#### 19.6 Improving the Equipment and Machines of Work

- ❑ Scale the access points for workers to reduce overreach postures.
- ❑ Select the right material handling for interplant transfer.
- ❑ Rotate transport trucks and cart use to prevent repetition.
- ❑ Use preventive maintenance of equipment and machines to reduce force needed to work with or on equipment and machines.
- ❑ Match just-in-time processing with consideration to worker schedules. Reduce overtime demands.
- ❑ Create solutions from simple stock locator solutions to advanced real-time system-directed solutions that would be integrated with automated materials handling equipment and new innovations, such as voice recognition technology.
- ❑ Set up computers at correct heights and create web visibility of inventory, orders, or shipments or through other e-commerce collaborative efforts.

**Table 19.1 Recommended limits in the selection of hand and powered trucks and carts**

<i>Type of truck or cart</i>	<i>Maximum load</i>		<i>Maximum transport distance</i>		<i>Maximum frequency</i>	<i>Minimum aisle width</i>		<i>Type of transfer to and from truck (+)</i>
	<i>kg</i>	<i>lb</i>	<i>m</i>	<i>ft</i>	<i>units</i>	<i>m</i>	<i>ft</i>	
					<i>(per 8-hr shift)</i>			
2-wheeled hand cart	114	250	16	50	200	1.0	3	Ma, P
3-wheeled hand cart	227	500	16	50	200	1.0	3	Ma, P
4-wheeled hand cart	227	500	33	100	200	1.3	4	Ma, P
Hand pallet truck	682	1500	33	100	200	1.3	4	Me, UL
Electric pallet truck	2273	5000	82	250	400	1.3	4	Me, UL
Electric hand-jack lift truck	2273	5000	33	100	400	1.3	4	Me, UL
Power low-lift truck	2273	5000	328	1000	400	2.0	6	Me, P, UL
Electric handstacking truck	682	1500	82	250	400	1.3	4++	Me, UL
Power fork truck	2273	5000	164	500	400	2.0	6++	Me, UL

### 19.7 Improving the Instruments and Tools of Work

- By work areas, integrate the throughputs between departments to quality labs test instruments.
- Purchase ergonomic tools and use ergonomic setup guidelines to meet task demands.

### 19.8 Improving the Organization of Work

- Use software to create dynamic routing that optimizes the assignment of inbound product parts and outbound orders applications. Create dynamic schedules that deploy for multiple stops per load.
- Use digitized plant networking to develop accurate times for product or load transfers being routed.

### 19.9 Improving the Environment of Work

- Integrate air quality, density, design of space, lighting, passages, and signage as components of interplant transfer.

## Human Factors to Be Considered Related to Job Competencies

### Knowledge

- Methods of work
- Materials
- Machines and equipment
- Instruments and tools
- Organization
- Environment

### Psychology

- Concentration
- Fatigue
- Emotions

### Biomechanical

- Balance, coordination
- Full range of motion
- Sitting
- Standing
- Head
- Upper extremities
- Lower extremities

### Safety

- OSHA
- ANSI
- CDC
- GHS
- EPA

### Strength and Stamina

- Lift, carry, place, transfer
- Materials, objects, people
- Weight
- Height, width, length

### Sensory

- Vision
- Hearing
- Olfactory
- Skin
- Taste
- Speech

### Quality

- ISO
- Six Sigma

Job safety analysis (JSA) creates a valid and reliable documentation of the qualified nature and quantified degree of observed workplace ergonomic hazards. Risk managers, safety committee members, employees, and supervisors can be trained to do consistent JSAs. All stakeholders should work cooperatively to identify contributing ergonomics risk factors. This will allow cost-effective application of ergonomics technology to change the workplace to reduce and/or eliminate risks. Using engineering controls, supervision that role models and recognizes safe actions, accommodation that resources job demands, and training minimize risks. The optimum is to eliminate, accommodate, mechanize, automate, or robotize.

### 20.1 Ergonomic Design Benefits

- Improved productivity
- Improved safety
- Improved quality
- Legal compliance

### 20.2 Consequences of Not Using Ergonomic Design

- Lost time of workers
- Increased cost of training or rework
- Legal citation
- Injury, illness
- Disease
- Fatality
- Lost quality

### 20.3 How, Why, What, Where, Who

Using the Job Smart System, human factors are specifically considered for each job safety analysis (JSA) by job title, by competencies specifically, knowledge, psychological, biomechanics, sensory, strength and stamina, safety, quality. The Job Smart System JSA comprehensively quantifies job demands beyond the physical to include neurological, intellectual (problem solving), and psychological characteristics. The reason for such specificity of worker demands is to minimize risk to workers in life transitions, e.g., change in age, size, physical condition, return to work release, or medical history. When JSA documents the demand, prescreening and job task accommodation using the best application of ergonomics technology is clear. Risk management is a system where productivity, safety, and quality are worker driven. Examples of worker-driven ergonomics program interventions are:

- Engineering controls
- Work practice controls such as job rotation
- Personal protective equipment (PPE) that is fit to the worker (gloves)
- Accommodation consistent with Americans with Disabilities Act (52 factors)
- Supervision to role model and recognize safe actions
- Training to build knowledge and safety competencies

### 20.3.1 Why

The goal of a validated job safety analysis is to create current and potential solutions that can be tailored to the individual(s), task requirements, and environment by time and severity. This goal includes quality and the continuous improvement of applications of controls. Job safety analysis that is quantified can be used as a comparative baseline in the workplace. Quality goals can then reevaluate JSAs to verify ergonomic solution effectiveness to determine if MSD hazards have been eliminated or reduced.

### 20.3.2 What

Job safety analysis documents the worker-driven risks for each job relative to the

- Person
- Method
- Materials
- Machines and equipment
- Instruments and tools
- Organization
- Environment

The importance of job safety analysis (JSA) in ergonomics is to create the optimum risk analysis of static and dynamic work methods. The job safety analysis documents both time and severity. The 37 job safety analysis factors of the Job Smart System ([www.jobsmartsystem.com](http://www.jobsmartsystem.com)) have been found to be the most comprehensive qualifiers of risk. The JSA factors are:

actions of work	quality knowledge
human factor systems	reasoning
internal human systems	safety knowledge
neuro musculoskeletal	sensory knowledge
senses	sensory demand
physical body parts	technology
biomechanical effort	time and effort
movement	working conditions
transitions	working environment
peak force	working equipment
ergonomics hazard probability	working guards
ergonomic hazard protection	work instruments
imitative	work tools
know-how	work machines
knowledge	work materials
language	work material handling
personal protective equipment	work material handling equipment
problem solving	work organization rules
project management	work recommendations
psychology knowledge	work risks



**Figure 20.1. Job safety analysis uses observation, interviews, and test equipment to validate job demands and job risk.**

### 20.3.3 Where to Start

- Ergonomic quality job safety analysis
- Prioritizing: selecting job titles for JSA factors involves the following:
  - reviewing loss control documentation
  - walk-through observational surveys of the work facilities to detect obvious risk factors
  - interviews with employees and supervisors to obtain the above information and other data not apparent in walk-through observations, such as time and work-load pressures, length of rest breaks, etc.
  - photo documentation of job demands to study postures
  - use of Job Smart System JSA to quantify job demands
  - use of the Job Smart System to validate risk factors by frequency and severity

### 20.3.4 Who Does the Analysis?

The Job Smart System combines the above procedures to provide the most formal and orderly procedure for screening by job title. Trained risk managers and safety

specialists/stakeholders who are familiar with job tasks and processes are best suited to qualify job demand data. In this way, quality is achieved. Using the professional judgment of people knowledgeable in their industry and the skill of trained JSA specialists is the best way to translate qualified data into quantifiable consistency.

#### 20.4 Prioritization of Interventions from Analysis of Data (MSD Related)

JSA integrates all risk factors for musculoskeletal disorders with all job demands and common safety hazards such as slips, trips, and falls. This is important. Jobs with risk factors for musculoskeletal disorders are automatically qualified and quantified by the Job Smart System. The intensive analysis to verify the existence of risk factors for musculoskeletal disorders is normative in the Job Smart System process:

- ❑ Job titles and workers with musculoskeletal disorders are identified by loss control runs.
- ❑ Complaints of musculoskeletal discomfort, established through questionnaires, are sorted in or out as work-related causes.
- ❑ Physical demands or risk factors of “perceived low- to high-risk jobs” even without medical or symptom data, are qualified and quantified to validate a strong risk implication for potential MSDs by time at a task and severity of risk analysis.

These three MSD scenarios justify a basis for setting priorities of JSA and undertaking risk factor analyses, which then prioritize control measures. Sorting to intervene looks like this:

- ❑ High risk:
  - Jobs associated with cases of musculoskeletal problems deserve the highest consideration in follow-up efforts to prioritize risk factors and implement control actions.
  - Jobs in which current cases have been identified should receive immediate attention, followed by those in which past records have noted a high incidence or severity of MSDs despite the lack of current cases.
  - Priority for job analysis and intervention should be given to those jobs in which most people are affected or in which work method changes are going to be taking place anyway.
- ❑ Moderate risk:
  - Jobs associated with worker complaints of fatigue and discomfort should be ranked next in deciding needs for follow-up job analysis and possible interventions.
- ❑ Low risk:
  - Finally, where JSAs suggest the presence of significant risk factors for musculoskeletal disorders.

NOTE: Ratings of high or extreme levels of risk factors, especially occurring in combination, may indicate a need for risk interventions. While appearing last in the priority order, taking steps to reduce apparent risk factors for musculoskeletal disorders is a preventive approach. Once the risks are documented, engineering controls can be one intervention or a set of controls that span solutions.

Engineering controls include matching a person's job competency expectations to workstation design; work methods design; materials, equipment, and machine; instruments and tools; organizational demands; in environments. Engineering controls are part of the ergonomic quality interventions that integrate accommodation, supervisions, and training on risks.

## 20.5 Success

### 20.5.1 Reduce the Physical Demands of the Work Tasks or Job

- Force
- Repetition
- Work postures
- Duration
- Vibration stress
- Temperature stress

### 20.5.2 Improve Materials and Objects Handled

- Size and shape
- Weight and weight distribution

### 20.5.3 Improve Equipment and Machines, Workstation Layout, and Space

- Work reaches
- Work heights
- Seating
- Floor surfaces
- Contact stress

### 20.5.4 Improve Instruments, Tools Used, and Objects Handled

- Size and shape
- Weight and weight distribution
- Handles and grasp surfaces
- Vibration

### 20.5.5 Work Organization

- Work-recovery cycles
- Work rate
- Task variability

### 20.5.6 Environmental Conditions

- Cold and heat
- Glare (as related to awkward postures)

## Human Factors to Be Considered Related to Job Competencies

### Knowledge

- Methods of work
- Materials
- Machines and equipment
- Instruments and tools
- Organization
- Environment

### Psychology

- Concentration
- Fatigue
- Emotions

### Biomechanical

- Balance, coordination
- Full range of motion
- Sitting
- Standing
- Head
- Upper extremities
- Lower extremities

### Safety

- OSHA
- ANSI
- CDC
- GHS
- EPA

### Strength and Stamina

- Lift, carry, place, transfer
- Materials, objects, people
- Weight
- Height, width, length

### Sensory

- Vision
- Hearing
- Olfactory
- Skin
- Taste
- Speech

### Quality

- ISO
- Six Sigma

The ergonomic importance of landscaping is primarily psychological, in that it is the official greeter of the workers when they arrive at work. Attractive landscaping can soften a mood and make an employee feel a part of an aesthetically pleasing environment. In this era of windowless environments, landscaping is an essential “escape.”

### 21.1 Ergonomic Design Benefits

- Improved safety
- Increased image

### 21.2 Consequences of Not Using Ergonomic Design

- Lost time
- Injury, illness

### 21.3 Gardening Considerations

- Garden in areas of non-polluted air, sun, and wind, with consideration of vegetation for shading, water management, and pesticide safety.
- Use proper drainage systems to prevent puddles or flooding.

### 21.4 Design of Outdoor Spaces

- Employee recreation areas should offer protection from the elements.
- In hot climates, a portion of the outdoor space should be protected by shade devices such as umbrellas, trellises, or trees.
- Walls or trees can provide protection from strong prevailing winds.
- Remote outdoor spaces or recreation areas should include canopies or similar protection from sudden rain showers.

### 21.5 Accessible Facilities

- Raised planters allow wheelchair users to see, touch, and smell flowers and plants. (Accessible restrooms, telephones, drinking fountains, and other public facilities should also be available within a convenient travel distance.)
- All walkways should have paved, smooth surfaces.
- Ramps or lifts should be provided at vertical level changes.
- Where outdoor dining is provided, aisles, tables, and chairs should meet the requirements for accessibility.

#### 21.5.1 Accessible Outdoor Spaces

- Terraces, gardens, pool decks, game areas, or other outdoor recreation spaces should be designed for the use and enjoyment of employees with restricted capabilities.  
—To help meet this objective, these outdoor spaces should be connected to the building’s accessible routes.

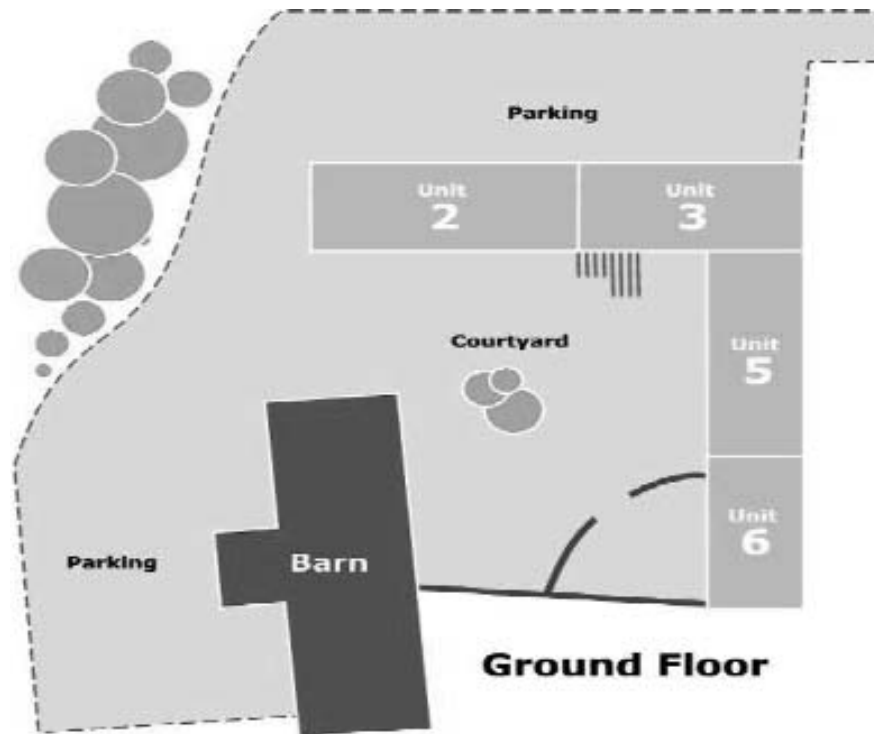

**Figure 21.1.** Landscaping integrates people into the beginning and rest stops of their workday.

### 21.5.2 Rest Areas

- ❑ Provide rest areas on long walkways that connect elements such as gardens, docks, golf courses, or tennis courts.
- ❑ Rest areas should provide protection from adverse elements and to take advantage of site amenities. These areas should include seating, trash receptacles, and lighting, where possible.
- ❑ Selected rest stops on long walks or trails should include facilities such as drinking fountains, canopies, and restrooms.

### 21.5.3 Benches

- ❑ Outdoor benches should have adequately designed backs and armrests.
  - The bench seat should be 21" to 18" from front to back and be approximately 18" above the ground.
  - The seat should decline slightly to the rear for comfort and to drain rainwater.
- ❑ Benches and trash receptacles should be located at least one foot from the edges of the paved walking surface.
- ❑ A three-foot-wide paved, open space is recommended adjacent to benches for wheelchair seating or strollers.

### 21.5.4 Signage

- ❑ Clear directional signage is important for orientation.
- ❑ Signs should be mounted at eye level, approximately five feet above the walkway.
- ❑ The signs and surface of the landscaped walkways should be illuminated for night use.

## Human Factors to Be Considered Related to Job Competencies

### Knowledge

- Methods of work
- Materials
- Machines and equipment
- Instruments and tools
- Organization
- Environment

### Psychology

- Concentration
- Fatigue
- Emotions

### Biomechanical

- Balance, coordination
- Full range of motion
- Sitting
- Standing
- Head
- Upper extremities
- Lower extremities

### Safety

- OSHA
- ANSI
- CDC
- GHS
- EPA

### Strength and Stamina

- Lift, carry, place, transfer
- Materials, objects, people
- Weight
- Height, width, length

### Sensory

- Vision
- Hearing
- Olfactory
- Skin
- Taste
- Speech

### Quality

- ISO
- Six Sigma

The importance of legibility of forms (in print and online) in ergonomics is to positively affect workers' productivity, safety, and quality. The visual quality of forms directly impacts the quality of communication and worker actions. The ergonomic worker focus is on the sensory competency of job demands that require forms to guide worker actions (work procedures, safety inspections, record keeping) on the job. Therefore, forms must be of *readable* text (labels on chemicals or medication) and available at the right site and time for safe actions to occur (MSDS forms). The ergonomic organizational focus is clear. All printed and interactive communication must be suited to the knowledge (English language, translations, or symbols) and *sensory competence* of workers. If safety initiatives and self-direction are to be encouraged, then printed forms need to be analyzed from an ergonomic perspective for visual and language clarity. Why do forms fail . . . and why do they succeed? They fail because of:

- Poor style
- Structural complexity, vocabulary, and syntax
- Lack of precision in the use of words
- Changes of meaning of words in particular contexts
- Heavy burden of new vocabulary or jargon, e.g., *nanotechnology*, *buckeyballs*
- Why forms succeed—readability checklist:
  - Print is at least 12 point and legible.
  - Illustrations assist comprehension.
  - Vocabulary is as simple as is permissible.
  - Level of conceptual difficulty and density is appropriate.
  - Syntax is familiar enough to facilitate reading.
  - Material is organized and indexed in a logical manner.
  - New vocabulary and jargon are defined.

## 22.1 Ergonomic Design Benefits

- Improved productivity
- Improved safety
- Improved quality
- Legal compliance

## 22.2 Consequences of Not Using Ergonomic Design

- Lost time
- Legal citation (Americans with Disabilities Act of 1990 can be evoked to EEOC if forms are not adapted for persons with disabilities)
- Injury, illness
- Disease
- Fatality
- Lost quality

### 22.3 Improving the Match of Worker Capabilities to Methods of Work

- ❑ Define the job by competencies for knowledge, psychology, biomechanics, sensory, strength and stamina, safety, and quality
- ❑ Validate job demands by intensity of the requirement (common sense to expert)
- ❑ Conduct job safety analysis
- ❑ Validate job demands by frequency and severity of risk
- ❑ Prescreen
  - industry-specific testing, job task simulation
  - prescreen workers at each stage of employment
  - first hired, lateral moves, promotion, return to work
- ❑ Checklist for screening sensory/disabilities related to forms
  - Integrate the knowledge, psychological, safety, and quality competencies of business requirements with the physical and sensory demands.
  - Physical: Coordinate and cross-train workers on where forms are located for ease and speed of access.
  - Cross-training could include order processing from bar code summary forms to labels to computer screen summaries to transport tickets and forms.
  - Sensory: Set up work areas to increase eye-hand and all sensory coordination (sight, hearing, touch, smell, taste).

### 22.4 Improving the Methods of Work on Paper or Online

- ❑ Forms must be of *readable* text (labels on chemicals or medication).
- ❑ Available at the right site (bulletin boards, accessible online files).
- ❑ Timely safe actions to occur (MSDS forms that are up to date).

### 22.5 Improving the Materials of Work

- ❑ Integrate the knowledge competencies of business requirements with the physical and sensory demands.
- ❑ Readability: This is the combination of reader factors and textual factors. Keep the potential reader in mind. Workers may be less able readers and learn best with the fewest number of words.
  - Braille is a language readable with sensation/touch.
- ❑ Reading ability varies according to task, so take advantage of situations where the workers are already familiar with the content of a work situation.
- ❑ Motivational factors on how much workers will read tends to be overestimated; even if the content is related to pay raises, it can still cause reading difficulties.
- ❑ Check your forms for readability:
  - legibility of print
  - illustrations: use pictures; they speak clearly
  - vocabulary
  - conceptual difficulty
  - syntax
  - organization

## 22.6 Improving the Equipment and Machines of Work

- ❑ Scale the sensory access points for workers to alerts that will be seen, such as work area-specific bulletin boards.
- ❑ Use preventive maintenance forms for equipment and machines to track timelines.

## 22.7 Improving the Instruments and Tools of Work

- ❑ Documents are a tool of work. Test them and edit more than once.

## 22.8 Improving the Organization of Work

- ❑ Create organizationally appropriate forms. You must match the subject and text of your forms. Then evaluate whether your form:
  - has a logical scope and sequence
  - reflects recent developments in regulations, standards such as Global Harmonizing Symbols
  - requires interpretation
  - has a conceptual framework that gives it direction and purpose while achieving a consistent perspective
  - has a content based on identifiable and acceptable assumptions and factual information relevant to any concepts examined
  - is consistent in the use of terminology and concepts without ambiguities, vague terms, and unclear meanings
  - has a defensible scheme for the selection of material
  - attempts to focus on or identify problems and hypotheses that can serve to stimulate worker thought and inquiry
  - encourages workers to question various observations and related interpretations of reported phenomena
  - promotes the creativity of work solutions
  - deals freely with controversial issues and where feasible, identifies all points of view; if one point of view is preferred, makes clear on what grounds the conclusion was reached
  - has definitive, detailed, and annotated bibliographies, with fully identified statistical data sources.
- ❑ Use digitized plant networking to develop accurate times for product or load transfers being routed.

## 22.9 Improving the Environment of Work

- ❑ Integrate accessibility, adaptability, lighting, passages, and signage into safety components of legibility of forms.
- ❑ If a form has the potential to be damaged by weather, protect it in plastic.

## Human Factors to Be Considered Related to Job Competencies

### Knowledge

- Methods of work
- Materials
- Machines and equipment
- Instruments and tools
- Organization
- Environment

### Psychology

- Concentration
- Fatigue
- Emotions

### Biomechanical

- Balance, coordination
- Full range of motion
- Sitting
- Standing
- Head
- Upper extremities
- Lower extremities

### Safety

- OSHA
- ANSI
- CDC
- GHS
- EPA

### Strength and Stamina

- Lift, carry, place, transfer
- Materials, objects, people
- Weight
- Height, width, length

### Sensory

- Vision
- Hearing
- Olfactory
- Skin
- Taste
- Speech

### Quality

- ISO
- Six Sigma

Lighting strategy is most frequently part of an architectural plan of workplace form and function. Over time, lighting is often on the forefront of the cost reduction attack (e.g., saving money and ozone by cutting lights). Yet, lighting to task is one of the most important factors in ergonomics. Light affects the ability of employees to see, particularly as they age. Light attracts people to space while darkness deters them from it. For example, people will linger in an area that has higher light levels (people talking in passageways) and move more quickly through dark areas (storage).

Light also affects the way people feel. Some people need more light to eliminate the depression of seasonal affective disorder. By manipulation of lighting to forms, textures, color renderings, and specifically to the needs of a task, lighting can evoke many different and desired responses from the employee. For example, lighting in stockrooms should allow for the easy reading of labels and identification of stored items. A lighting system should be developed that is a general pattern system and a focal system and that permits switching and dimming controls to specific areas. Lighting should always be an integral part of an ergonomic design to enhance visual acuity.

### 23.1 Ergonomic Design Benefits

- Improved safety
- Legal compliance

### 23.2 Consequences of Not Using Ergonomic Design

- Lost time
- Injury, illness
- Disease
- Fatality
- Lost quality
- Increased cost
- Legal citation

### 23.3 Suggested Lighting

- Parabolic louvers to eliminate screen reflection
- Dimmers for task-ambient levels
- Daylight sensors
- Pigtail or tether systems for relocatability
- Radio frequency or infrared remote controllers
- Uplighting
- Covelighting/ceiling configurations
- Daylight interface with electric lighting
- Wall, floor, and furniture task and ambient fixtures
- Two-adjustable-arm, high-efficiency task lamps
- Toplighting with high-efficiency reflectors and lenses
- Sidelighting with light shelves
- Sloped ceilings

- Diffuse lighting
- Prismatic windows
- View of content

### **23.4 Fluorescent Lighting**

- The utilization of innovative fluorescent lighting in commercial applications includes the integral compact fluorescent and improved four-foot T-8 and T-10 fluorescent lamps.
- The majority of standard T-12-diameter fluorescent lamps available today (and those that do cost as much as the best T-8 or T-10 diameter systems) will not meet these standards.
- New T-12 lamps that meet these requirements will be developed; however, the price will be high enough that switching to T-8 lamp technology will most often not be cost-effective.
- New standards for lamp efficacy will also be required for incandescent reflector lamps, effective three years from the date of passage.

### **23.5 Changes in the Way of Doing Business**

Over the past decade, people have experienced a change in the way they do business in a number of ways.

- The office environment, which used to be paperwork-oriented, has changed into an electronically dominated space containing computers, cellular telephones, faxes, and other modern equipment. This metamorphosis has permanently changed the nature of office work and, with it, the office environment.
- The way our retail stores market their products has changed, going from a mass-merchandising approach to more successful visual merchandising strategies.
- In industry, we are moving away from labor-intensive businesses toward those dominated by automated equipment and systems.
- All these changes in society and business have affected the way we use and perceive lighting and have resulted in different demands on modern lighting installations.

### **23.6 Energy Conservation**

- One of today's primary requirements for lighting is energy conservation. Lighting consumes approximately 25% of the total electricity used in the business world and is a natural target for the energy and environmental conservation measures encouraged by government, utilities, and other special interest groups.
- Light sources have become more energy-efficient, more compact, and better designed for quality visual characteristics.

#### **23.6.1 Recent Developments in Lighting**

- Compact fluorescent lamps to replace inefficient light sources like incandescent lamps without sacrificing color rendering and light output.

- ❑ New, innovative fluorescent systems consisting of reduced diameter four-foot lamps, high-efficiency light sources, electronic ballasts, and dimming controls that allow for lower energy consumption while delivering higher quality lighting to commercial spaces.
- ❑ According to the Environmental Protection Agency (EPA), if all businesses utilized high-efficiency lighting techniques, 11% of the electricity used would be saved (totaling \$18.6 billion annually at today's cost).
- ❑ In addition to energy savings, there would be other environmental benefits, such as a 5% reduction in the atmospheric levels of sulfur dioxide (the primary cause of acid rain) and carbon dioxide, which is believed to contribute to global climatic changes via the greenhouse effect.
- ❑ Further reductions in the consumption of electricity would curtail the building of new power plants (another benefit to an already overtaxed environment).

### 23.7 Lighting Considerations

- ❑ Account for the following lighting considerations:
  - prismatic glass
  - interior light diffusers/reflectors
  - frit glazing, inverted mini blinds
  - light pipes, fiber optics
  - interfacing with electric lighting configuration and control
  - spatial orientation, depth, ceiling configuration, layout
  - specifications for viewing cone, view, content, and clarity
- ❑ Each development in electric lighting requires parallel developments in the management of daylight glare and brightness contrast, demonstrated so far in only a few innovative projects.

### 23.8 Lighting Environments

- ❑ Light quantity and quality play a considerable role in determining office worker productivity.
- ❑ Natural light through windows should be combined with interior lighting.
- ❑ A flexible combination of indirect and task lighting should utilize the space distribution system, as opposed to simply using the traditional ceiling system.

### 23.9 Natural Lighting

- ❑ Use more effective natural/electric light balancing in order to reduce visual strain from long hours in front of computer screens.
- ❑ Combining low ambient lighting from daylight and electric light sources with task lighting, locally controlled for individual preferences, time of day, and activity.

### 23.10 Innovations

Lighting system innovations include:

- continuous dimming fixtures
- individually switched (on/off) fixture
- easily relocatable tether or pigtail fixtures
- shielded fixtures in which neither the image of the bulb nor the lens is reflected on the work surface or the computer screen

## Human Factors to Be Considered Related to Job Competencies

### Knowledge

- Methods of work
- Materials
- Machines and equipment
- Instruments and tools
- Organization
- Environment

### Psychology

- Concentration
- Fatigue
- Emotions

### Biomechanical

- Balance, coordination
- Full range of motion
- Sitting
- Standing
- Head
- Upper extremities
- Lower extremities

### Safety

- OSHA
- ANSI
- CDC
- GHS
- EPA

### Strength and Stamina

- Lift, carry, place, transfer
- Materials, objects, people
- Weight
- Height, width, length

### Sensory

- Vision
- Hearing
- Olfactory
- Skin
- Taste
- Speech

### Quality

- ISO
- Six Sigma

The importance of ergonomics and external maintenance is that working outdoors can expose workers to the extreme environmental conditions of cold and heat stress. Both of these conditions can affect the productivity, safety, and quality of worker performance. Every year, over 2,800 people are treated for work-related environmental stress of heat stroke and hypothermia.

Working in cold environments requires ergonomic interventions to reduce the risk of hypothermia and frostbite. Cold temperatures refer to exposure to excessive cold (< 32°F with wind chill) while performing work tasks. Cold temperatures can reduce the dexterity and sensitivity of the hands. Cold temperatures, for example, cause the worker to apply more grip force to hold hand tools and objects. Prolonged contact with cold surfaces (handling cold tools or meat) can impair dexterity and induce numbness. Cold is a problem when it is present with other risk factors and is especially problematic when it is present with vibration exposure.

Heat stress includes a series of conditions in which the body is under stress from overheating. It can include heat cramps, heat exhaustion, heat rash, or heat stroke. Each produces bodily symptoms that can range from profuse sweating to dizziness to cessation of sweating and collapse. High temperatures, heavy workloads, the type of clothing being worn, and so on can induce heat stress.

Ergonomics for both cold (hypothermia) and heat stress (dehydration) focuses on risk reduction to the brain and the body's internal organs. Keeping the worker comfortable in extreme conditions ensures not just productivity but in some cases, survivability. For both cold and heat stress, it is important to know the signs of stress in external maintenance conditions and the proper ergonomic interventions to avoid it.

### 24.1 Ergonomic Design Benefits

- Improved productivity
- Improved safety
- Improved quality
- Legal compliance

### 24.2 Consequences of Not Using Ergonomic Design

- Lost time
- Legal citation
- Injury, illness
- Disease
- Fatality
- Lost quality

### 24.3 Improving the Match of Worker Capabilities to Methods of Work

- Define the job by competencies for knowledge, psychology, biomechanics, sensory, strength and stamina, safety, and quality.
- Validate job demands by intensity of the requirement (common sense to expert).
- Conduct job safety analysis.
- Validate by frequency and severity of risk.

- ❑ Prescreen workers at each stage of employment.
- ❑ Industry-specific testing, job task simulation.
- ❑ First hired, lateral moves, promotion, return to work.
- ❑ Special considerations:
  - Some employees are more likely to have heat disorders than others. Younger employees and those more physically fit are often less likely to have problems. Employees with heart, lung, or kidney disease, employees with diabetes, and those on medications are more likely to experience heat stress problems. Diet pills, sedatives, tranquilizers, caffeinated drinks, and excessive alcohol consumption can all exacerbate heat stress effects.
  - It often takes two to three weeks for employees to become acclimated to a hot environment. This acclimation can subsequently be lost in only a few days away from the heat. Thus, employees should be especially cautious about heat stress after coming back from a vacation, when beginning a new job, or after the season's first heat wave. In short, precautions should be taken anytime there are elevated temperatures (approaching 90°F) and the job is physically demanding.

#### 24.4 Improving the Methods of Work

- ❑ Coordinate and cross-train workers on static and dynamic postures that use neutral posture to reduce occupational stress.
  - Mitigate the effects of static postures.
  - Maintain dynamic work with cross-training.
- ❑ Develop ergonomic guidelines (e.g., for shoveling).
- ❑ Mitigate health risks with the proper PPE, rest breaks, and rotation.
- ❑ Skin cancers.
- ❑ Dehydration.
- ❑ Physical: Accommodate outdoor exposure to full sun, high temperatures (> 90°F), high humidity, and high wind (hurricane) conditions.
- ❑ *Heat stress*: It is important to know the signs of heat stress and the proper first aid to treat it:
  - IMPORTANT: The victim often overlooks the signs of heat stress. The employee may at first be confused or unable to concentrate, followed by more severe symptoms such as fainting and/or collapse. If heat stress symptoms occur, move the employee to a cool, shaded area, give him or her water, and immediately contact the supervisor.
  - Other heat stress factors are also very important. In addition to temperature, increased relative humidity, decreased air movement, or lack of shading from direct heat (radiant temperature) will all increase the potential for heat stress.
- ❑ *Cold stress*: Static work reduces blood flow to muscles and other tissues. This may interfere with the ability of muscles and other tissues to recover from the effects of static loading. Exposure to cold temperatures also causes reduction in manual dexterity and feeling. It is crucial to understand how to protect the body from excessive exposure to cold conditions. The ambient temperature and duration of exposure to cold are keys to determining the level of risk from exposure. The methods of work that have risk can be reduced by following the guidelines below:

- Layering: Proper layering using lightweight and comfortable fabrics traps the air warmed by the body, while letting moisture vapor from perspiration be conducted away from the skin.
- Wicking: The first layer for cold weather exposure should keep you warm and dry. The best materials for long underwear are those that “wick” wetness away from the skin quickly and effectively. Synthetic fibers dry quickly and pull perspiration vapor away from the skin toward the insulation layer, where it can evaporate.
- Insulation: Once again, warmth and dryness are crucial factors. Insulating layers may need to be added if the activity level tapers off. The best insulators (wool, goose down) will trap warm air but still provide ventilation. Clothing should be comfortable and lightweight, durable and windproof.
- The shell: Outerwear should be appropriate for the activity. Jackets and pants must allow perspiration vapor to vent while blocking wind and rain. The material must reduce heat loss and assist the rest of the layers in providing dryness and comfort.
- Exposure: Cover head and hands in addition to layering; it is very important that the head, hands, and feet are protected from the damp and cold.
- Hats: The head and neck lose heat faster than any other part of the body. Covering the head is critical because, unlike the hands and feet, the blood supply does not become constricted in the cold. This is why body heat escapes through the head more readily than through the hands or feet.
- Gloves: When exposed to the cold, the body limits the amount of blood pumped to the extremities in order to preserve heat within the vital organs. That’s why hands and feet are the first things to get cold—they’re being sacrificed, in a sense, for the more important body parts. Provide gloves that are breathable and waterproof.
- Footwear: Feet can get cold quickly and allow heat to escape. The feet generally can pump a full cup of perspiration over the course of an active day. Footwear should be durable, waterproof, and breathable, and should include synthetic fiber or wool socks with a thin pair of wicking socks.

## 24.5 Improving the Materials of Work

- Materials should not conflict with worker dexterity in either heat or cold stress conditions.
- Reduce the dimension of materials that can cause overexertion.
- Evaluate
  - expected load (weight, size, shape)
  - frequency of use
  - distances to cover
  - work area characteristics (e.g., type of terrain)
- PPE should not hold heat or increase moisture in confined space work where extremes of heat and cold exist.

## 24.6 Improving the Equipment and Machines of Work

- ❑ Use preventive maintenance of equipment and machines to reduce force needed to do the work.
- ❑ Match just-in-time processing with consideration to worker schedules in extreme environmental conditions.
- ❑ Start work early in heat stress environment. Rest during noon hours. Resume late afternoon to past dusk.
- ❑ Reduce overtime demands.
- ❑ Create solutions of indoor environments as cool and warm spots in temperature stress conditions.

## 24.7 Improving the Instruments and Tools of Work

- ❑ Purchase ergonomic tools and use ergonomic setup guidelines to meet task demands in heat and cold stress conditions.
- ❑ Cold temperature adds to the amount of force necessary to perform repetitive motions and increases the perception of stiffness of the joints and tissues in the body. Exposure to cold temperatures triggers the body to redirect blood flow from the extremities (hands, feet, and ears) in order to conserve body heat. When the blood supply to the hands is diminished, the manual dexterity and tactile sensitivity of the fingers are reduced. Employees compensate by applying more force to the muscles in the hands and fingers in order to complete the motions. The effects of any or all of the risk factors discussed can be exacerbated if the employee is exposed to cold while operating the tool. The cold temperatures can be due to the workplace environment (using a chain saw in the winter) or due to air blowing from the power tool across the operator's hand. When cold air blows across the hands, the fingers get cold and they are less dexterous. The reduction in dexterity occurs because blood flow is reduced in the fingers, blood flow becomes constricted, and the tissue becomes stiff. This occurs when
  - using a chain saw in the winter to remove debris from road
  - using a knife on a boat to process catfish fillets
  - using a socket wrench to change out equipment on a roof
  - using a shovel to move snow
- ❑ Exposure to cold temperatures also reduces the ability of tissues to recover from repetitive exertions. The reduction in blood flow reduces the delivery of oxygen and energy to tissues, and the removal of heat and waste products. This reduction in blood flow can also lead to pain and injury.
- ❑ Vibration reduces blood flow to the affected tissues. Vibration has a synergistic effect on the loss of blood flow in the presence of cold temperatures. The effect is present in the extremities because the body reacts to cold temperatures by shunting blood away from the extremities to preserve body heat. This occurs when
  - driving a fork truck on the dock
  - using vibrating etching machines and tooling

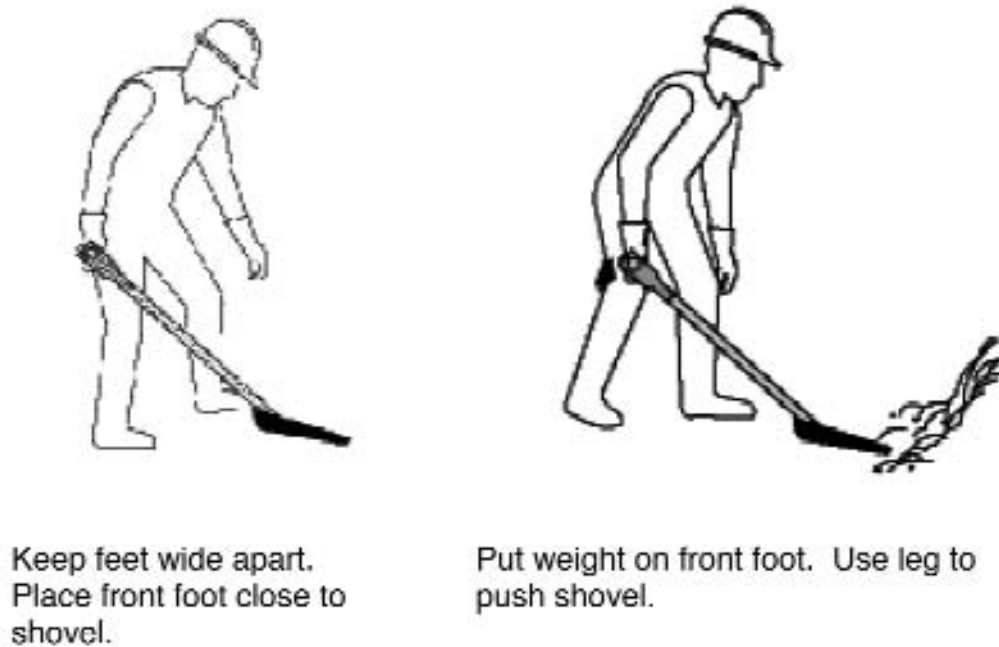

**Figure 24.1.** Workers using shovels safely.

## 24.8 Improving the Organization of Work

- Create cold stress and heat stress supervision guidelines.
- Allow time for employees to adjust to hot and cold jobs when possible. It often takes two to three weeks for an employee to become acclimated to a hot or cold environment.
- Adjust the work schedule, if possible. Assign heavier work on cooler days or during the cooler part or warmer part of the day.
- Avoid placing “high-risk” employees in hot work environments for extended time periods. Realize individual employees vary in their tolerance to heat stress conditions.
- Reduce, spread out, or cross-train on workload.
- Increase the use of equipment on hot and cold days to reduce physical labor.
- Establish a schedule for work and rest periods.
- Train workers to recognize signs and symptoms of heat and/or cold stress disorders.
- Supervisors should be prepared to give first aid if necessary.
- Choose appropriate first responder employees.

## 24.9 Improving the Environment of Work

- ❑ Integrate accessibility, adaptability, density, design of space, lighting, passages, and personal protective equipment into safety components of external maintenance.
- ❑ Working in cold environments requires the environment of work to have safe warming spots where the body can recover from the awkward postures, force, and duration of cold.
- ❑ Working in heat extreme environments: Cool-off areas are critical to reducing heat stress factors. These areas must allow the body to recover in normal temperatures with reduction in temperature, relative humidity, increased air movement, and/or shading from direct heat (radiant temperature). These cooling areas will reduce the effect and the potential for heat stress.

## Human Factors to Be Considered Related to Job Competencies

### Knowledge

- Methods of work
- Materials
- Machines and equipment
- Instruments and tools
- Organization
- Environment

### Psychology

- Concentration
- Fatigue
- Emotions

### Biomechanical

- Balance, coordination
- Full range of motion
- Sitting
- Standing
- Head
- Upper extremities
- Lower extremities

### Safety

- OSHA
- ANSI
- CDC
- GHS
- EPA

### Strength and Stamina

- Lift, carry, place, transfer
- Materials, objects, people
- Weight
- Height, width, length

### Sensory

- Vision
- Hearing
- Olfactory
- Skin
- Taste
- Speech

### Quality

- ISO
- Six Sigma

The ergonomic importance of internal maintenance is to maintain the equipment and the environment in a manner that promotes safety and equipment efficiency. A preventive maintenance program should be developed that fulfills the needs of the organization to prevent injury and repair costs. Workers need to be part of the maintenance team within their areas in order to promote “ownership” of their physical and intellectual capacities. Work orders on failed equipment should have a routing system and an expected timeline for completion. The machines, equipment, tools, and workplace environment should permit satisfactory levels of worker performance and provide a safe work environment.

### 25.1 Ergonomic Design Benefits

- Improved safety
- Legal compliance

### 25.2 Consequences of Not Using Ergonomic Design

- Lost time
- Injury, illness
- Disease
- Fatality
- Lost quality
- Increased cost
- Legal citation

### 25.3 Maintenance Responsibility

- Proper maintenance yields a productivity improvement of 10%–15% for most organizations. Improvements can occur in both cost reduction and quality.

### 25.4 How to Reduce Maintenance Costs and Improve Quality

Develop illustrated training manuals to guide staff in specific actions (with considerations for cultural diversity); for example:

- A. Spray window fully.
- B. Wait 30 seconds.
- C. Wipe clean with paper towel.

- Write clear job descriptions for all workers. Each duty should be outlined.
- Use positive titles such as environmental service worker, rather than negative titles such as janitor.
- Train workers properly to ensure the quality of the routines and safety of all employees. For example, each worker assigned to an area containing carpets should be trained and equipped to remove stains using stain-removal kits. Many times, the successful removal of carpet stains depends solely on how quickly the worker attempts to remove them.

Task	Frequency of Service Computer Rooms	Copy Rooms, Duplicating, Graphics, Etc.
Police litter	Daily	Daily
Empty and spot-clean trash receptacles	Daily	Daily
Empty and spot-clean ash receptacles	Daily	Daily
Replace soiled or torn liners	Daily	Daily
Clean chalk and marker boards	Weekly	Weekly
Provide clean erasers	Daily	Daily
Dust horizontal building and furniture surfaces	Daily	Daily
Dust vertical building and furniture surfaces	Every two weeks	Every two weeks
Polish unsealed wood furniture	As needed	As needed
Spot-clean walls, doors, furnishings, and glass	Daily	Daily
Completely clean entrance door glass	Weekly	Weekly
Clean and disinfect water fountains	Daily	Daily
Spot-clean carpet stains	Daily	Daily
Partially vacuum (traffic patterns, obvious soil)	Daily	Daily
Completely vacuum	Weekly	Weekly
Dust-mop or sweep non-carpeted floors	Daily	Daily
Spot-mop non-carpeted floors	Daily	Daily
Damp-mop non-carpeted floors	Every two weeks	Every two weeks
Wet-clean non-carpeted floors	As needed	As needed
Spray-buff metal-link finished floors	As needed	Every two weeks
Refill dispensers	As needed	As needed
Disinfect furniture, fixtures, partitions, and walls	As needed	As needed
Clean and disinfect sinks, toilets, urinals, and showers	As needed	As needed
Damp-mop and disinfect non-carpeted floors	As needed	As needed
Descale toilets and urinals	As needed	As needed
Clean floor drains	As needed	As needed
Replace furniture in proper locations	Daily	Daily

**Figure 25.1. Sample routine maintenance schedule.**

- ❑ Assign repetitive work (performed more often than monthly) on an area-complete basis.
  - This work should be assigned to one person who should perform all routine tasks within the assigned area.
  - The work should be measured to ensure a fair assignment and reasonable expectations. This will provide the opportunity to evaluate individual performance and to recognize and reward quality effort.
- ❑ Supplement the worker performing the routine work with special project teams.
  - The project team should perform infrequent labor-intensive tasks, such as stripping and refinishing floors, carpet extraction, window washing, etc.
  - The project team should be well trained and utilize special equipment not required by regular workers.

- ❑ Provide a relief staff to perform the work of absent workers.
  - Ensure that each assignment is performed completely as specified; standardize the service to the “customer” and help maintain the desired level of quality.
  - Eliminate the practice of regularly pulling workers from their assigned area to perform the work of an absent worker. This will improve the worker’s morale.
- ❑ Eliminate all products containing a “poison” or “flammable” label. There are many products that do not have these characteristics that will do the job.
- ❑ Avoid standard specialty products such as scouring powder, ammonia, bleach, steel wool, pine oil, etc., as a number of modern cleaning materials cost little more, do not harm the user or the surface on which they are used, and do a much better job.
- ❑ Let the custodial office be an example for others.
  - Maintain a neat and organized desk, remove unprofessional materials and pictures from the walls, and have all equipment and reference material readily available.
  - The custodial office should send a message to everyone that the department is well organized and efficient.

## Human Factors to Be Considered Related to Job Competencies

### Knowledge

- Methods of work
- Materials
- Machines and equipment
- Instruments and tools
- Organization
- Environment

### Psychology

- Concentration
- Fatigue
- Emotions

### Biomechanical

- Balance, coordination
- Full range of motion
- Sitting
- Standing
- Head
- Upper extremities
- Lower extremities

### Safety

- OSHA
- ANSI
- CDC
- GHS
- EPA

### Strength and Stamina

- Lift, carry, place, transfer
- Materials, objects, people
- Weight
- Height, width, length

### Sensory

- Vision
- Hearing
- Olfactory
- Skin
- Taste
- Speech

### Quality

- ISO
- Six Sigma

The importance of ergonomics and material handling is that material handling is associated with the most common cause of occupational fatigue, illness, and injury to shoulders, knees, and backs. Material handling is defined as biomechanical job competencies that require a person to lift, lower, push, pull, carry, throw, move, restrain, or hold any animate (e.g., a person) or inanimate object. Material handling becomes hazardous when awkward posture, repetition, duration, temperature, or vibration extremes combine to force workers to extend themselves beyond their biomechanical and sensory competencies.

A worker can sustain a back injury from a single episode such as lifting too heavy a load, slipping and falling, or receiving a blow to the back. However, most often it is not the single episode that causes back, shoulder, or knee injury; it is the repetition, as in manual handling, that contributes most to the occurrence of injuries. Performing tasks continually, even at a moderate intensity, will cause mechanical stress to accumulate in the worker's back, increasing the likelihood of injury. Eventually, even a mild effort can result in back injury and disabling back pain. Recovery from back injuries can take a long time and further injury may occur, making the problem worse.

### 26.1 Ergonomic Design Benefits

- Improved productivity
- Improved safety
- Improved quality
- Legal compliance

### 26.2 Consequences of Not Using Ergonomic Design

- Lost time
- Legal citation
- Injury, illness
- Disease
- Fatality
- Lost quality

### 26.3 Improving the Match of Worker Capabilities to Methods of Work

- Define the job by competencies for knowledge, psychology, biomechanics, sensory, strength and stamina, safety, and quality.
- Validate job demands by frequency and severity of risk.
- Job safety analysis.
- Prescreen workers at each stage of employment.
- First hired, lateral moves, promotion, return to work, body weight and strength.
- Job safety analysis factors may dictate screening for relative competence to take safe actions.
- Height of force required.
- Application and direction of force.

- ❑ Application and distance of force.
- ❑ Application from the body posture (bending forward or leaning backward).
- ❑ Friction coefficient (amount of friction or grip between floor and shoes).
- ❑ Duration and distance of push or pull.

#### 26.4 Improving the Methods of Work

- ❑ Integrate the knowledge, psychological, safety, and quality competencies of business requirements with the physical and sensory demands.
- ❑ Physical: Coordinate and cross-train workers on static and dynamic postures to reduce occupational stress of:
  - poor lifting techniques (lifting too fast, too often, or too long)
  - lifting with back bent or while twisting or reaching too far
  - lifting while sitting or kneeling
  - having to move material over long distances
  - not taking appropriate rest breaks
  - insufficient recovery time
  - job demand with a combination of handling tasks (e.g., lifting, carrying, and lowering)
- ❑ Cross-training could include safe lift, carry, and place techniques with housekeeping, interplant transfer, and waste management.
- ❑ Create safe action protocols for
  - using manual carts and trucks
  - sliding objects such as cartons on flat surfaces (tables, floors, etc.)
  - operating tools and controls
  - opening and closing doors
  - wrapping or enclosing objects in packaging materials too heavy for the task
  - located too high or low for a safe lift
  - too big or may have a shape that makes it hard to handle
  - wet, slippery, or have sharp edges that makes it hard to grasp
  - unstable or can shift its center of gravity because contains material that can flow (e.g., a partially filled drum or concrete in a wheelbarrow)
  - too big to let a person see where he or she is putting the feet to maintain stability
- ❑ Sensory: Set up work carts to increase eye-hand and all sensory coordination (sight, hearing, touch, smell, taste).

#### 26.5 Improving the Materials of Work

- ❑ Have a material handling program that plans and manages the orderly flow of work and movement of materials from point of entry to exit.
- ❑ Integrate the knowledge competencies of safe actions when using material handling equipment.
- ❑ Coordinate and cross-train workers on the weight and dimensions and properties of materials and equipment that could cause risk:

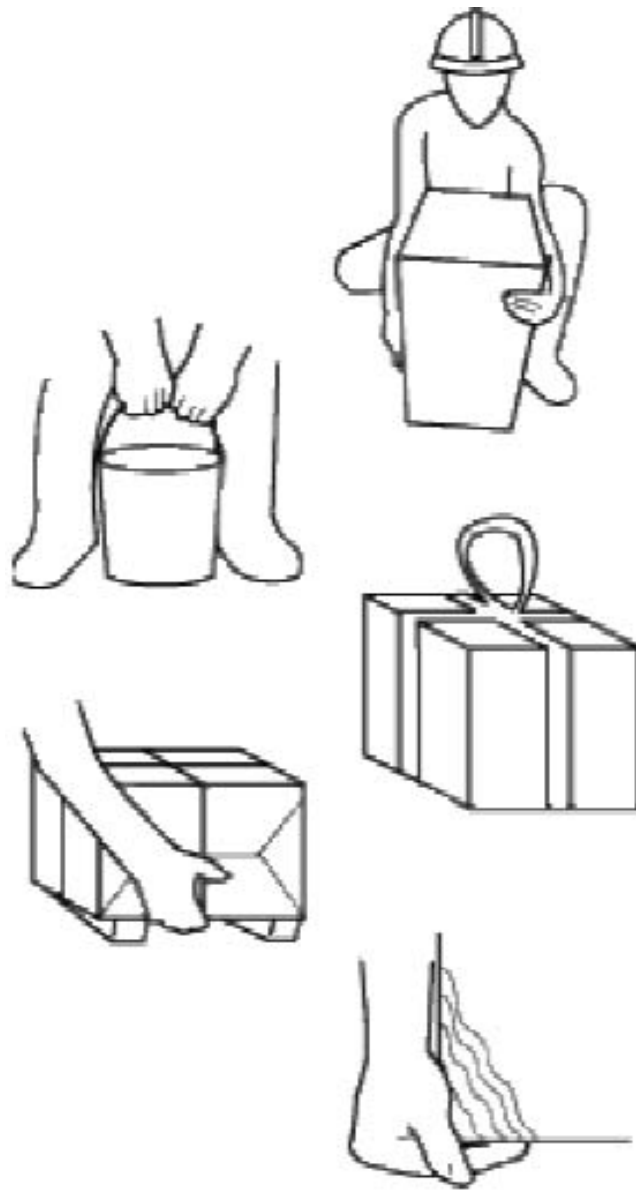

Figure 26.1. Material handling: Motions.

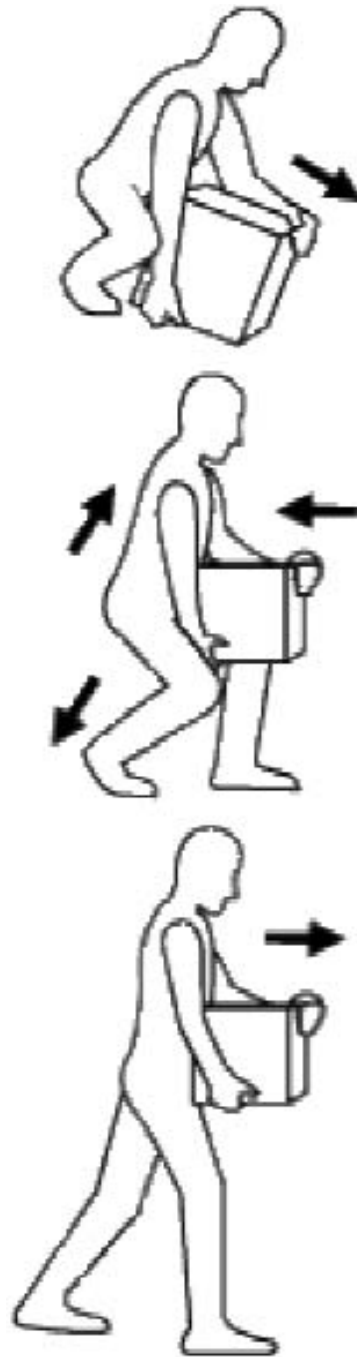

Figure 26.2. Material handling: Safe lifting.

organic	Hoyer Lift
solid	crane
fluid	drum handler
composite	dolly
chemical	hand truck
fabric	conveyor
metal	pallet jack
mineral	sling
nylon	stock truck
nano	robot
plastic	stacker
rubber	hoist
synthetic	pulley
wood	cart

- Physical and Sensory: Create solutions that alert workers to the specific risk of a material handling task by weight and dimensions of height, length, and width.
- Sensory: Very important that safe passage with materials include the person's competence to see and hear alert signals of risk, such as forklift in a passageway or ice on a dock.

## 26.6 Improving the Equipment and Machines of Work

- Control the access points between products, people, and workers with materials to reduce awkward postures.
- Tripping over loose objects on floors, stairs, and platforms.
- Being hit by falling objects.
- Slipping on greasy, wet, or dirty surfaces.
- Striking against projecting, poorly stacked items, or misplaced material.
- Cutting, puncturing, or tearing the skin of hands or other parts of the body on projecting nails, wire, or steel strapping.
- Use preventive maintenance of equipment and machines to reduce force needed to work with material handling equipment.
- Match just-in-time processing with consideration to worker schedules. Reduce overtime demands.
- Create solutions from simple stock locator solutions to advanced real-time system-directed solutions that would be integrated with automated materials handling equipment and new innovations, such as voice recognition technology.

## 26.7 Improving the Instruments and Tools of Work

- Purchase ergonomic tools for job tasks that include opening (knives) or closing cartons (tape dispensers).
- Set up material handling carts that must be weighed with wheels to aid ease of movement.
- Match personal protective equipment to the material handling tasks.
- Use adjustable supports or suspenders to support the job tasks related to material handling and tool use.

## 26.8 Improving the Organization of Work

- Use software to design work areas and create dynamic routing that optimizes the flow of materials to critical and remote areas.
- Reduce manual material handling tasks to increase the ease and flow of materials.
- Use of manual carts and trucks
- When sliding is occurring, e.g., sliding objects such as cartons on flat surfaces (tables, floors, etc.)
- Operating tools and controls
- Opening and closing doors using the equipment with force
- Wrapping or enclosing objects in packaging materials

## 26.9 Improving the Environment of Work

- Integrate accessibility, adaptability, density, and design of space, housekeeping, lighting, and passages into safety components of material handling.
- Design the layout of the workplace to reduce the risk for injury. For example, shelving that is too deep, too high, or too low causes unnecessary bending or stretching.
- Density of space to move freely decreases the need for twisting and bending. Unsuitable dimensions of benches, tables, and other furniture force the worker to perform in awkward positions that add stress to the musculoskeletal system.
- Similar stressful body movements occur where work areas are overcrowded with people or equipment.
- The environmental conditions of work can also contribute to risk, for example
  - walking surfaces that are uneven
  - sloping, wet, icy, slippery surfaces
  - unsteady floors that vibrate from machines
  - differences in floor levels or walking surfaces
  - poor housekeeping that causes slip, trip, and fall hazards
  - inadequate lighting
  - cold or very hot and humid working conditions
  - strong wind or gusty conditions
  - working at high pace
  - movement restricted because of clothing or personal protective equipment
  - floor space is small
  - posture is constrained
- Integrate the material-handling program with housekeeping inspections.

## Human Factors to Be Considered Related to Job Competencies

### Knowledge

- Methods of work
- Materials
- Machines and equipment
- Instruments and tools
- Organization
- Environment

### Psychology

- Concentration
- Fatigue
- Emotions

### Biomechanical

- Balance, coordination
- Full range of motion
- Sitting
- Standing
- Head
- Upper extremities
- Lower extremities

### Safety

- OSHA
- ANSI
- CDC
- GHS
- EPA

### Strength and Stamina

- Lift, carry, place, transfer
- Materials, objects, people
- Weight
- Height, width, length

### Sensory

- Vision
- Hearing
- Olfactory
- Skin
- Taste
- Speech

### Quality

- ISO
- Six Sigma

In the new millennium, material resource conservation is the responsibility of every organization and every worker. Many organizations are subscribing to the International Standards Organization (ISO) 9000 criteria. Most materials that are conserved for reuse require special handling procedures. Some materials may be set aside for recycling, while others may be “contained as contaminants.” In any case, material resource conservation becomes a part of the production process in many facilities and has ergonomic implications because it often involves “material handling” in special ways. Material resource conservation may involve workers in stresses (such as biomechanically lifting or moving) or sensorially (by exposure to minute or large amounts of chemicals). An ergonomic review of how materials are managed for conservation is often overlooked as a potential for risk reduction.

### 27.1 Ergonomic Design Benefits

- Improved safety
- Legal compliance

### 27.2 Consequences of Not Using Ergonomic Design

- Lost time
- Injury, illness
- Disease
- Fatality
- Lost quality

### 27.3 Waste Management and Material Conservation

- Establish an aggressive and proactive material conservation management program.
- The plan should be flexible enough to meet the challenges and opportunities presented by legislation, regulations, advances in technology, and other influences that will affect the organization’s mission.
- The next few years will provide unique opportunities for recycling.
  - New equipment, technologies, and materials are being developed.
  - Future international meetings, legislation, and regulations have been scheduled.
  - Laws and regulations are very complex and detailed and will force everyone in business to comply with the new environmental standards.

#### 27.3.1 Objective

- The objective is to take appropriate action that will reduce material losses to the lowest practicable or achievable level, and will maximize resource reuse by recovery, recycling, and reclaiming techniques.

## 27.4 Policy Implementation to Manage Resources

- ❑ Policy implementation requires:
  - development of a general environmental guidance
  - awareness of laws and regulations
  - understanding of code and standards compliance
  - achieving of internal coordination, and keeping up with technological developments

### 27.4.1 Example: General Guidance in Refrigerants/Safety Risk Air Quality

- ❑ Operational units:
  - Take appropriate action to reduce the loss and risk of ozone-depleting refrigerants.
  - Improve and expand testing, inspection, and maintenance procedures, equipment enhancements, and refrigerant recovery, recycling, and reclamation.
- ❑ Units requiring repair:
  - Conduct lifecycle cost studies to determine whether to repair existing structurally sound CFC chillers, or to convert these chillers to less environmentally adverse refrigerants, such as HCFCs and HFCs, to extend their useful life.
- ❑ Units needing replacement or new units:
  - No new CFC chillers should be purchased. HCFC and HFC chillers, absorption machines, and purchased chilled water are acceptable alternatives.
  - All existing and emerging cost-effective technologies should be considered.

## 27.5 Terminology

- ❑ Recycling:
  - Equipment should draw out refrigerant, remove contaminants, and return cleaned refrigerant.
  - Refrigerant should be cleaned to meet ARI Standard 700-88.
- ❑ Recovery:
  - Equipment should draw refrigerant from a system and store it until reuse.
- ❑ Reclamation:
  - Develop a process to restore contaminated refrigerant to ARI Standard 700-88 at a special processing plant.

## Human Factors to Be Considered Related to Job Competencies

### Knowledge

- Methods of work
- Materials
- Machines and equipment
- Instruments and tools
- Organization
- Environment

### Psychology

- Concentration
- Fatigue
- Emotions

### Biomechanical

- Balance, coordination
- Full range of motion
- Sitting
- Standing
- Head
- Upper extremities
- Lower extremities

### Safety

- OSHA
- ANSI
- CDC
- GHS
- EPA

### Strength and Stamina

- Lift, carry, place, transfer
- Materials, objects, people
- Weight
- Height, width, length

### Sensory

- Vision
- Hearing
- Olfactory
- Skin
- Taste
- Speech

### Quality

- ISO
- Six Sigma

The importance of ergonomics relative to nanotechnology is that it is an emerging science that will need ergonomics to analyze and define how workers will do research and develop manufacturing process controls—that is, how ergonomics will support the applied development and use of particles in the forms of buckyballs, nanotubes, quantum dots, and nanogels. Each of these nano materials has unique characteristics that evolve from their original chemical composition.

It is now time to ergonomically neutralize postures used during methods of nanotechnology work. Risk managers need to think about how the body will safely engage in the job demands of working with engineered particles with dimensions in the 1–100 nanometer (nm) range. (As a reference, the width of a carbon atom is 1 nm.) Equipment such as the electron microscope is a typical part of nanotechnology laboratories. They require ergonomic analysis to support worker postures to minimize repetition and duration.

Equipment and laboratories are being designed to research engineered nanomaterial particles to be used in medical and consumer products. Nanomaterial particles are known to have safety and health effects on the human body when they are inhaled, ingested, or contact the skin. Safety questions being asked are “How does one handle, store, and dispose of nanomaterial waste?” “What is the permissible exposure limit based on the duration of work or contact?” Currently, different organizations, including the National Institute of Occupational Safety and Health (NIOSH), are researching the health and disposal aspects of nanomaterials. Initial animal studies indicate that inhaled nanomaterials can cross the lung/blood barrier (airborne and bloodborne pathogens) and deposit in internal organs. Skin penetration is another exposure route for nanoparticles. More research is needed on nanomaterials and ingestion.

Nanoscale materials and nanomaterial toxicity is not fully understood; therefore, nanomaterials must be treated with a high level of hazard control. Ergonomic job safety analysis on posture, repetition, duration, and environmental conditions (heat and cold processes) to develop safety interventions are important.

### 28.1 Ergonomic Design Benefits

- Improved productivity
- Improved safety
- Improved quality
- Legal compliance

### 28.2 Consequences of Not Using Ergonomic Design

- Lost time
- Legal citation
- Injury, illness
- Disease
- Fatality
- Lost quality

### 28.3 Improving the Match of Worker Capabilities to Methods of Work

- Define the job by competencies for knowledge, psychology, biomechanics, sensory, strength and stamina, safety, and quality.
- Validate job demands by intensity of the requirement (common sense to expert).
- Conduct job safety analysis.
- Validate job demands by frequency and severity of risk.
- Prescreen.
- Industry-specific testing, job task simulation.
- Integrate prescreening with physical and sensory demands.
- Current scientific evidence indicates that nanoparticles may be more biologically reactive than larger particles of similar chemical composition and thus may pose a greater health risk when inhaled. Some studies have suggested that the skin is also a potential route of exposure for nanoparticles. The potential health risk following exposure to a substance is generally associated with the magnitude and duration of the exposure, the persistence of the material in the body, the inherent toxicity of the material, and the susceptibility or health status of the person. The uncertainties regarding health risks with exposures to nanomaterials arise because of the gaps in knowledge about routes of exposure, and the fate of these materials once they are inside the body. Because of these uncertainties, it is important that interim precautionary measures be taken to minimize exposure. The fate of nanoparticles in the environment and subsequent human exposures is largely unknown.
- Prescreen at all levels of employment contact.
- First hired, lateral moves, promotion, return to work.

### 28.4 Improving the Methods of Work

- Integrate the knowledge competencies of the National Nanotechnology Initiative (a federal program established to coordinate multiagency efforts). They define nanotechnology as “the understanding and control of matter at dimensions of roughly 1 to 100 nanometers, where unique phenomena enable novel applications. At the nanoscale, the physical, chemical, and biological properties of materials differ in fundamental and valuable ways from the properties of individual atoms and molecules or bulk matter.”
- Physical: Coordinate and cross-train workers on static (work on microscopes) and dynamic postures to reduce occupational stress. Cross-training for laboratory functions should be based on the anthropometrics of the laboratory staff.
- Physical and Sensory: Create solutions to tracking nanomaterial data on the computer screen by color-coding data.
- Sensory: Maintain a minimum and maximum magnification range for particles. Use voice to text translation to maintain eye contact on particles while recording notes.

### 28.5 Improving the Materials of Work

- ❑ Scale material handling of nanomaterials in work areas by defined particles. This reduces the exposure ratio duration for each particle type.

### 28.6 Improving the Equipment and Machines of Work

- ❑ Scale the laboratory to work areas that have a circular radius of access to materials, equipment, and machines. This reduces repetition.
- ❑ Work with vendors in new designs to include human factors of use.
- ❑ Create solutions to overuse issues of repetitive motions and long durations at microscopes or workbenches.
- ❑ Set up computers and equipment at correct heights.

### 28.7 Improving the Instruments and Tools of Work

- ❑ By work areas, integrate the “newly designed” tools of nanotechnology to work with human factors in mind.

### 28.8 Improving the Organization of Work

- ❑ Use software to create dynamic data collection and analysis. Create dynamic schedules to maximize laboratory use.
- ❑ Appoint a work group to keep up with safety research, specifically tasked with the mission of examining the environmental health and safety (EHS) implications of existing and emerging nanotechnology. The group should formulate guidance and recommendations regarding strategies for the responsible EHS-related management of nanotechnology research and applications across all departments.

### 28.9 Improving the Environment of Work

- ❑ Nanomaterial or matter at this scale is not new and in fact, exists in nature as particles in volcanoes, forest fires, and viruses. We produce nanomaterials unintentionally as a result of combustion and have documented exposure to these ultrafine particles. The environmental health and safety implications of working with engineered nanomaterials include airborne and bloodborne risks. Nanomaterials are already being used in a number of industries, including the electronic, biomedical, pharmaceutical, cosmetic, energy, catalytic, and materials industries. Nanomaterials are often combined with other materials today to improve product functionality. Nanotechnology has the potential for reducing pollution, reducing energy consumption, and cleaning up pollution. However, with the advent of these new materials, unforeseen environmental issues or occupational hazards could arise.
- ❑ Researchers, health care experts, and process engineers must be extremely careful when working with new materials having unknown properties and toxicity.
- ❑ Integrate accessibility, adaptability, density, and design of space, lighting, and passages into safety components of nanotechnology.

### **28.10 Notable Sources of Information**

- ❑ International Council on Nanotechnology: Up-to-date postings and searchable database of nanotoxicology research
- ❑ National Institute for Occupational Safety and Health (NIOSH)
- ❑ National Nanotechnology Initiative (NNI): A federal R&D program established to coordinate the multiagency efforts in nanoscale science, engineering, and technology

## Human Factors to Be Considered Related to Job Competencies

### Knowledge

- Methods of work
- Materials
- Machines and equipment
- Instruments and tools
- Organization
- Environment

### Psychology

- Concentration
- Fatigue
- Emotions

### Biomechanical

- Balance, coordination
- Full range of motion
- Sitting
- Standing
- Head
- Upper extremities
- Lower extremities

### Safety

- OSHA
- ANSI
- CDC
- GHS
- EPA

### Strength and Stamina

- Lift, carry, place, transfer
- Materials, objects, people
- Weight
- Height, width, length

### Sensory

- Vision
- Hearing
- Olfactory
- Skin
- Taste
- Speech

### Quality

- ISO
- Six Sigma

The importance of noise to ergonomics is to consider that performance can be adversely affected by noise exposure. It is important to note that people differ in their definition of noise (music, barking dogs, crying children) and in their tolerance for it (decibel levels). In other words, to one listener a softly crying baby can be more stressful than acid rock music at 90 decibels. The lower the person's tolerance for noise, the more noise will affect that person by making him or her feel stressed and fatigued. Noise can negatively affect the performance of mental tasks (e.g., calculations), tasks that require skill and speed (e.g., fine motor repairs), tasks that demand a high level of perceptual capacity (e.g., computer-assisted drawing), and tasks that require complex psychomotor skills (e.g., retooling a machine to engineering specifications). An ergonomic strategy of noise reduction should include assessing potentially distracting noise, particularly if the noise is repetitive, ponderous, or unpredictable. Interventions can be developed case by case or department by department.

### 29.1 Ergonomic Design Benefits

- Improved safety
- Legal compliance

### 29.2 Consequences of Not Using Ergonomic Design

- Lost time
- Injury, illness
- Disease
- Fatality
- Lost quality

### 29.3 Suggested Equipment

- Office equipment
  - hoods for laser and inkjet printers
  - low noise processor fans
  - adjustable telephone rings
  - full mouthpieces
- Ceilings, walls, and floors
  - acoustic ceilings, partitions, and walls
  - levels of enclosure
  - acoustic surrounds for printers
- Mechanical systems
  - acoustically dampened, no-cycling air systems
  - balanced white or pink noise system
  - maintained perimeter heating and cooling systems

## 29.4 Acoustics

Acoustics tend to be among the most ignored priorities.

- ❑ Acoustical problems are typically more of an annoyance than an overwhelming priority.
- ❑ Many charged with a solution to these problems are not exactly sure how to solve them. The problem often tends to “go away,” because people tire of complaining.
- ❑ While there is very little statistical data about the advantages of good acoustic design, not many would argue with the conclusion that a noisy environment has a negative impact on efficiency in most work situations.
- ❑ Other spaces, such as auditoriums and cafeterias, have different criteria. In order for architects to be able to identify and resolve acoustic problems, a basic understanding of acoustics is necessary.

## 29.5 Sound and Its Measurement

- ❑ Sound is caused by fluctuations in air pressure. These vibrations of the air vibrate our eardrums, and through a network of bones and nerves are transmitted to the brain. The more fluctuations, or cycles per second (Hz), the higher the pitch.
- ❑ Sound travels through the air at approximately 1,129 feet per second (760 mph).
- ❑ An important quantitative measure of sound is the decibel (dB). This is a unit used to express relative difference in intensity between two acoustic signals, and is equal to 10 times the common logarithm of the ratio of the two levels.

### 29.5.1 The Decibel Scale Is Logarithmic

- ❑ For practical purposes, each 10 dB increase is perceived as a doubling of the sound level. Conversely, a 10 dB decrease is a reduction by half.
- ❑ When a decibel level goes from 50 to 40 dB we experience a 50% reduction, not a 29% reduction. In terms of sound energy, a 10 dB increase is 10 times greater.

### 29.5.2 Determination of Noise Reduction

- ❑ For enclosed areas (complete rooms), use the following procedure:
  - Calculate the absorption in the room and the amount of absorption to be added.
  - Acoustic absorption is measured in sabins (Sa) and is calculated by multiplying the square feet of surface area by the NRC of the material on that surface.  
Example:  $100 \text{ sf} \times \text{NRC } (.85) = 85 \text{ Sa}$ .
- ❑ The absorption change is determined by the ratio found in figure 29.1.

### 29.5.3 The OSHA Hearing Conservation Standard

The OSHA Hearing Conservation Standard is printed in 29 CFR 1910.95(a) through (o), and sets forth all applicable OSHA requirements. The standard also has several appendices containing information that is quite helpful. The excerpt below is from 29 CFR 1910.95. Please see the Code of Federal Regulations for the full standard.

<b>Absorption after Treatment (Sa)</b>											
<b>Absorption before Treatment (Sb)</b>											
Above ratio equals	1	2	3	4	5	6	7	8	9	10	20
Noise level (percentage change)	0	20	30	35	40	42	45	46	48	50	60
Decibel change	0	3	4.8	6	7	8	8.5	9	9.5	10	13

**Figure 29.1. Acoustic absorption rates.**

- Occupational noise exposure.
  - “(a) Protection against the effects of noise exposure shall be provided when the sound levels exceed those shown in Table G-16 [here labeled table 29.1] when measured on the A scale of a standard sound level meter at slow response.”
  - “(b)(1) When employees are subjected to sound exceeding those listed in Table G-16, feasible administrative or engineering controls shall be utilized. If such controls fail to reduce sound levels within the levels of Table G-16, personal protective equipment shall be provided and used to reduce sound levels within the levels of the table.”
  - When noise levels are determined by octave band analysis, the equivalent A-weighted sound level may be determined as shown in figure 29.2.

**Table 29.1 Permissible noise exposures (OSHA table G-16)**

<i>Duration per day in hours</i>	<i>Sound level dBA (slow response)</i>
8	90
6	92
4	95
3	97
2	100
1?	102
1	105
?	110
? or less	115

Note: When the daily noise exposure is composed of two or more periods of noise exposure of different levels, their combined effect should be considered, rather than the individual effect of each. If the sum of the following fractions:  $C1/T1 + C2/T2 + \dots + Cn/Tn$  exceeds unity, then the mixed exposure should be considered to exceed the limit value.  $Cn$  indicates the total time of exposure at a specified noise level, and  $Tn$  indicates the total time of exposure permitted at that level. Exposure to impulsive or impact noise should not exceed 140 dB peak sound pressure level.

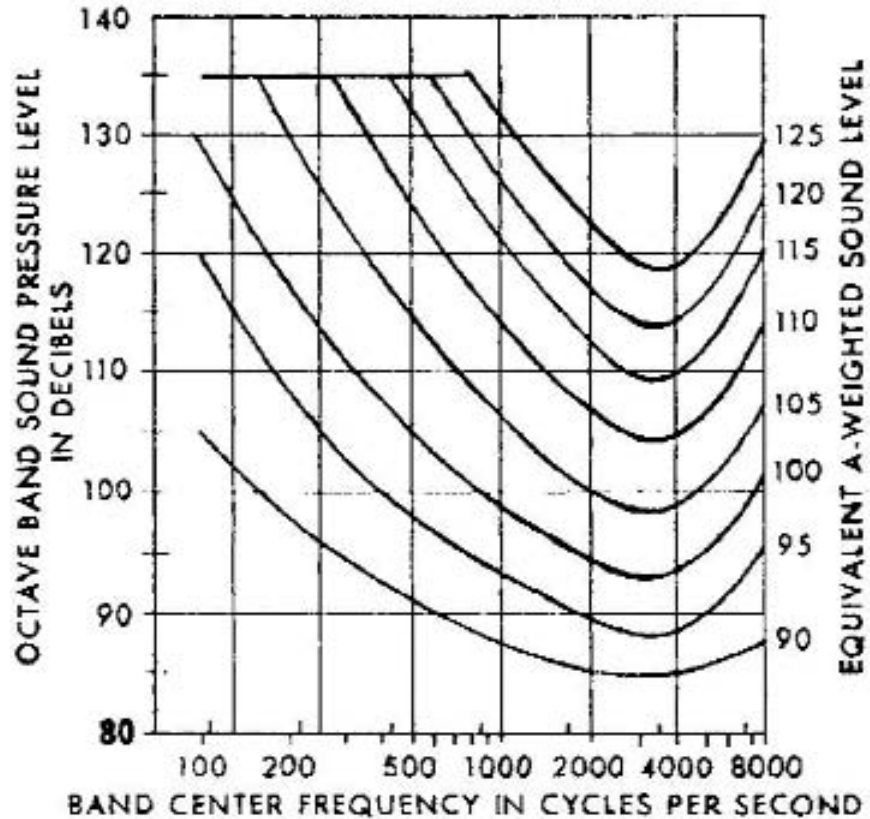

Figure 29.2. Band center frequency in cycles per second.

#### 29.5.4 Equivalent Sound Level Contours

- Octave band sound pressure levels may be converted to the equivalent A-weighted sound level by plotting them on this graph and noting the A-weighted sound level corresponding to the point of highest penetration into the sound level contours. This equivalent A-weighted sound level, which may differ from the actual A-weighted sound level of the noise, is used to determine exposure.

## Human Factors to Be Considered Related to Job Competencies

### Knowledge

- Methods of work
- Materials
- Machines and equipment
- Instruments and tools
- Organization
- Environment

### Psychology

- Concentration
- Fatigue
- Emotions

### Biomechanical

- Balance, coordination
- Full range of motion
- Sitting
- Standing
- Head
- Upper extremities
- Lower extremities

### Safety

- OSHA
- ANSI
- CDC
- GHS
- EPA

### Strength and Stamina

- Lift, carry, place, transfer
- Materials, objects, people
- Weight
- Height, width, length

### Sensory

- Vision
- Hearing
- Olfactory
- Skin
- Taste
- Speech

### Quality

- ISO
- Six Sigma

The importance of organizational commitment to ergonomics is clear. When leadership sets the tone for safety, the culture of safety grows. The best way to implement an ergonomic program is through the safety committee forum. Once committees are formed they become the monthly review team where hazards are identified and a plan for near miss and accident investigations result in positive changes. Ergonomics is a foundation of safety in any organization. Safety committee members become the eyes and ears of safety, and as they act as the ambassadors of safety, a more open approach to change grows.

How to begin? Develop a mission statement that reflects the organization's safety policies and procedures. Remember, organizations that have safety programs with safety meetings representing labor and management produce safety results that build employee commitment. The following are examples of mission and purpose statement, ergonomic applications, activities, and outcomes. Included is a summary of how responsible people in an organization work together to create a safety culture that is ergonomics based.

### 30.1 Ergonomic Mission Statement

- The importance of ergonomics to organizations is threefold.
  - to work toward providing a safe and healthful living, learning, and working environment for every member of the greater organization by ensuring safe work practices through educating, training, and assisting individuals and departments;
  - to help individuals and departments achieve compliance with all health and safety state and federal regulations and our organizational policies as economically as possible; and
  - to act as liaison with external regulatory agencies, and to monitor industry compliance with mandatory health and safety standards where necessary.

### 30.2 Purpose

The strategy to reduce the ergonomic risks of force, awkward posture, repetition, duration, cold and heat stress, and vibration is represented in the statement of purpose, which meets all levels of work management.

- To provide policies and procedures for the protection of employees from ergonomic risk factors.
- To establish an ergonomics program that provides employees with the following services:
  - detection, correction, and prevention of musculoskeletal disorders by anticipating, identifying, and reducing ergonomic risk factors
  - promotion of awareness of ergonomic risk factors and proper reporting of signs and symptoms of musculoskeletal disorders
  - coordination and promotion of ergonomics technology applications

The purpose is an organized effort for the systematic coordination of leadership, supervisors, employees, and environmental health and safety to prevent occupational musculoskeletal disorders.

### 30.3 Ergonomic Applications

The primary tools that an ergonomics program employs to administer to employees include:

- ❑ Training supervisors and employees in the awareness of and proper reporting of ergonomic risk factors and early reporting of signs and symptoms of musculoskeletal disorders
- ❑ Review of incident and workers' compensation records
- ❑ Conducting workplace ergonomic risk assessments based on anticipated or reported ergonomics issues
- ❑ Creating documents, work flow, and organizational standards of work protocols that minimize ergonomically defined risks
  - Competency-based job descriptions that define essential functions by knowledge, psychology, biomechanics, sensory, strength and stamina, safety, and quality
  - Prescreen protocols for workers as new hires and in transition with lateral moves, promotions, and return to work from disease, disability, or injury.
- ❑ Consulting on engineering and administrative ergonomic hazard reduction and control to eliminate, accommodate, mechanize, automate, or robotize out the risks
- ❑ Educating about the potential effects of ergonomic risk exposures by promoting wellness

### 30.4 Safety Meetings, Activities, and Outcomes

- ❑ Safety meetings change culture with activities and outcomes.

#### 30.4.1 Safety Meeting Guidelines

- ❑ Set up a committee representing management and labor, with at least two managers and worker representatives from all departments.
- ❑ Meet once a month to discuss; take minutes and publish your minutes and reports in a newsletter. Standard meeting topics should include:
  - near miss
  - accidents
  - accident investigation using job safety analysis
  - interventions
  - engineering controls
  - accommodation
  - supervision of safety
  - training

NOTE: While safety meeting interactions and education enhance understanding of ergonomics, job-title and worker-specific consultations have historically been the main tools to evaluate risk factors and fashion solutions.

Ergonomic programs include activity and outcome measures. Both are important to adequately determine whether an ergonomics program is effective.

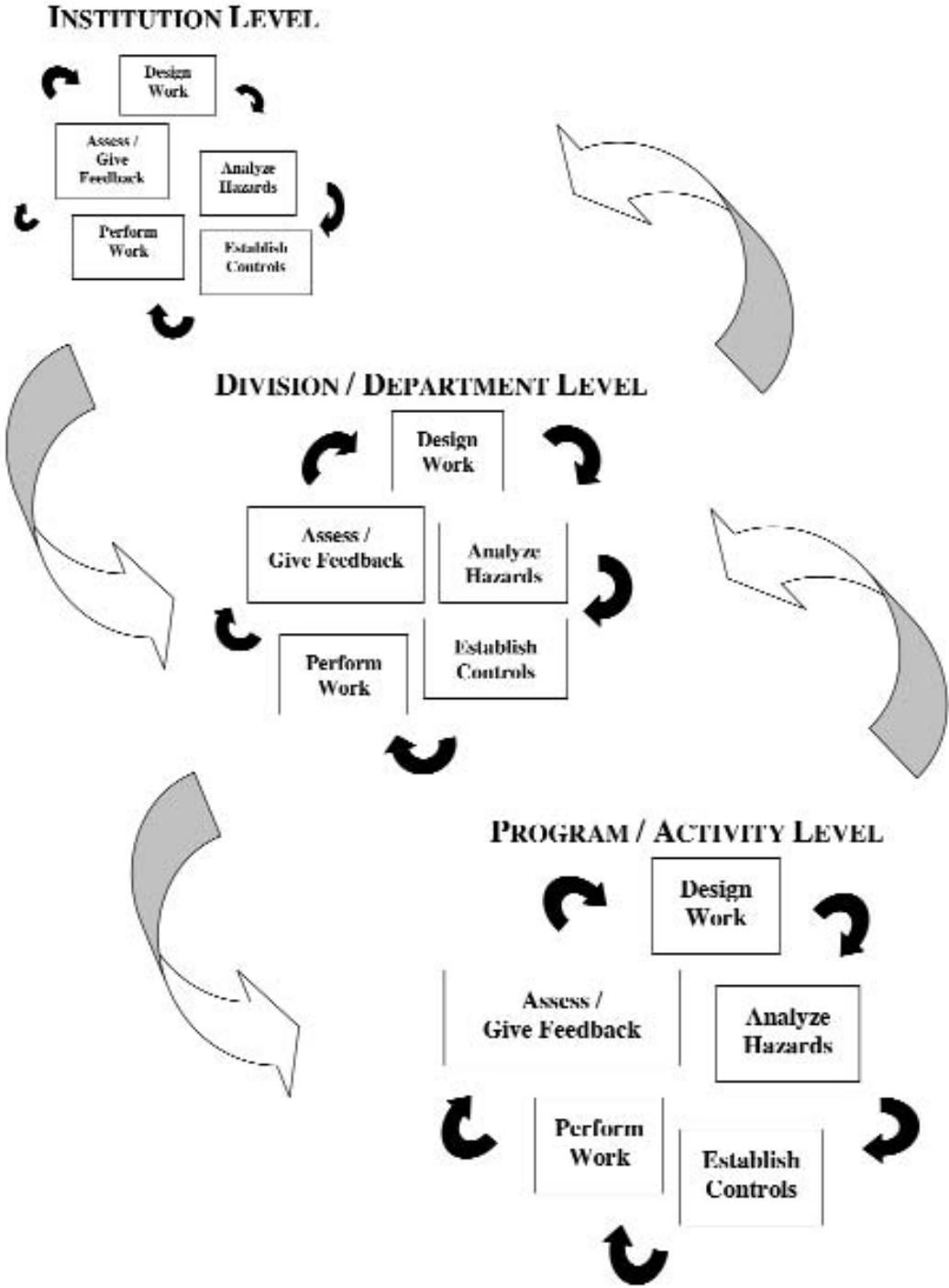

Figure 30.1. How organizations create work management flow.

### 30.4.2 Activity Measures

Activity measures help identify whether the elements of your program are functioning as a systematic process. This type of measure indicates whether “mid-course” corrections are needed to achieve targeted long-term goals and whether the program is set to respond quickly to problems that arise in the future. Activity measures also provide ways to measure interim or in-process accomplishments achieved along the path to building a program that is effective in eliminating or reducing MSDs and MSD hazards. This is particularly important if it takes time before quantitative successes can be measured.

### 30.4.3 Outcomes Measures

Outcomes measures are the most telling in terms of defining a successful program because they measure quantitative bottom-line results. They identify whether the program eliminates or reduces MSDs, MSD hazards, and related costs.

## 30.5 Responsibilities

### 30.5.1 Safety Committee Members: Agendas and Outcomes

- Hold monthly meetings with representative employees and managers to discuss hazards and interventions.
- Train employees and supervisors in the need for, and the methods of, early reporting of MSD signs and symptoms.
- Educate supervisors and employees about ergonomic risk factors and the potential harm to their bodies.
- Recommend and coordinate the development of ergonomic risk factor reporting and case-tracking mechanisms, and early sign and symptoms reporting.
- Perform ergonomic risk factor measurements and observations and communicate results to supervisors and employees.
- Establish a job hazard analysis and control process that identifies, analyzes, and uses feasible engineering, work-practice controls to eliminate MSD hazards that reduce MSD hazards to the extent feasible.
- Establish ways to evaluate controls to ensure that they are effective.
- Prioritize ergonomic evaluations based on available severity, prevalence, and incident rate data (e.g., OSHA logs, first report of injury, workers' compensation, discomfort surveys).

### 30.5.2 Supervisors

Supervisors are key personnel in promoting and maintaining a safe local work environment. Supervisory responsibilities related to the ergonomics program are to:

- Set a departmental climate that encourages active employee participation.
- Encourage early reporting of signs and symptoms of MSDs.
- Notify the safety committee of any physical hazards and of employee musculoskeletal signs and symptoms.

- ❑ Notify the safety committee of physical hazards or changes in workplace processes or equipment that may change (increase or decrease) ergonomic risk factors.
- ❑ Ensure that the proper level of ergonomics training is provided to employees.
- ❑ Provide solutions and funding to implement corrective measures to identified ergonomic risk factor exposures.

### 30.5.3 Employees

As the group most directly impacted by musculoskeletal disorders and their related discomfort and potentially disabling effects, employees are to:

- ❑ Report early signs and symptoms of musculoskeletal disorders.
- ❑ Follow work practice procedures related to their jobs that are intended to reduce ergonomic risks.
- ❑ Actively participate in the recognition, analysis, and abatement of ergonomic risks.

## Human Factors to Be Considered Related to Job Competencies

### Knowledge

- Methods of work
- Materials
- Machines and equipment
- Instruments and tools
- Organization
- Environment

### Psychology

- Concentration
- Fatigue
- Emotions

### Biomechanical

- Balance, coordination
- Full range of motion
- Sitting
- Standing
- Head
- Upper extremities
- Lower extremities

### Safety

- OSHA
- ANSI
- CDC
- GHS
- EPA

### Strength and Stamina

- Lift, carry, place, transfer
- Materials, objects, people
- Weight
- Height, width, length

### Sensory

- Vision
- Hearing
- Olfactory
- Skin
- Taste
- Speech

### Quality

- ISO
- Six Sigma

**H**ow workers move through facilities is part of a critical ergonomic evaluation. Slips, trips, and falls are still a major contributor to back and hip injuries. Workers must be allowed safe and clear passage when moving from one part of the facility to another. In addition, all material handling procedures should be reviewed to determine what areas present a high risk.

### 31.1 Ergonomic Design Benefits

- Improved safety
- Legal compliance

### 31.2 Consequences of Not Using Ergonomic Design

- Lost time
- Injury, illness
- Disease
- Fatality
- Lost quality

### 31.3 Circulation System

- The movement of people between floors can affect productivity.
- Circulation of workers increases productivity. For that reason, moving stairs and even fixed-stair designs may benefit an organization by getting more people to talk informally away from their work areas, and thus generate more ideas.  
—Tom Allen, MIT professor and noted designer of high-tech facilities, suggests that 80% of good ideas result from informal communication.

#### 31.3.1 Circulation and Interaction Facilities Typical Functions

- Facilities that foster interaction serve multiple purposes. In general, they are common or shared-use facilities that are located within a high-traffic zone. Not only do they encourage interaction, but they also offer a refuge (or relief) from the primary work area.
- The right location, configuration, and operation of these facilities can increase chance encounters and promote informal contacts among occupants. They are sometimes referred to as “magnets” because of their attraction feature. These facilities include:
  - restrooms
  - copy machines
  - coffee stations
  - cafeterias
  - special equipment areas
  - supply rooms
  - conference rooms
  - other shared areas
- Interaction patterns can be further enhanced by facility areas that provide a setting for occupants to stop and meet informally. These facilities include:



Figure 31.1. Passages need to be well marked.

- walkways/hallways
- atria
- lobbies
- courtyards
- elevators/escalators/stairwells

### 31.4 General Considerations

- ❑ Many factors contribute to making a productive and creative workplace. To be successful, a workplace must help the organization be both efficient and effective.
- ❑ Increased competition has shortened the effective lifespan of both products and knowledge. An efficient organization must have a shorter elapsed time period from invention to new product introduction than their competitors have.

## Human Factors to Be Considered Related to Job Competencies

### Knowledge

- Methods of work
- Materials
- Machines and equipment
- Instruments and tools
- Organization
- Environment

### Psychology

- Concentration
- Fatigue
- Emotions

### Biomechanical

- Balance, coordination
- Full range of motion
- Sitting
- Standing
- Head
- Upper extremities
- Lower extremities

### Safety

- OSHA
- ANSI
- CDC
- GHS
- EPA

### Strength and Stamina

- Lift, carry, place, transfer
- Materials, objects, people
- Weight
- Height, width, length

### Sensory

- Vision
- Hearing
- Olfactory
- Skin
- Taste
- Speech

### Quality

- ISO
- Six Sigma

The importance of ergonomics to personal protective equipment (PPE) is that it matches OSHA and industry requirements to the human factor needs of workers. Ergonomics evaluations of PPE balance the “fit” criteria between hazard interventions and human factors in both macro- and microenvironments. PPE should lower risk in both macro- and microenvironments. The macroenvironment represents the industry process and the facilities. The microenvironment represents the individual and job demands. PPE should maintain safe job actions, human comfort, and health. Job safety analysis, health and safety standards and regulations of risk, and hazard identification define the PPE need. People and their human factors dictate “fit.”

PPE worn by an individual is a microenvironment that has physiological consequences. For example, thermal clothing creates a microclimate for the body. If the fabrics are not breathable, such as in the case of chemical and biological protective clothing, it can affect the body’s cardiovascular system by creating heat stress that raises blood pressure. A person with allergies can have breathing compromised by a poorly fitting respirator or excessive duration of need. A sweat effect can increase hydration needs that if left unsatisfied cause fatigue and eventual disorientation. The ergonomic goal of PPE is to fit the individual worker, be appropriate for the task being done, and not contribute to extreme postures, excessive constraining force, repetition, or duration. The optimum is comfort, health, and performance in both the macro- and microenvironments.

### 32.1 Ergonomic Design Benefits

- Improved productivity
- Improved safety
- Improved quality
- Legal compliance

### 32.2 Consequences of Not Using Ergonomic Design

- Lost time
- Legal citation
- Injury, illness
- Disease
- Fatality
- Lost quality

### 32.3 Improving the Match of Worker Capabilities to Methods of Work

- Define the job by competencies for knowledge, psychology, biomechanics, sensory, strength and stamina, safety, and quality.
- Validate job demands by intensity of the requirement (common sense to expert).
- Conduct job safety analysis.
- Validate job demands by frequency and severity of risk.
- Prescreen.
- Industry-specific testing, job task simulation.

- ❑ Prescreen workers at each stage of employment.
- ❑ First hired, lateral moves, promotion, return to work.
- ❑ Screen for essential functions that may be validly compromised by age, disease, disability, injury.
- ❑ Job safety analysis factors may dictate screening for human factors consequences, PPE, and competence to take safe actions.
- ❑ Biomechanical:
  - grip with gloves and force required to manipulate objects
  - neck strength to wear hard hats or heavy hooded face protection
  - shoulder width and length for thermal protective clothing
  - range of motion in full-body suits that does not impede reflexes
  - lower body constraints with knee pads for walking vs. kneeling tasks
  - foot flexibility with friction coefficient (amount of friction or grip between floors and shoes)
- ❑ Sensory:
  - hearing: acuity to distinguish sounds with hearing protection
  - vision: acuity to distinguish objects with darkened shields or tinted glasses
  - smell: acuity to determine smell in confined space
  - sensation: acuity to distinguish temperature through gloves
  - taste: acuity to distinguish sweet, sour, bitter, salty

#### 32.4 Improving the Methods of Work

- ❑ Integrate the knowledge, psychological, safety, and quality competencies of business requirements with the physical and sensory demands.
- ❑ Physical: Coordinate and cross-train workers on the integrated fit of all PPE for specific job tasks.
- ❑ Clothing should have vapor release.
- ❑ Gloves can protect the hands from injury or cold, but they also may reduce dexterity and increase grip force. When choosing gloves, consider these factors:
  - Gloves should be small enough to minimize wrinkling or slipping but large enough so they don't impede circulation.
  - Padding or insulation can add protection.
  - Texturing improves friction. If chemical resistance is not a concern, material should be breathable so perspiration is not trapped.
- ❑ Footwear/anti-fatigue insoles: Anti-fatigue insoles can give relief from musculoskeletal fatigue that develops from prolonged standing and walking on hard floor surfaces. They are especially appropriate when anti-fatigue floor mats cannot be used because of housekeeping needs, the size of the area to be covered, or tripping hazards.
- ❑ Kneepads can be used to avoid prolonged contact with hard or sharp surfaces. They should be comfortable, large enough to cover the entire knee, padded, and snug enough to fit well but not so tight that they impede circulation.
- ❑ Create safe action protocols for high strength and stamina tasks.
- ❑ Sensory: Set up work protocols to increase eye-hand and all sensory coordination (sight, hearing, touch, smell, taste).

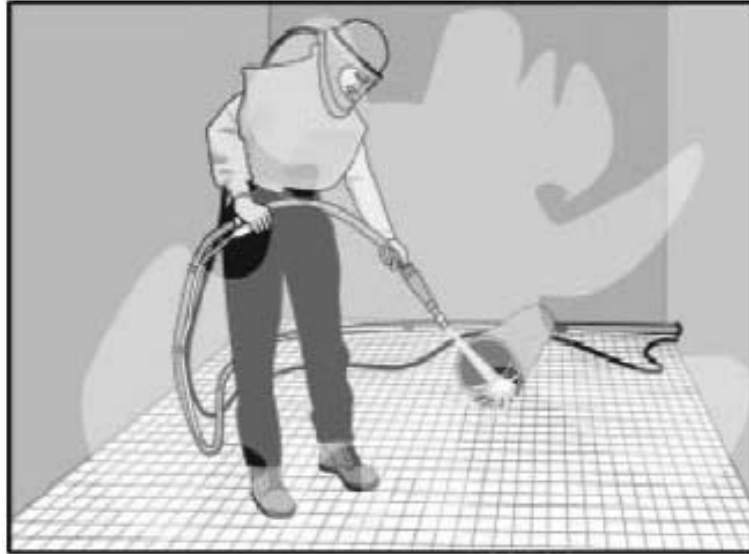

**Figure 32.1. Personal protection equipment is job-demand specific.**

### **32.5 Improving the Materials of Work**

- Purchase materials with lowered risk such as water-soluble chemicals.
- Integrate the knowledge competencies of safe actions when using PPE with materials and moving material handling equipment.

### **32.6 Improving the Equipment and Machines of Work**

- Control the access points to hazards to reduce risk.
- Control the sensory overload of noise with sound dampening.
- Create solutions that increase automation.

### **32.7 Improving the Instruments and Tools of Work**

- Purchase ergonomic instruments and tools for job tasks that work well with PPE requirements.

### **32.8 Improving the Organization of Work**

- Optimize work processes to eliminate the need for PPE.
- Integrate safety stations in the right work areas.
- Safety glasses with eye wash stations.
- Hearing protection with noise meters.
- Train and cross-train.
- First response.
- First aid.
- Emergency evacuation.

### 32.9 Improving the Environment of Work

- ❑ Optimize the work environment for both the mental and physical state of workers.
- ❑ Signage is key to work-area identifiers for PPE identification.
- ❑ In clean and sterile rooms
- ❑ Add anti-fatigue mats where appropriate.
- ❑ Monitor humidity and oxygen.
  - Less humidity is less allergens and pollutants, workers breathe easier.
  - With less oxygen in the air, people breathe more deeply, expelling more carbon dioxide which allows more oxygen into the brain.
- ❑ Evaluate the necessary stimulation in environments.
  - Lack of stimulation can create extreme violent reactions, such as the cabin fever of long Siberian winters, or hysteria leading to violence
  - Evaluate environmentally dull enforced confinement.
  - There are reports of more hypochondria and psychosomatic problems in such places as polar stations and submarines, as people spend too much time looking inward.
- ❑ Integrate accessibility, adaptability, density, design of space, housekeeping, lighting, passages, temperature, and training into safety components of PPE.

## Human Factors to Be Considered Related to Job Competencies

### Knowledge

- Methods of work
- Materials
- Machines and equipment
- Instruments and tools
- Organization
- Environment

### Psychology

- Concentration
- Fatigue
- Emotions

### Biomechanical

- Balance, coordination
- Full range of motion
- Sitting
- Standing
- Head
- Upper extremities
- Lower extremities

### Safety

- OSHA
- ANSI
- CDC
- GHS
- EPA

### Strength and Stamina

- Lift, carry, place, transfer
- Materials, objects, people
- Weight
- Height, width, length

### Sensory

- Vision
- Hearing
- Olfactory
- Skin
- Taste
- Speech

### Quality

- ISO
- Six Sigma

The importance of ergonomics in pick patterns or “slotting” involves the match of workers’ biomechanical and sensory coordination to meet productivity standards. The standards of productivity, safety, and quality involve the worker’s strength and stamina to “pick” continuously, without fatigue, and to select items correctly 100% of the time. The ergonomic design of the environment includes the assignment of a fixed pick location to each item in a distribution center. Slotting is a critical efficiency strategy in operating environments where fixed pick locations are used. In most distribution centers, the picking function is responsible for over 50% of the labor force job demands. The value of ergonomics is to match effective pick/slotting patterns to worker competencies. Ergonomics is one of the most important contributing factors to increasing the workers’ integrated consistency in productivity, safety, and quality.

Ergonomics guides worker and pick pattern interactions to engage in an effective pick pattern/slotting strategy. An ergonomic approach results in maximum warehouse labor productivity, reduced operator injuries, reduced product loss/spoilage/damage, improved quality of shipping pallets, reduced outbound pallets and shipping cartons, lower transportation costs, improved product security, reduced risk of exposure to hazardous accidents, and improved order-to-ship turn-around time. An ergonomically designed pick pattern/slotting strategy is one of the most important elements of a successfully run distribution center.

### 33.1 Ergonomic Design Benefits

- Improved productivity
- Improved safety
- Improved quality
- Legal compliance

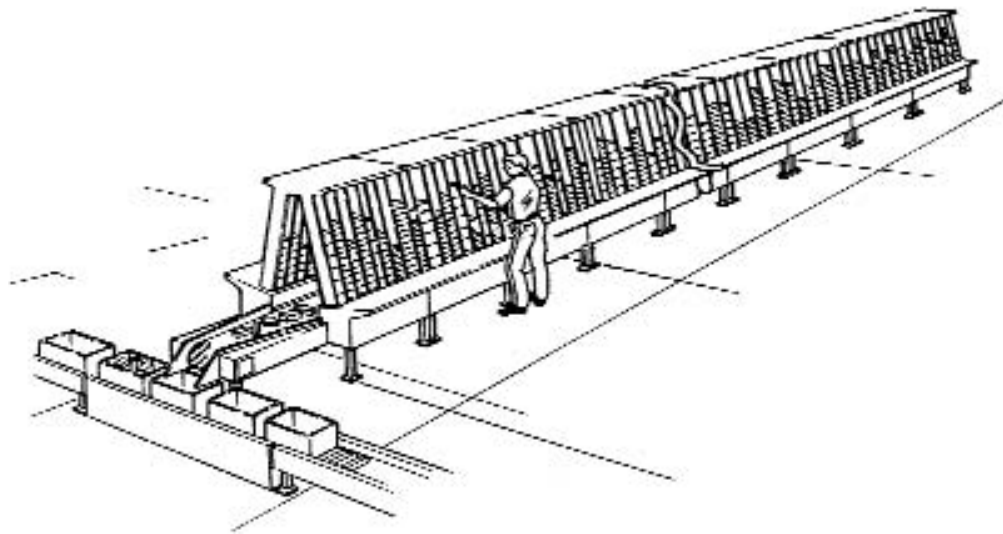

Figure 33.1. Pick patterns should consider worker reach and balance.

### 33.2 Consequences of Not Using Ergonomic Design

- Lost time
- Legal citation
- Injury, illness
- Disease
- Fatality
- Lost quality

### 33.3 Improving the Match of Worker Capabilities to Methods of Work

- Define the job by competencies for knowledge, psychology, biomechanics, sensory, strength and stamina, safety, and quality.
- Validate job demands by intensity of the requirement (common sense to expert).
- Conduct job safety analysis.
- Validate job demands by frequency and severity of risk.
- Prescreen.
- Prescreen workers at each stage of employment.
- First hired, lateral moves, promotion, return to work.
- Screen for essential functions that may be validly compromised by age, disease, disability, injury.
- Eye-hand coordination.
- Manual dexterity.

### 33.4 Improving the Methods of Work

- Integrate the knowledge competencies of business requirements with the physical and sensory demands.
- Standardize product sizes.
- Reduce “extreme” working conditions, such as duration-related cold stress in freezers or on docks.
- Physical: Coordinate and cross-train workers on static and dynamic postures to reduce occupational stress.
- Cross-training could include order processing and transportation of inventory from warehousing through all order processes.
- Design the numbering system with the least amount of sequential steps from each address location to each unique storage or ship location in the distribution center.
- A numbering system has five distinct competency and ergonomic features:
  - logic
  - sequence
  - predictability
  - readability
  - cross-referenced reinforcement of selection
- Physical and Sensory: Create tactile solutions from tag tracking of product to simple visually keyed bar code stock locators.
- Sensory: Voice recognition technology enables “pickers” to give and receive voice instructions from a headset that enables the paperless environment. This increases

order accuracy, real time order/inventory management transport, and integration of cross-department staffing.

### 33.5 Improving the Materials of Work

- ❑ Integrate the knowledge competencies of business requirements with the physical and sensory demands.
- ❑ Ergonomic strategies are dynamic in pick pattern/slotting sequences.
- ❑ Cross-referenced to force, posture, repetition, duration, and temperature stress are:
  - item’s physical dimensions and weight
  - movement velocity
  - shipping format
  - packaging
  - product family
  - inventory value
  - temperature requirements
  - security requirements
  - hazardous materials characteristics

### 33.6 Improving the Equipment and Machines of Work

- ❑ Scale the access points for workers to reduce awkward postures, such as overreach postures to pick locations on shelves.
- ❑ Use preventive maintenance of equipment and machines to reduce force needed to work with or on equipment and machines that automate the inventory from the pick or slot to a conveyor.
- ❑ Match just-in-time processing with consideration to worker schedules. Reduce overtime demands.
- ❑ Conduct on-site departmental inspections of materials handling equipment to ensure that original specification requirements and facility layout plans are respected at all times.
- ❑ Most materials handling equipment suppliers outsource the equipment installation function to subcontractors, and the quality of installation work is often sacrificed in the interests of getting the job done quickly.
- ❑ Reserve the right to final ergonomic approval of the quality and accuracy of equipment and machine installation.
- ❑ Set up computers at correct heights and create web visibility of inventory, pick-to-order sequences, shipments, or through intra-web collaborative efforts.

### 33.7 Improving the Instruments and Tools of Work

- ❑ By work areas, integrate the throughputs between departments from pick locations to final packaging and vice versa.
- ❑ Purchase ergonomic tools and use ergonomic setup guidelines to meet task demands, such as opening and closing packages that take one item from a packaged six-pack of inventory.

### 33.8 Improving the Organization of Work

- ❑ Integrate the knowledge competencies of business requirements with the physical and sensory demands.
- ❑ Training: The implementation of technical changes requires training on new operating procedures.
- ❑ Ergonomics dictates the use of job safety analysis to devise.
- ❑ Picking methodology tactic(s) using simple numbering systems to pick orders in the distribution center.
- ❑ Development of a changeover planning process to minimize risk to the operation and to ensure that people experience hands-on training and support before “go-live.”
- ❑ Software parameters to create dynamic routing that optimizes the assignment of inbound product parts and outbound orders applications.
- ❑ Create dynamic schedules that deploy for multiple stops per load.
- ❑ Digitized plant networking to develop accurate times for product or load transfers to begin routing.
- ❑ NOTE: The use of hardware and software is a knowledge competency. However, there are numerous psychological issues that need to be dealt with as hardware and software technology is introduced:
  - Operators may not speak the same language as supervisors.
  - They may be illiterate.
  - They may never have worked with a computer before.
  - They may resist the change of having a computer instruct them on what to do.
  - They may fear that the technology will eliminate their job.

### 33.9 Improving the Environment of Work

- ❑ Integrate the knowledge competencies of business requirements with the physical, sensory, safety, and quality demands.
- ❑ Integrate the ergonomic design factors of accessibility, adaptability, comfort, communication, density, design, division of space, finishes, lighting, material handling, relocation, training, transport, vendors, and windows.
- ❑ The environment of work is critical in a pick pattern/slotting layout.
- ❑ Any numbering system should be flexible enough to allow new aisles, racks, rack levels, etc., to be easily inserted into the layout without a major renumbering effort required.
- ❑ Integrate air quality, density, design of space, lighting, passages, signage as components of interplant transfer.
- ❑ Facility design ensures the efficiency of distribution centers.
- ❑ Specific architectural considerations include lighting, placement of heaters and cooling units, integration of the sprinkler system with the racking, floor loading, dock levelers, doors, door seals, placement of electrical outlets, placement of fire escapes, placement and sizing of the battery charging area, safety equipment requirements (security and fire), and the Americans with Disabilities Act of 1990.

## Human Factors to Be Considered Related to Job Competencies

### Knowledge

- Methods of work
- Materials
- Machines and equipment
- Instruments and tools
- Organization
- Environment

### Psychology

- Concentration
- Fatigue
- Emotions

### Biomechanical

- Balance, coordination
- Full range of motion
- Sitting
- Standing
- Head
- Upper extremities
- Lower extremities

### Safety

- OSHA
- ANSI
- CDC
- GHS
- EPA

### Strength and Stamina

- Lift, carry, place, transfer
- Materials, objects, people
- Weight
- Height, width, length

### Sensory

- Vision
- Hearing
- Olfactory
- Skin
- Taste
- Speech

### Quality

- ISO
- Six Sigma

The importance of planning in ergonomics is to define goals and objectify a process that develops an obvious set of procedures that result in solutions. In the systematic consideration of workers, ergonomics focuses attention on four aspects of human mechanics: how people move (biomechanics), how people use their senses, how people feel on the job (psychologically), and how people think.

The idea is to reduce the risks of occupational illness and injury by planning an ergonomically fit safety program with a timeline and considerations for human resources and expense. Administrative procedures for purchasing and worker safety guidelines should be established. Worksite analysis should be done to determine and prioritize risks. Hazard engineering controls should be used to abate and reduce risks. Occupational health practitioners will provide medical management to help prevent and reduce lost work time and injury. And finally, training must be conducted to help workers become their own safety and ergonomic analysts, contributing to the team effort that will turn ergonomic paper plans into workplace action plans.

### 34.1 Ergonomic Design Benefits

- Improved safety
- Legal compliance

### 34.2 Consequences of Not Using Ergonomic Design

- Lost time
- Increased cost
- Injury, illness
- Disease
- Fatality
- Legal citation

### 34.3 Sample of Planning a Project

- See table 34.1.

### 34.4 Ergonomic Approach to Architectural Design Planning

- The process of sustaining a competitive edge through ergonomics provides tremendous opportunity for an organization. Yet, it is just the first phase in a constant process of assessing strengths and weaknesses, making recommendations, and managing change.

#### 34.4.1 Decision-Making Process

- Take time to think about and plan who in the client organization will make the final decision on the recommended changes.
- A carefully chosen team of managers within the client organization should review the plan and its progress, as well as help sell it to senior management.
- Keep senior managers and other stakeholders involved at all times. If there are internal review committees, go over the plans with selected members before making formal presentations.

**Table 34.1 Project planning**

<i>Name</i>	<i>Scheduled start date</i>	<i>Scheduled finish date</i>
Confirm team	10/03/200_	10/14/200_
Develop schedule	10/03/200_	10/14/200_
Establish fee budgets	10/03/200_	10/14/200_
Prepare questionnaire	10/17/200_	10/21/200_
Prepare presentation	10/17/200_	10/21/200_
Outline objectives and purpose	10/24/200_	10/28/200_
Obtain approval to proceed	10/24/200_	10/28/200_
Distribute questionnaire	10/24/200_	10/28/200_
10-year projections	10/31/200_	11/07/200_
Areas of potential change	11/14/200_	11/18/200_
Present statistics and data	11/21/200_	11/25/200_
Confirm results and conclusions	11/21/200_	11/25/200_
Presentation to board members	11/28/200_	12/02/200_

#### 34.4.2 The Process Flow Chart

- ❑ Use a critical path method (CPM) or performance evaluation and review technique (PERT) to create a process flow chart delineating the steps to be undertaken during the proposed change.
- ❑ Assign beginning and ending dates for all the process steps to be completed. The process from start to finish may involve hundreds of separate, discrete actions, including every meeting date, delivery, and decision.
- ❑ To help in this effort, a project manager should make sure that the logic is correct, and that the most critical parts of the process are properly identified.
  - Prioritize opportunities.
  - Identify customer needs, expectations, and goals.
  - Identify the product or service that is provided.
  - Identify the department for each product or service and determine what department members consider to be important.
  - Identify the capacity to provide design support for the product or service.
  - Map the current process, and specify measurements.
  - Assess the process capability.
  - Initiate a defect analysis, and determine actions to be taken.
  - Define and document the process for doing the work.
  - Document the improvement and set future target goals.
  - Implement action.
  - Mistake-proof the process and eliminate wasted efforts.
  - Benchmark the process.
- ❑ Plan on having at least six hours of team meetings a month, for 12 months, for all key people.
- ❑ Each team member will also need to prepare for 2 to 10 hours before each meeting.
- ❑ Specialists from within or outside the organization may be needed to occasionally assist and to suggest new methods.

- The total cost of the first year's program alone could run well into six figures. With this sizable investment, it is imperative that upper management support the project 100%.

### 34.5 Establishing a Vision

Establishing a vision of where to ultimately lead the organization is important, as is establishing a competitive edge and setting realistic goals.

- Allow the customer's input to affect the design process.
- Choose an architect well versed in ergonomics. A well-prepared mission statement will then be a natural outgrowth.
- Determine and state why you are undertaking this process.
  - A suggested opening for the purpose statement would be: "We are undertaking this process of assessment and change in order to maintain competitiveness and high performance in all areas of the safety management business."
- Establish early on a very strong customer relationship and emphasize the importance of employee involvement by stating, "We will accomplish this by developing strong customer and vendor relationships and by involving our employees in all stages of data collection and decision making."
- State (and believe) that there are no preordained conclusions.
  - One way might be to adopt the following in the conclusion of the purpose statement: "This will be an open process leading to one of many possible, viable solutions."

### 34.6 User Enrollment

- User involvement in this process is important.
- The process of building a team is based on mutual trust and respect.
- People take more personal responsibility for higher quality and lower cost when they have as much knowledge, involvement, and choice as possible.
- Participation also deepens commitment and decreases rumors and misinformation.
- The suggested essential steps in this process are:
  - Announce the program in a formal meeting, with everyone from the entire organization present. Carefully explain the purpose of the program.
  - Announce the results of each stage of the process to your employees.
  - Involve everyone in the process of formally defining roles and responsibilities, focusing on the customer, work modeling, and measurement.
  - Develop the capabilities of the employees to actively participate in each of these processes.
  - Share the results with your employees; involve them in the process of fine-tuning.
  - Use every opportunity to discuss the process with everyone involved.
  - It is important to recognize that all participants will be well aware that management is undertaking a serious effort to bring about change. It is best to share as much information as possible.
  - Continue to evaluate all aspects of the business as it changes, and actively encourage all employees to support the progress.

- Sustaining the ergonomic edge is the first step in an evolutionary process that involves everyone in creating the type of organization they truly want.
- The greatest boon to developing a fully actuated, fully self-managed work group is the improvement of individual and team capabilities.

### 34.7 Focusing on the Customer

The most valuable lesson to learn is the importance of a systematic approach to focusing on the customer's requirements. This will result in the most benefits for employees as well as for customers.

- Establish the identities of your customers.
- Let them know that they are valuable customers.
- Learn precise customer requirements.
- Establish a clear connection between what they get and what they pay for.
- Sustain this effort for future improvement.

### 34.8 Work Modeling

As the above process unfolds, it becomes more apparent what the customer wants and what the employees are capable of providing.

- Maintain a purposeful decision-making procedure in order to evaluate the benefits (or liabilities) of alternative methods of providing facility services. This is especially true when it comes to evaluating in-house work forces vs. outsourcing options.
- Assess the skill level required to operate the facility, and the current resources or capabilities available to meet those needs, before any changes are made to the department organizational structure or teams.
- Decide whether to centralize or decentralize. This is called “work modeling,” and there are numerous methodologies to do it. Here are some of the general steps to follow:
  - Conduct an inventory of equipment and components.
  - Prepare performance guidelines in conjunction with formal definition of roles and responsibilities.
  - Determine work quantities.
  - Conduct a risk assessment.
  - Conduct a capability assessment.
  - Recommend improvements and implementations.

#### 34.8.1 Building Components

Develop specifications for all major building components.

- This requires an accurate inventory and condition assessment for all physical assets or major building components.
- A detailed inventory requires tremendous labor to initiate and maintain, but it does provide all the details needed.

- ❑ A focused performance guideline for each predictive, preventive, or routine work step must be provided for each building component or system.
- ❑ Each performance guideline needs to specify the purpose of the guideline, employee responsibilities, how often tasks are to be performed, the expectations of customers and facilities management, key drivers and measurement parameters, and how to measure success.
- ❑ After performance guidelines are determined, the quantity of work needing to be done at the facility is established. In other words, the service level or frequency of occurrence is established.
- ❑ Cost factors can be included here; however, avoid being sidetracked into a productivity issue (how quickly it can be done) rather than a quality issue of how long it takes to do it right the first time (with zero defects).
- ❑ Using best practices and accepted industry standards, appropriate times can be allocated for each performance guideline.

### 34.8.2 Risk Assessment

Next, perform a relative risk assessment of all the services.

- ❑ This risk assessment needs to be performed from an overall business perspective, rather than from a facility perspective.
- ❑ It may be as simple as a subjective grading of high-medium-low risk, or it may involve establishing evaluation criteria with weighed factors on such issues as:
  - strategic business alignment
  - liability exposure
  - internal culture
  - security clearance
  - operationally critical processes

### 34.8.3 Skills and Capabilities Assessment

Next, perform a skills and capabilities assessment.

- ❑ This is best performed by a quality improvement team that can objectively decide if the required skills exist internally or externally.
- ❑ Another decision that can be made here is whether to embark on a training program to improve in-house skills (if they are deficient), or whether external work suppliers can provide greater benefits.

### 34.8.4 Grouping Facility Services

Next, decide how the facility services will be grouped—or if they will be grouped at all.

- ❑ Based on the volume of work, and the skills, capabilities, and relative-risk assessments, a methodology of combining certain tasks can be established.

- ❑ A fairly simple method is to group all low-risk, low-skill, and low-volume work together to establish “bundles” of work based on commonality. Several companies have decided to group all services together and consider them as one main bundle.
- ❑ The information gathered when bidding out services can be compared with the information gathered by benchmarking, to help establish what an organization’s performance capabilities are.

## Human Factors to Be Considered Related to Job Competencies

### Knowledge

- Methods of work
- Materials
- Machines and equipment
- Instruments and tools
- Organization
- Environment

### Psychology

- Concentration
- Fatigue
- Emotions

### Biomechanical

- Balance, coordination
- Full range of motion
- Sitting
- Standing
- Head
- Upper extremities
- Lower extremities

### Safety

- OSHA
- ANSI
- CDC
- GHS
- EPA

### Strength and Stamina

- Lift, carry, place, transfer
- Materials, objects, people
- Weight
- Height, width, length

### Sensory

- Vision
- Hearing
- Olfactory
- Skin
- Taste
- Speech

### Quality

- ISO
- Six Sigma

The importance of ergonomics to quality is that it defines the organization's safety-related human processes of production and services to meet quality goals for target markets. Internal to organizations, an ergonomic program recognizes that people, work methods, materials, machines and equipment, instruments and tools, organizational policies, and facilities are integral to quality controls success. These factors working together can positively integrate productivity, safety, and quality. Ergonomic interventions on these factors influence the workers' motivation and reduce fatigue and the likelihood of sustaining an occupational injury or illness. The mutual goals of interrelated ergonomic and quality programs are twofold: first, to manage the problem and processes involved in designing things for effective human use; and second, to create environments that are suitable for human living and work.

Notably, International Standards Organization (ISO) directive 9000-based quality assurance includes ergonomics. ISO defines a blueprint for ergonomic assurance systems. They are defined as a set of interrelated resources and processes that function in order to achieve objectives related to ergonomic design and use of products and processes. Therefore, to design according to ISO 9000 requires human factors understanding at the applied level. In ISO 9000 definitions, the study of human factors in engineering and design of systems is included. ISO 9001 and ISO 9004 quality system models have ergonomic principles in all 20 requirements. The current ISO 9001:9004 standard is presented in an ergonomic light. Ergonomics and quality are parallel goals. Human factors begin with the documentation and continuously improve with the implementation of a quality system.

An ergonomic workplace that integrates quality goals has competency-based job descriptions. Workers understand and execute job demands based on clear objectives on task requirements to a standard expectation in knowledge, psychology, biomechanics, sensory, strength and stamina, safety, and quality. When workers know what the job demands are, they can perform and continuously improve.

### 35.1 Quality Goals for Ergonomic Programs

- ❑ An ergonomic plan that integrates productivity, safety, and quality goals
- ❑ Competency-based job descriptions that define job demands by knowledge, psychology, biomechanics, sensory, strength and stamina, safety, and quality
- ❑ Job safety analysis for each job title
- ❑ Prioritization of risk management by high, medium, and low
- ❑ Administrative controls that include the coordination of engineering, accommodation, supervision, and training
- ❑ Outcomes based on increased reporting, analysis, and intervention:
  - reduction of occupational injury and illness
  - reduction of workers' compensation
  - reduction of accident costs
  - reduction of medical visits
  - reduction of absenteeism
  - improvement in productivity
  - improvement of safety
  - improvement of quality

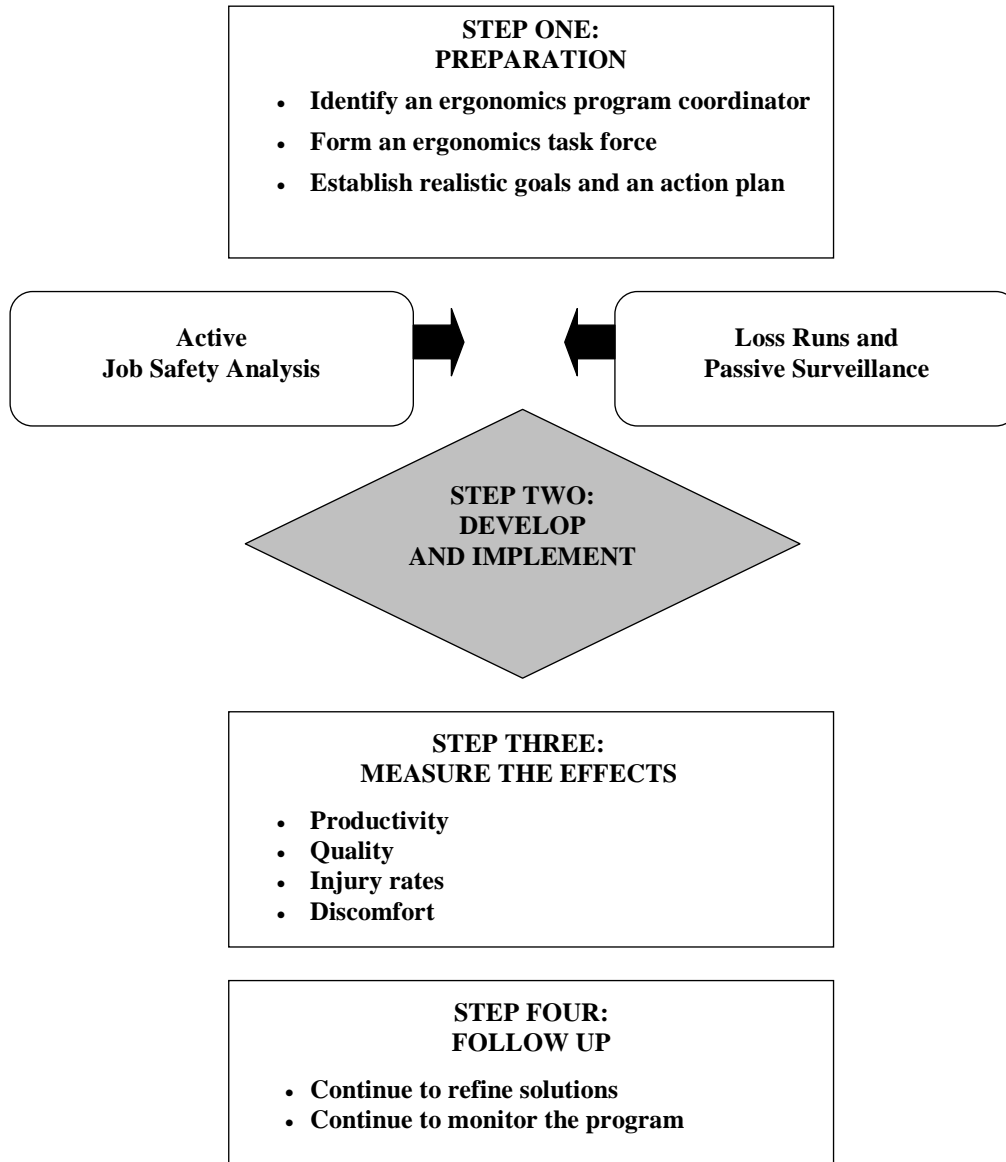

Figure 35.1. Quality and safety require a leadership plan to implement into productivity.

## 35.2 Quality Ergonomics Program

### I. Introduction

Our ergonomics program is committed to supporting our workers in their job demands as they interact with each other and their tasks, which involve the seven competencies of work. From a worker perspective we will support job demands of knowledge, psychology, biomechanics, sensory, strength and stamina, safety, and quality. We will support people in the work methods; with materials; using equipment, machines, instruments, and tools; with our organizational strategy and policies; in the environments of work. We will use the multidisciplines of industrial psychology, engineering, medicine, and design to create a quality ergonomic program.

We understand that ergonomics is the science of human factors and that comfort is a goal. We will strive to reduce musculoskeletal disorders (MSDs). To help avoid MSDs, we will design work demands to match physical capabilities of our workers. We will use engineering accommodation, supervision, and training to reduce:

- CTDs (cumulative trauma disorders)
- RSIs (repetitive stress or repetitive strain injuries)
- RMI (repetitive motion injuries)
- Overuse syndrome

NOTE: We recognize that the common, recognizable name for MSDs is cumulative trauma disorders or CTDs. These injuries belong to a family or group of wear-and-tear illnesses that can affect muscles, nerves, tendons, ligaments, joints, cartilage, blood vessels, or spinal disks of the body. MSDs do not include slips, trips, and falls; cuts; motor vehicle accidents or other similar accidents, although a close look at the reasons for acute injuries often reveals quality ergonomic design problems that can be corrected.

## II. Policy

It is our policy to provide all employees with a safe and healthful workplace. A proactive quality ergonomics program is integrated into our company's written safety and health program.

Our safety records document the identification, prevention, and control of employee exposure to ergonomic risk factors. They will be maintained pursuant to all regulations.

Our program is a collaborative effort that includes managers, supervisors, and labor. The ergonomics program coordinator is responsible for the program's implementation, management, and recordkeeping requirements.

## III. Ergonomics Program

The purpose of our ergonomics program is to apply ergonomic principles to the workplace in an effort to reduce the number and severity of MSDs, thus decreasing workers' compensation claims and, where possible, increasing productivity, quality, and efficiency. An ergonomically sound work environment maximizes employee comfort while minimizing the risk of undue physical stress.

Our proactive approach focuses on making changes when risks have already been identified, as well as incorporating ergonomics into the design phase of a new facility or process, into purchasing new equipment or tools, and into the contemplation of scheduling changes. This program includes the following components.

- A. **Management Leadership.** The management of (NAME OF COMPANY) is committed to the ergonomics process. Management supports the efforts of the ergonomics program coordinator and the ergonomics committee by pledging financial and philosophical support for the identification and control of ergonomic risk factors. Management will support an effective MSD reporting system and will respond promptly to reports. Management will regularly communicate with employees about the program.

- B. **Employee Participation.** As an essential element to the success of the ergonomics program, employees will be solicited for their input and assistance with identifying ergonomic risk factors, worksite evaluations, development and implementation of controls, and training. Employee participation in the program will occur only during company time.
- C. **Identification of Problem Jobs.** Collecting data that identifies injury and illness trends is called surveillance. Surveillance can be either *passive* or *active*. Conducting a records review is an example of passive surveillance, which looks at existing data such as OSHA logs, workers' compensation claims and trips to the medical facility, and absentee records. Active surveillance uses observations, interviews, surveys, questionnaires, checklists, and formal worksite evaluation tools to identify specific high-risk activities. (NAME OF COMPANY) will be using both passive and active surveillance to identify problem jobs.
- D. **Worksite Evaluations**
1. Triggers for a worksite evaluation:
    - When an employee reports an MSD sign or symptom
    - Jobs, processes, or work activities where work-related ergonomic risk factors have been identified that may cause or aggravate MSDs
    - Any change of jobs, tasks, equipment, tools, processes, scheduling, or changes in work shift hours (for example, going from a traditional five-day, 8-hour shift to a compressed four-day, 10-hour shift)
    - When a safety walk-through or scheduled inspection or survey has uncovered potential MSD hazards
  2. Work-related risk factors to be considered in the evaluation process include, but are not limited to:
    - Physical risk factors including force, postures (awkward and static), static loading and sustained exertion, fatigue, repetition, contact stress, extreme temperatures, and vibration
    - Administrative issues including job rotation/enlargement, inadequate staffing, excessive overtime, inadequate or lack of rest breaks, stress from deadlines, lack of training, work pace, work methods, and psychosocial issues
    - Environmental risk factors including noise, lighting, glare, air quality, temperature, humidity, and personal protective equipment and clothing
    - Combination of risk factors such as, but not limited to, highly repetitive, forceful work with no job rotation, or precision work in a dimly lit room

- E. **Setting Priorities.** Worksite evaluations will be scheduled based upon the following:
- Any job, process, operation, or workstation that has contributed to a worker's current MSD
  - A job, process, operation, or workstation that has historically contributed to MSDs
  - Specific jobs, processes, operations, or workstations that have the potential to cause MSDs
- F. **Worksite Evaluations Methods.** Various methods will be used to evaluate problem jobs including:
- Walk-through and observations
  - Employee interviews
  - Surveys and questionnaires
  - Checklists
  - Detailed worksite evaluations
- G. **Control of the Ergonomic Risk Factors.** We will take steps to identify ergonomic risk factors and reduce hazards by using a three-tier hierarchy of control (in order of preference):
- **Engineering controls.** The most desirable and reliable means to reduce workplace exposure to potential harmful effects. This is achieved by focusing on the physical modifications of jobs, workstations, tools, equipment, or processes. This includes the accommodation of workers.
  - **Administrative controls.** This means controlling or preventing workplace exposure to potentially harmful effects by implementing administrative changes such as job rotation, job enlargement, rest breaks, adjustment of pace, redesign of methods, and worker education. This includes the practice of supervision that role models and rewards safe actions.
  - **Personal protective equipment (PPE).** Not recognized as an effective means of controlling hazards and does not take the place of engineering or administrative controls. Acceptable forms of PPE include kneepads and various types of gloves including anti-vibration.
- H. **Training.** Training is intended to enhance the ability of managers, supervisors, and employees to recognize work-related ergonomic risk factors and to understand and apply appropriate control strategies. Training in the recognition and control of ergonomic risk factors will be given as follows:
- To all new employees during orientation
  - To all employees assuming a new job assignment

- When new jobs, tasks, tools, equipment, machinery, workstations, or processes are introduced
- When high exposure levels to ergonomic risk factors have been identified

The minimum for all managers, supervisors, and employees will include the following elements:

- An explanation of (NAME OF COMPANY) ergonomics program and their role in the program
- A list of the exposures that have been associated with the development of MSDs
- A description of MSD signs and symptoms and consequences of injuries caused by work-related and non-work-related risk factors
- An emphasis on the importance of early reporting of MSD signs and symptoms and injuries to management
- The methods used by (NAME OF COMPANY) to minimize work-related and non-work-related risk factors

Training will be provided in one, or in a combination, of the following formats:

- Oral presentations
- Videos
- Distribution of educational literature
- Hands-on equipment and work practice demonstrations

Trainers will be experienced in delivering training programs that address all work-related and non-work-related risk factors, and will be familiar with (NAME OF COMPANY) operations. Training will be provided from one, or a combination, of the sources listed below:

- Internally developed resources
- The workers' compensation carrier
- An outside consultant

All training will be documented: Employees will be required to sign a training sign-in roster.

#### I. MSD (Medical) Management and Early Return to Work.

Pursuant to the law, (NAME OF COMPANY) provides medical care to all employees injured at work. (NAME OF COMPANY) maintains a good working relationship with our medical care provider, (NAME OF MEDICAL FACILITY). All work-related injuries and illnesses will be referred to (NAME OF MEDICAL FACIL-

ITY) unless the injured employee has notified (NAME OF COMPANY) in writing that other provisions have been made prior to an injury or illness.

In the event of a work-related injury or illness, the health care provider/professional will:

- Provide diagnosis and treatment for employees
- Determine if reported MSD signs or symptoms are work-related
- Comply with our policy of early return to work program by recommending restricted, modified, or transitional work duties when appropriate
- Refer our injured employees to other clinical resources for therapy or rehabilitation
- Provide (NAME OF COMPANY) with timely work status reports
- Develop a positive working relationship with (NAME OF COMPANY) workers' compensation carrier, (NAME OF WORKERS' COMPENSATION CARRIER)

(NAME OF COMPANY) has an aggressive early return to work program and will offer return to work opportunities to all injured employees in accordance with work restrictions identified by a recognized medical provider.

#### J. Program Evaluation and Follow-Up

In order to ensure that issues have been addressed and that new problems have not been created, monitoring and evaluation will be conducted on an ongoing basis. The methods include use of individual interviews and checklists to reevaluate the job/task to ensure that risks have been reduced, minimized, or eliminated.

### IV. Individual Responsibilities

A. Ergonomics Program Coordinator. The ergonomics program coordinator will report directly to upper management and be responsible for this policy and program. All evaluations, controls, and training will be coordinated under the direction of the ergonomics program coordinator in collaboration with management. The ergonomics program coordinator will monitor the results of the program to determine additional areas of focus as needed. The quality and ergonomic program leadership is in this position. The ergonomics program coordinator quality concerns are to:

- Ensure that evaluators performing work site evaluations and training are properly trained
- Ensure that control measures are implemented in a timely manner
- Ensure that a system is in place for employees to report MSD signs or symptoms and suspected work-related risk factors to managers and supervisors
- Ensure that accurate records are maintained and provide documentation upon request

- Schedule manager, supervisor, and employee training and maintain records to include date, name of instructor, topic, and materials used
  - Monitor the program on a quarterly basis and provide an annual review
- B. Managers. Duties of all managers will include quality goals of:
- Accountability for the health and safety of all employees within their departments through the active support of the ergonomics program
  - Allocating human and/or financial resources
  - Attending ergonomics training to familiarize themselves with the elements of the program, recognition and control of work-related ergonomic risk factors, MSD signs and symptoms, early reporting requirements and procedures, and medical management
  - Ensuring that supervisors and employees have received the appropriate training
  - Ensuring that ergonomics practices and principles are considered when conducting worksite evaluations
  - Ensuring that recommended controls are implemented and/or used appropriately
- C. Supervisors. Duties of all supervisors will include ergonomic and quality goals:
- Attending ergonomics training to familiarize themselves with the elements of the program, recognition and control of work-related ergonomics risk factors, MSD signs and symptoms, early reporting requirements and procedures, and medical management
  - Ensuring that employees have received the appropriate training
  - Ensuring that employees are provided with and use the appropriate tools, equipment, parts, and materials in accordance with ergonomic requirements
  - Ensuring that employees understand the MSD signs and symptoms and early reporting system
  - Responding promptly to employee reports
  - Providing appropriate workers' compensation documentation to employees as required by all regulations
  - Seeking clarification from Human Resources when return-to-work directives from the healthcare provider/professional are unclear
  - Maintaining clear communication with managers and employees
- D. Employees. Every employee is responsible for conducting himself or herself in accordance with this ergonomic and quality policy and program. All employees will:

- When provided, use the appropriate tools, equipment, parts, materials, and procedures in the manner established by managers and supervisors
- Ensure that equipment is properly maintained in good condition and when not, reported immediately
- Attend ergonomics training as required and apply the knowledge and skills acquired to actual jobs, tasks, processes, and work activities
- Report MSD signs or symptoms and work-related MSD hazards to the supervisor as early as possible to facilitate medical treatment and proactive interventions
- Take responsibility for their personal health and safety

#### V. Annual Program Review

The ergonomics program coordinator will conduct an annual program review to assess the quality progress and success of the program. The review will consider the following quality goals:

- Competency-based job descriptions that define knowledge, psychology, biomechanics, sensory, strength and stamina, safety, and quality demands.
- Job safety analysis that validates risk
- Intervention strategies that consistently integrate engineering and administrative controls, accommodation, supervision, and training
- Evaluation of all training programs and records as current and related to safety competencies
- The need for retraining of managers, supervisors, and employees
- The jobs, processes, or operations that have produced a high incidence rate of work-related MSDs have risk management goals
- The length of time between a request for an ergonomic evaluation and the actual evaluation
- The length of time between the point at which the results of the evaluation are known and when implementation of controls begins
- The length of time between the beginning and completion of implementation of controls

The program's success based upon comparison to previous years using the following criteria:

- Number and type of lost workdays associated with OSHA recordable cases
- Cost of workers' compensation cases
- Employee feedback through direct interviews, walk-through observations, written surveys and questionnaires, and reevaluations of job safety analysis
- Consistency of return-to-work success
- Consistency of accommodations with Americans with Disabilities Act, 1990
- Increase of job safety analysis and documentation

## Human Factors to Be Considered Related to Job Competencies

### Knowledge

- Methods of work
- Materials
- Machines and equipment
- Instruments and tools
- Organization
- Environment

### Psychology

- Concentration
- Fatigue
- Emotions

### Biomechanical

- Balance, coordination
- Full range of motion
- Sitting
- Standing
- Head
- Upper extremities
- Lower extremities

### Safety

- OSHA
- ANSI
- CDC
- GHS
- EPA

### Strength and Stamina

- Lift, carry, place, transfer
- Materials, objects, people
- Weight
- Height, width, length

### Sensory

- Vision
- Hearing
- Olfactory
- Skin
- Taste
- Speech

### Quality

- ISO
- Six Sigma

The importance of ergonomics to recycling operations/centers is to reduce the risk that occurs due to inconsistencies in pickup/unloading, sorting, and material handling. Picking up loads varies by load and place (shredded paper in wastebaskets). Unloading varies by load shift and place (glass vials of biohazard in laboratories). Recycling activities can occur inside a facility or outside in all weather conditions. Recycled material has ergonomic stressors because they are most likely not uniform in type, shape, communicable disease, cleanliness, or size. Load containment also varies (weight-bagged or binned). And deposit stations vary by accessibility. Sorting can be challenging. Aluminum cans may be smashed, have sharp edges, and be full of ants. Cardboard may be wet and heavy. Glass may be in shards. Plus, undesirable materials, such as old computer equipment and car batteries, are often deposited in open-air bins.

In essence, the physical demands of recycling have a range that makes a best-fit match of worker competencies very broad. Notably, recycling workers in entry-level jobs tend to be younger and tend to underreport discomfort. The goal of ergonomics for recycling operations is to increase safe actions that create process improvements. This increase in predictability of the materials can reduce the risk of overextension.

### 36.1 Ergonomic Design Benefits

- Improved productivity
- Improved safety
- Improved quality
- Legal compliance

### 36.2 Consequences of Not Using Ergonomic Design

- Lost time
- Legal citation
- Injury, illness
- Disease
- Fatality
- Lost quality

### 36.3 Improving the Match of Worker Capabilities to Methods of Work

- Define the job by competencies for knowledge, psychology, biomechanics, sensory, strength and stamina, safety, and quality.
- Validate job demands by intensity of requirements (common sense to expert).
- Conduct job safety analysis.
- Validate job demands by frequency and severity of risk.
- Prescreen.
- Prescreen workers at each stage of employment.
- Screen for essential functions that may be validly compromised by age, disease, disability, or injury.
- First hired, lateral moves, promotion, return to work.

- ❑ Job safety analysis factors may dictate screening for human factors consequences, PPE, and competence to take safe actions (not all inclusive).
- ❑ Biomechanical:
  - stand and balance
  - grip to sort with fine motor
  - climb ladders and in and out of truck
  - foot flexibility with friction coefficient on indoor and outdoor surfaces
- ❑ Sensory:
  - hearing: acuity to distinguish machines (bailer grinding) sounds
  - vision: acuity to distinguish objects in darkened places
  - smell: acuity to determine toxic or dangerous smell in confined spaces
  - sensation: acuity to distinguish moving objects through gloves, as in vermin

## ***Make Recycling Easy!***

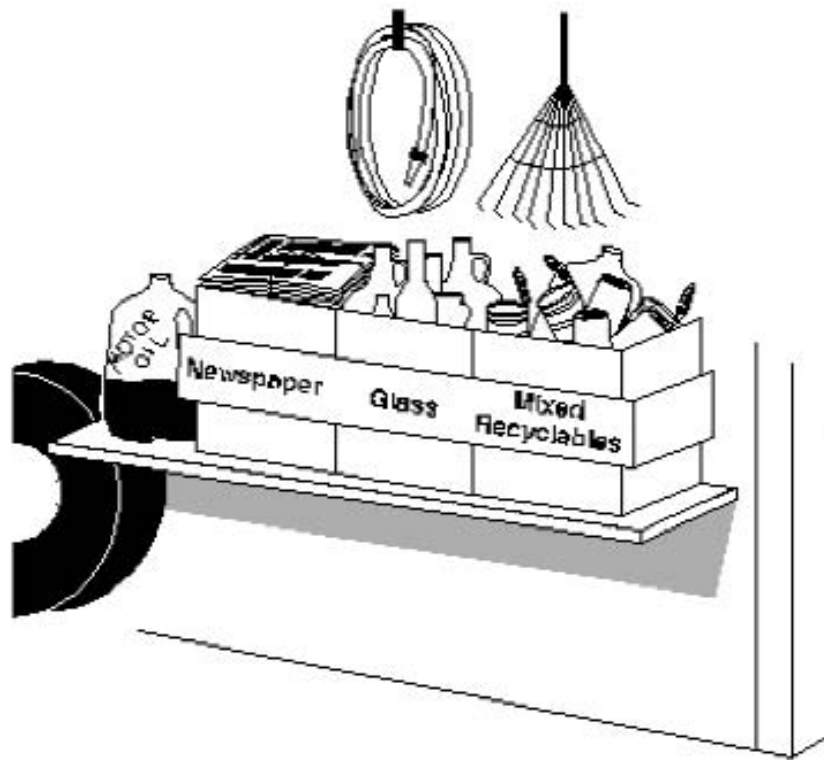

Figure 36.1. Recycling is easy if it is organized.

### 36.4 Improving the Methods of Work

- Integrate the knowledge, psychological, safety, and quality competencies of business requirements with the physical and sensory demands.
- Physical: Coordinate and cross-train workers on indoor recycling and outdoor recycling.
- Reduce over-shoulder lift and throw
- Sensory: Provide access lights to bins where consumers have free access to avoid exposure to unanticipated creatures (bees, snakes, rats, etc.) and objects.

### 36.5 Improving the Materials of Work

- Purchase bagging materials that do not break or puncture.
- Make sure tie-downs work under all weather conditions and do not require excessive manual dexterity in extremes of cold.

### 36.6 Improving the Equipment and Machines of Work

- Service bailers so that jams are infrequent.
- Use conveyor systems to feed the bailers.
- Create solutions that increase automation.

### 36.7 Improving the Instruments and Tools of Work

- Purchase ergonomic instruments and tools for tasks like shrink-wrap or tie-offs.

### 36.8 Improving the Organization of Work

- Optimize work processes to eliminate oversized materials.
- Integrate recycle stations in the right work areas.
- Eliminate hand sorting.

### 36.9 Improving the Environment of Work

- Design recycle stations to maximize the right material to the right bins.
- Design collection, grading, and sorting of waste or scrap to sort recycle or waste disposal.
- Place containers where the waste is produced to ease disposal and collection.
- Signage is the key to work areas with clear labels with pictures of glass, plastic, scrap, etc.
- Design in passage areas for personnel to bring materials directly to work area such as cardboard to the bailer, cans to the compressor, shredded papers to the compressor.

## Human Factors to Be Considered Related to Job Competencies

### Knowledge

- Methods of work
- Materials
- Machines and equipment
- Instruments and tools
- Organization
- Environment

### Psychology

- Concentration
- Fatigue
- Emotions

### Biomechanical

- Balance, coordination
- Full range of motion
- Sitting
- Standing
- Head
- Upper extremities
- Lower extremities

### Safety

- OSHA
- ANSI
- CDC
- GHS
- EPA

### Strength and Stamina

- Lift, carry, place, transfer
- Materials, objects, people
- Weight
- Height, width, length

### Sensory

- Vision
- Hearing
- Olfactory
- Skin
- Taste
- Speech

### Quality

- ISO
- Six Sigma

The importance of ergonomics from local to global relocation is the link between worker job demands and the management of the people-to-product logistics strategies. Relocation logistics strategy is the science of evaluating the most cost-effective methodology of distributing goods to market while achieving service level objectives. It is important for companies to recognize that logistics strategy is a human factors management approach that requires multitasking the biomechanical demands of product-specific, customer-specific, location-specific job demands. People manage supply chains by industry. Each industry requires people who are dynamic in their knowledge of teams, biomechanics, safety, and quality competencies. Relocation strategies are logistics that are always evolving because of enterprise risk management.

Ergonomics provides the human factors analysis and data to achieve a clear, in-depth understanding of the most effective ways for workers to meet job demands. Ergonomics analyzes workers' multitasking fatigue points across more than one location. This allows for an account of when local job demands must meet timelines in national and global markets. Relocation strategies require cross-referenced understanding of worker diversity, products, customers, suppliers, and worker stress points in distribution centers that operate linked divisions in many countries. Taking into consideration the size of operations, supply chains are complex and transcend multiple departments. Ergonomics helps to make the most effective human factors decisions for operational demands, customers, and supply chain management. Ergonomics is an unbiased evaluation of your human resources matched with the relocation demands of an enterprise. This results in optimum worker performance and product relocation that does not break down.

### **37.1 Ergonomic Design Benefits**

- Improved productivity
- Improved safety
- Improved quality
- Legal compliance

### **37.2 Consequences of Not Using Ergonomic Design**

- Lost time
- Legal citation
- Injury, illness
- Disease
- Fatality
- Lost quality

### **37.3 Improving the Match of Worker Capabilities to Methods of Work**

- Define the job by competencies for knowledge, psychology, biomechanics, sensory, strength and stamina, safety, and quality.
- Validate job demands by intensity of the requirement (common sense to expert).
- Conduct job safety analysis.

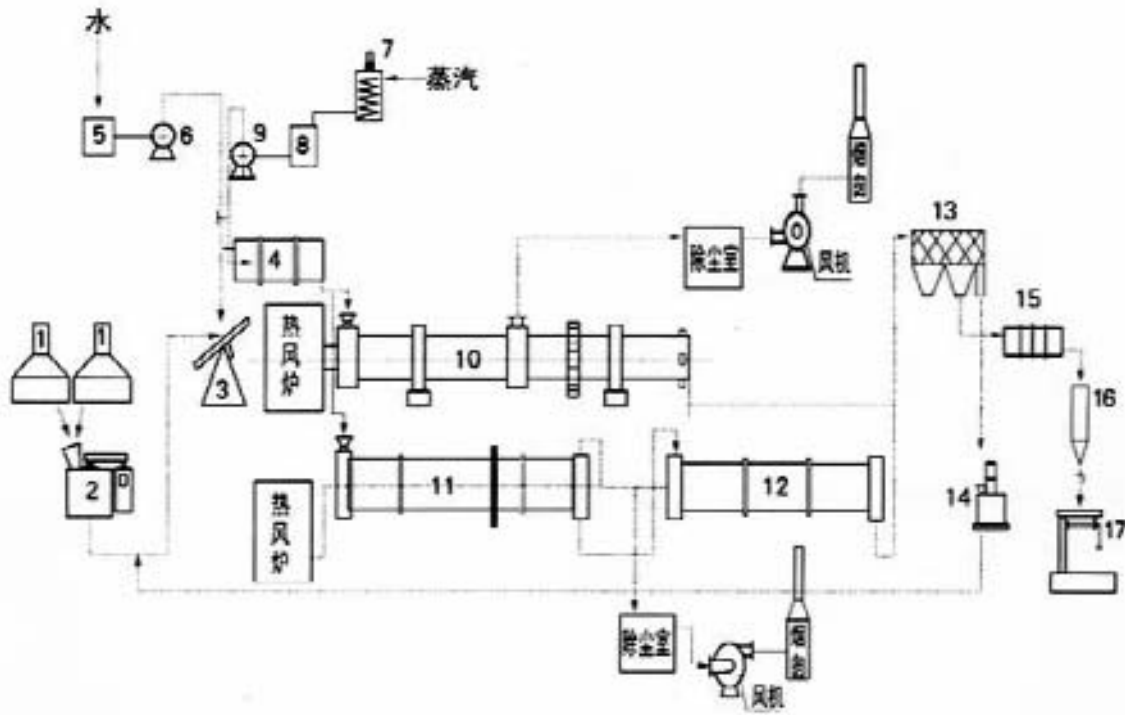

Figure 37.1. Relocation plan.

- Validate job demands by frequency and severity of risk.
- Prescreen.
- Prescreen workers at each stage of employment.
- Screen for age, disease, disability, and injury baselines related to the essential functions of the job.
- First hired, lateral moves, promotion, return to work.
- Job safety analysis factors may dictate screening for human factors consequences, PPE, and competence to take safe actions.
- Biomechanical:
  - multifunctional use of the body in static load seated positions and dynamic movements
- Sensory:
  - multitask coordination of senses
  - hearing: cross-cultural languages
  - vision: cross-cultural labeling

### 37.4 Improving the Methods of Work

- Integrate the knowledge, psychological, safety, and quality competencies of business requirements with the physical and sensory demands.
- Physical: Coordinate and cross-train workers on the integrated fit to multitask demands between product, computers.
- Develop the logistics strategy to handle fast-moving products differently from slow- and medium-moving products.

- ❑ Within your distribution center decide if it is ergonomically beneficial to set up regional “fast” facilities and a centralized “slow” facility.
- ❑ Create safe action protocols for high-strength vs. high-stamina tasks.
- ❑ Sensory: Set up work protocols to increase eye-hand and all sensory coordination (sight, hearing, touch, smell, taste) tasks with breaks to reduce repetition and duration of awkward postures and force.

### **37.5 Improving the Materials of Work**

- ❑ Develop a clear understanding of all of the ergonomic cost components and lost-profit opportunities for products that are deemed “direct store delivery” or “non-stock” items.
- ❑ Create a logistics strategy that clearly delineates when and how an item should be inventoried.
- ❑ Carry the right assortment and inventory levels to achieve service-level objectives and keep pick patterns to a minimum.
- ❑ Minimize inventory assets.
- ❑ Minimize storage and handling costs.
- ❑ Integrate the knowledge competencies of safe actions when relocating product to other locations.

### **37.6 Improving the Equipment and Machines of Work**

- ❑ Control the access points to hazards to reduce risk.
- ❑ Reduce human factors risks by analyzing landed cost of goods and improving inbound logistics strategy, including load consolidation, reduced handling, back-hauls.
- ❑ Reduce driver risks by reducing outbound transportation costs through:
  - improved private fleet routing
  - improved carrier rate shopping
  - load consolidation opportunities
- ❑ Create solutions that increase automation.

### **37.7 Improving the Instruments and Tools of Work**

- ❑ Increase your software management tools from bar coding to large inventory cycling.

### **37.8 Improving the Organization of Work**

- ❑ Optimize work processes with your trading partners to reduce supply chain complexities and improve service levels for specific products or vendor product lines.
- ❑ Rewrite internal supply chain policies that hinder cost-effective operations.
- ❑ Improve global logistics to reduce inventory levels in the supply chain.
- ❑ Reduce order cycle times.
- ❑ Reduce supplier lead times.
- ❑ Reduce logistics costs.
- ❑ Integrate safety stations in the right work areas.

### **37.9 Improving the Environment of Work**

- Optimize the work environment for both the mental and physical state of workers.
- Integrate accessibility, adaptability, density, design of space, housekeeping, lighting, passages, temperature, and training into safety components of relocation analysis and strategy.

## Human Factors to Be Considered Related to Job Competencies

### Knowledge

- Methods of work
- Materials
- Machines and equipment
- Instruments and tools
- Organization
- Environment

### Psychology

- Concentration
- Fatigue
- Emotions

### Biomechanical

- Balance, coordination
- Full range of motion
- Sitting
- Standing
- Head
- Upper extremities
- Lower extremities

### Safety

- OSHA
- ANSI
- CDC
- GHS
- EPA

### Strength and Stamina

- Lift, carry, place, transfer
- Materials, objects, people
- Weight
- Height, width, length

### Sensory

- Vision
- Hearing
- Olfactory
- Skin
- Taste
- Speech

### Quality

- ISO
- Six Sigma

The importance of ergonomics and robots (a programmed electrical mechanical machine) is that the time has come to expand and specify robotic design using safety principles and kinesthetic technology. Robots built on the master-slave model are destined for obsolescence. They are about to be replaced by a generation that will cooperate with man on a more equitable basis. It is critical to this new phase of robotics that safety managers and designers get on the same team and get the ergonomics right. This means that safety and design engineers build their partnership first. Then the man-and-machine partnership can be built on a clear understanding of what each does best, e.g., design robots for function and safety.

As more robots and humans work together, with increasing mobility and in many environments, it is key that we understand how to integrate humans into the equation of utility and safety. How well the robot and workers will get along is an essential safety design dimension. Of growing safety concern is the use of robots in nanotechnologies. This technology requires the synergy of ergonomics, robots, and design that uses safety principles and kinesthetic technology.

Robots and people used to get along by working parallel to each other on an assembly line with safety barriers. Now that is changing. Robots are becoming technology coworkers. They are becoming an extension of people's bodies and tasks. What this means is the engineering and architecture of the robot has to be defined beyond the graphic user interface requirement on a computer screen (GUI) to a robotic user (human) interface requirement (RUI). The RUI must be simple for the operator to understand and actuate, and easily aligned with safety. Simple to understand means the robot acts like and uses its senses just like a human. It may see, hear, and talk while it does its work. How the robot moves in coworker space, whether from a fixed position or a mobile one, is a critical RUI. Robots and people will not get along using the GUI and the RUI principles.

Ergonomic success is a human-to-robot design success. This requires specifying robotic interaction based on job safety analysis. For example, how the human moves and uses its senses for a lift, carry, and place is the dictum for how well the robot should be designed to move and use its sensors. How well the robot reacts to voice commands may be the critical intervention to our concept of "near miss." How the human controller speaks is factored in to job safety analysis. What if the robot can't hear a squeaky voice or a baritone due to an over 80-decibel environment? People using voice recognition systems have often had difficulty teaching the system to recognize their voice patterns. As robots move away from being our slave workers to becoming our coworkers we will need to "talk and be heard."

In safety management, specifically ergonomics, we must be able to assess and implement risk management that includes a new dimension of multitasking and robot interaction. Workers are a range of human performance that has peaks, fatigue, and distraction built into every day. So how does the safety professional begin? First, be prepared with a competency-based job description that has been validated for knowledge, psychology, biomechanics, sensory, strength and stamina, safety, and quality. Second, conduct a job safety analysis (JSA) that provides a databased risk summary that prioritizes the frequency and severity of risk. A JSA that is based on valid and reliable assessment data is the best design baseline for a positive result. Robots will help us in two ways if we use our data correctly: They can minimize risk and maximize

productivity in hazardous conditions. The ergonomics of workers and robot coworkers will succeed if we define the rules of engagement, e.g., interaction requirements.

### 38.1 Ergonomic Design Benefits

- Improved productivity
- Improved safety
- Improved quality
- Legal compliance

### 38.2 Consequences of Not Using Ergonomic Design

- Lost time
- Legal citation
- Injury, illness
- Disease
- Fatality
- Lost quality

### 38.3 Improving the Match of Worker Capabilities to Methods of Work

- Define the worker's job demands by competencies for knowledge, psychology, biomechanics, sensory, strength and stamina, safety, and quality.
- Validate the intensity of the requirement (common sense to expert).
- Define the robot's competencies by knowledge, psychology, biomechanics, sensory, strength and stamina, safety, and quality.
- Robots are quicker and more reliable than humans, but relatively inflexible. Humans are flexible but prone to errors, fatigue, memory lapses, and unreliability. If designers pay their dues to ergonomics, the human-robot partners of the future will complement each other's strengths and offset each other's limitations.
- Conduct job safety analysis.
- Validate worker job demands by frequency and severity of risk with special attention to the robotic interface. Ergonomically define postures, force, repetitions, durations, and excesses of temperature and vibration.
- Define the relevant questions:
  - How will the robot and workers biomechanically interact with what postures? Using what sensory awareness?
  - What is the proximity of risk?
  - How will workers use fine motor skills on required controllers?
  - Will this create hand fatigue like the mouse?
  - How will workers talk to the robot? Using voice commands?
  - How do you tell the robot to start or stop an action?
  - Can the robot anticipate the next action? Stop and stand still? Assume a neutral posture?
- Job safety analysis:
  - How will the robot move a part, material, or person?
  - Where will the person be?

- Where will the items and people be placed?
- Does the robot move using sensors?
- If the robot flashes, will that distract a worker?
- Prescreen workers to a match of robot management skills at each stage of employment.
- First hired, lateral moves, promotion, return to work.
- Screen for essential functions that may be validly compromised by age, injury, disease, or disability.
- Worker-required RUI of controllers
- Biomechanical
- Fine motor control
- A robot that is programmed is actuated by a worker using a controller that commands it to perform particular tasks, such as grasping an object.
- Balance
- RUI of worker senses and robot sensors
- A worker's peripheral vision will influence robotic placement providing the robot has a vision system that is sufficiently sensitive. If the robot understands sign language that will influence placement.
- Voice recognition specifies worker voice tone.
- Worker hearing is required to hear sequences of task complete alarms.
- Worker sensation and reaction time is critical to reframe robot actions in toxic or temperature-sensitive areas.

### 38.4 Improving the Methods of Work

- Integrate the knowledge competencies of business requirements with physical and sensory demands.
- Physical:
  - Coordinate and cross-train workers on static and dynamic postures of the robot relative to their work actions. Using a controller to manipulate robot mobility may be as challenging to the worker as the transitions of a demanding terrain are to the robot.
  - Define the human factors of interaction to include what aspects of the robots' design could affect reduction of risk for workers. Robots can reduce toxic exposure; awkward postures in hostile spaces (water, freezers, war zones); and loss of coordinated movement of excessive duration.
  - Robots must be trained to compensate for human limitations.
  - Cross-training workers in the sequences of work demands include robot interface on multitasking aspects of work multimodal user interfaces or instruction schemes.
- Sensory:
  - In all sensory acuities, robots can be more efficient than humans. They can see in the dark, hear underwater, and feel higher and lower temperatures.
  - Voice recognition technology enables robot actions. Humans and robots need to communicate ergonomically—efficiently and without misunderstandings
  - Sensory interaction in real time for workers involves workers' senses and psychology. Robots will have to understand a person's speech and understand a

person's intentions. Example: "Help" in a loud voice is different from a request for help in a soft voice, or is it? When is "help" an emergency word, and in what tone?

### 38.5 Improving the Materials of Work

- ❑ Robots can be built to adapt and adjust to material loads that exceed human competencies for weight and dimension as well as the sensate stability of gripping surfaces (wet, cold, hot).

### 38.6 Improving the Robotic Interface to Equipment and Machines of Work

- ❑ Use 3-D design to simulate your robotic user interface.
- ❑ Cross-train in simulation sequences of work demands to include robot interface on aspects of other equipment functions such as transport functions.
- ❑ Use preventive maintenance plan for robots.
- ❑ Safe maintenance is essential in robotic safety. Issues to be reviewed are quick changeability of tooling and modular components that have a durability, weight, and low vs. high profiles of designs and flexibility.
- ❑ The design success of any robotics operation is too often narrowly perceived as *how* consistently its tooling grips, holds, moves, and releases.
- ❑ In manufacturing, this can mean moving and releasing a part that is heavy or awkward.
- ❑ In service industries, this can mean moving prepared food to customers, as in fast food restaurants.
- ❑ In health care, this can mean helping a patient move through a rehabilitation protocol.
- ❑ Design success includes primary and secondary operations such as indexing or rotation for positioning. An example would be putting an item into a material handling, shipping, or packaging container.
- ❑ Complicated operations make robotics a very complicated safety issue.
- ❑ Real design success should mean that there are safety gains and minimized liabilities. Therefore, safety professionals need to be proactive on design teams to champion prevention of occupational illness and injury involving robots.

### 38.7 Improving the Instruments and Tools of Work

- ❑ Quick changeability is a feature that should be built in. The tools should easily adjust and make quick EOAT (tooling) changes.
- ❑ A quick-change chuck permanently attached to the side of the robot allows EOAT to be affixed to a dovetail that slides in and out of the chuck.
- ❑ All air connections are then made to the chuck via quick-touch connectors (no hand tools are required).
- ❑ The ability of robots to repair themselves may ultimately lead to more sustainable human-robot environments that do not require humans to constantly support the machines.



**Figure 38.1.** Robots mimic the range of motion of their human co-workers.

### 38.8 Improving the Organization of Work

- ❑ Robots are electrical, mechanical machines that are programmed with software. That creates their dynamic actions. The newest dynamic is partnering with human workers.
- ❑ Partnering a robot and a worker for a defined task, such as a construction job, will require the ability of each entity to work cooperatively. Long-term, this means the ability of the robot
  - to understand people’s explanation of goals, beliefs, and plans
  - to negotiate both physical-interactive and strategic ways of working together
- ❑ It will therefore be necessary to have robotically interactive systems with people who when they give commands are understood by robots who interpret commands intelligently.
- ❑ Long-term partnering robots must be able to adapt to unexpected circumstances, especially when people are not supervising.

### 38.9 Improving the Environment of Work

- ❑ Integrate air quality, density, design of space, interplant transfer, lighting, passages, security, and signage as components of robotic ergonomics.
- ❑ The environmental design starts with determining what worker, robot, and physical plant functionality to emphasize.

- Robots might be required for
  - heavy lifting or transporting loads
  - working in areas deemed unsafe for humans
  - exploring and surveying
  - or simply for working alongside humans on certain tasks
- Each function amounts to a different technical challenge involving mobility and people:
  - ability to travel over given topography
  - planning and adapting to a traverse of terrain obstacles
  - route finding
  - physical interaction in real time with people

## Human Factors to Be Considered Related to Job Competencies

### Knowledge

- Methods of work
- Materials
- Machines and equipment
- Instruments and tools
- Organization
- Environment

### Psychology

- Concentration
- Fatigue
- Emotions

### Biomechanical

- Balance, coordination
- Full range of motion
- Sitting
- Standing
- Head
- Upper extremities
- Lower extremities

### Safety

- OSHA
- ANSI
- CDC
- GHS
- EPA

### Strength and Stamina

- Lift, carry, place, transfer
- Materials, objects, people
- Weight
- Height, width, length

### Sensory

- Vision
- Hearing
- Olfactory
- Skin
- Taste
- Speech

### Quality

- ISO
- Six Sigma

The ergonomic importance of safety is to reduce occupational illnesses and injuries by reducing the risks of accidents. An accident reduction strategy should include prevention strategies, such as prevention of accidents involving stored energy (electricity, torque, and chemicals). In addition, ergonomic plans should modify the rate of spatial distribution of energy in material handling by recommending appropriate equipment (e.g., better catwalks to access machines) and space divisions to locate resources closer to areas of use. Safety evaluations should include measuring the energy used in a space between people or inanimate objects. Safety evaluations should also consider what potential damage by people or damage to people could occur, such as the danger of slings that are used when frayed.

Safety interventions include modification of contact surfaces and pinch points to prevent cuts, splinters, and bruises; strengthening the susceptible physical body with the correct use of PPE such as eyewear, hearing protection, and properly fitting gloves; minimizing the extent of loss or damage by immediate care for injured workers and maintenance of critical systems (fire sprinkler system and extinguishers); and developing an immediate rehabilitation and light-duty response to follow injuries, prevent lost time, and prevent damage.

### 39.1 Ergonomic Design Benefits

- Improved safety
- Legal compliance

### 39.2 Consequences of Not Using Ergonomic Design

- Lost time
- Increased cost
- Injury, illness
- Disease
- Fatality
- Legal citation
- Lost quality

### 39.3 Ergonomic Design

- Beyond OSHA, ergonomic design should include fire protection, safety and water, safety of personnel, and environmental compliance.

### 39.4 Fire Protection

- The requirements for fire protection systems are stipulated in detail by local building codes. Most local codes are based on the model codes and recommendations of the National Fire Protection Association. As a result, model code information can safely be used to establish preliminary design budgeting.
- To correctly interpret the many model building code requirements and establish costing parameters, the building must first be classified. The following information is required to do so:

- fire zone
- occupancy group
- type of construction
- location of property
- number of occupants
- floor area

- With this information, systems can be purchased within the estimated budget. It is also important to review local code requirements to assess their impact on cost.

#### 39.4.1 Standpipes

- In buildings where water may be used as the extinguishing agent, standpipes are often used to carry the water in large diameter pipes throughout the building.
- There are three standpipe systems that are recognized by the model codes: dry, wet, and combination.
- Costing is based on building classification, number of floors, and floor-to-floor height.

#### 39.4.2 Sprinklers

- Automatic sprinkler systems have been in use for many years in buildings as a very effective means for controlling and even extinguishing fires that are in the early stages.
  - Being automatic, these systems do not require building occupants to activate them.
  - The flow of water is comparable to a heavy rainfall.
- The model codes require automatic sprinkler systems in some buildings. In others, they are highly recommended. The most common types are:
  - wet pipe
  - fire cycle
  - dry pipe
  - preaction
  - deluge
- Sprinkler costing is based on building classification, floor area, and floor level.

#### 39.5 Minimal Administrative Policies

- Safety training is required for all supervisors and employees.

#### 39.6 Other Recommended Programs and Policies

- Accident prevention program
- Lockout/tagout program
- Respiratory protection program
- Hearing conservation program
- Chemical hygiene plan
- Hazard communication program
- Confined space program

## The Integrated Safety Management System

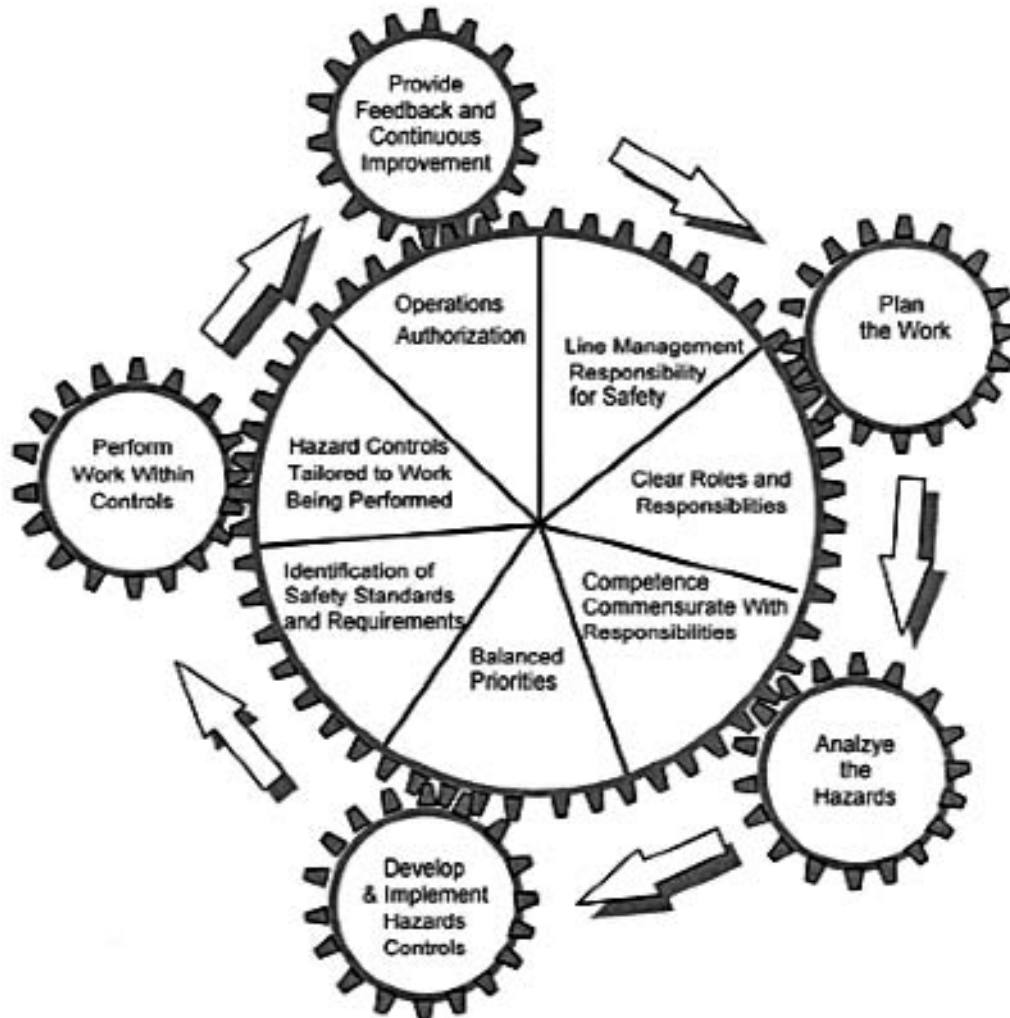

Figure 39.1. Integrated safety management system.

- Emergency action plan
- Safety and health program
- Preventive maintenance program
- Assured equipment grounding conductor program
- Housekeeping plan
- Crane and derrick safety manual
- Medical surveillance program
- Ergonomics program
- Infection control program

- Written operation plan for emergency situations
- Bio-safety manual
- Work practices program
- Programs to comply with all substance-specific OSHA laws
- Programs for any other OSHA rule or state law that requires employers to adopt a written program

### 39.7 Safety of Personnel

- Safety programs protect operating personnel and property from preventable hazards.—An example safety problem is refrigerant toxicity and flammability and potentially hazardous operating pressures and temperatures.

#### 39.7.1 Applicable Standards

- Occupational Safety and Health Administration's (OSHA) 29 CFR Standards
- 29 CFRs 1910 and 1926
- American Society of Heating, Air Conditioning
- Refrigerating Engineers (ASHARE) Standard 15 (Safety Code for Mechanical Refrigeration)
- Standard 34 (Number Designation and Safety Classification of Refrigerants)

#### 39.7.2 Essential Refrigerant Safety Program Aspects

- Material Safety Data Sheets (MSDSs) for documentation
- Chiller room sensing devices (refrigerant vapor detector/oxygen deprivation sensor)
- Sensor-activated alarm and ventilation system
- Self-contained breathing apparatus
- Automatic ventilation refrigerant evacuation system
- Relief and purge outdoor discharge piping
- Safe handling procedures for refrigerants
- Safe usage of recovery and reclaiming equipment
- General machinery room safety compliance
- General O & M safety awareness and practices

### 39.8 Environmental Compliance and Safety

What should environmental compliance include? Here are several relevant areas of interest at a typical non-manufacturing facility:

- Past history of environmental investigations or actions at the site (soil cleanups, asbestos abatement, interior air quality survey)
- Site conditions (topography, land use, geology)
- Potential problems from adjoining or nearby sites
- Underground or aboveground storage tank
- PCBs (transformers, capacitors, etc.)
- Asbestos-containing materials
- Air emissions from copying machines, print shops, etc.

- Sanitary or stormwater discharges
- Registration of combustion equipment such as boilers and emergency generators
- Compliance with CFC regulations for maintenance and operation of air conditioning equipment
- Storage, use, and disposal of paints, solvents, batteries, and other hazardous materials
- Lead paint or lead in drinking water
- Interior air quality (IAQ) problems

### 39.9 Safety and Water

- Specify water purification systems for drinking fountains, break rooms, and cafeterias. These systems should be restaurant-quality purification units with replaceable cartridges.
- Water purification units should:
  - remove common off-tastes and odors, such as chlorine
  - filter suspended particles as small as 0.5 microns
  - reduce mineral and scale deposits in ice machines, coffee makers, and soda dispensers, reducing maintenance and increasing machine life

## Human Factors to Be Considered Related to Job Competencies

### Knowledge

- Methods of work
- Materials
- Machines and equipment
- Instruments and tools
- Organization
- Environment

### Psychology

- Concentration
- Fatigue
- Emotions

### Biomechanical

- Balance, coordination
- Full range of motion
- Sitting
- Standing
- Head
- Upper extremities
- Lower extremities

### Safety

- OSHA
- ANSI
- CDC
- GHS
- EPA

### Strength and Stamina

- Lift, carry, place, transfer
- Materials, objects, people
- Weight
- Height, width, length

### Sensory

- Vision
- Hearing
- Olfactory
- Skin
- Taste
- Speech

### Quality

- ISO
- Six Sigma

The ergonomic importance of security is to consider the personal safety of employees in the workplace. The critical link of stress to increased workplace violence is well documented. Security relates to ergonomics, then, in the design of protected and secure spaces that reduce the stress to workers who may feel in danger or become endangered. The physical space of a workplace should create perceived zones of personal safety. It is now very common practice to have limited access areas for workers who often work alone, either very late or in the very early morning hours. These workers also often request escorts when entering and leaving their work areas. Designs incorporate surveillance opportunities to “lonely” areas. The best surveillance opportunity is to watch spaces that are in the truncated U shape (as in looking over a balcony into a large lobby), versus spaces that form a long rectangular (as in offices with hundreds of panels forming office cubicles.) Safe zones should be reviewed with all workers to promote the relationship between worker safety and security.

#### 40.1 Ergonomic Design Benefits

- Improved safety
- Legal compliance

#### 40.2 Consequences of Not Using Ergonomic Design

- Lost time
- Increased cost
- Injury, illness
- Disease
- Fatality
- Legal citation
- Lost quality

#### 40.3 Security Inspections

- Competent supervision and the ability to respond quickly and effectively to security needs are critical to maintaining high morale and effective security service.
- Experienced field officers and local management should supervise security officers on the site. Educational level and experience are important.
- Training should be specific to the site.
- Detailed regular inspection documentation should be provided.
- Security officers should be inspected each day.
  - A daily report from each security officer, and special reports of unusual incidents observed by a security officer, should be submitted.
- On-site inspections should be conducted once a month at random by regional field officers or executive management.
- For a service problem, a response team from the security vendor should provide quick access to the complete chain of command, ranging from the on-site supervisor to corporate headquarters.

#### 40.4 Security Services

- General investigations (overt or covert)
- Background screening of potential new employees
- Kidnapping and ransom insurance
- Security coverage for computers
- Security surveys of new facilities
- Preparation of a comprehensive security manual
- Electronic audio countermeasures sweeps
- Special publications of the latest prevention techniques
- Rapid development of strike or emergency personnel
- Anti-terrorist consulting
- Safety consulting
- Specialized personnel to support a broad range of security management activities
- Workplace violence consulting



**Figure 40.1.** Security can be electronically managed.

## 40.5 Security Considerations on Smart Cards

- ❑ Smart cards are able to carry larger amounts of information, more than magnetic stripe cards. Smart cards provide the opportunity to make machines much more user-friendly than they have ever been.
- ❑ For disabled workers and elderly people, a smart card can carry information that tells a terminal to allow the user more time.
- ❑ Smart terminals should allow elderly workers and those with cognitive impairment the time to think.
  - People make mistakes when they fear being “timed out” by the machine.
  - It is necessary to allow such people to use the terminal at their own pace.
- ❑ Simplify the choices such as issuing a preset code.
- ❑ Use larger characters for people with low vision on cards and terminals.
- ❑ Use audio output of non-confidential instructions and information.

## Human Factors to Be Considered Related to Job Competencies

### Knowledge

- Methods of work
- Materials
- Machines and equipment
- Instruments and tools
- Organization
- Environment

### Psychology

- Concentration
- Fatigue
- Emotions

### Biomechanical

- Balance, coordination
- Full range of motion
- Sitting
- Standing
- Head
- Upper extremities
- Lower extremities

### Safety

- OSHA
- ANSI
- CDC
- GHS
- EPA

### Strength and Stamina

- Lift, carry, place, transfer
- Materials, objects, people
- Weight
- Height, width, length

### Sensory

- Vision
- Hearing
- Olfactory
- Skin
- Taste
- Speech

### Quality

- ISO
- Six Sigma

Signs impact every aspect of job routines from informational (e.g., “Parking”) to instructional (e.g., “Keep Guard Down”) and are critical to maintaining safety (e.g., “Catwalk Off Limits”). Signs use visual, symbolic codes to communicate information. Well-designed signs directly convey their meaning. An example is a sign that forbids pedestrian traffic on a path intended for forklifts—a round sign with a line through the worker on the path denotes that the walkway is not for workers. An optimal sign does not have to be recoded or explained. Signs should be standardized throughout the organization to mean exactly the same thing wherever they appear. Signs should be relevant to the worker so that they are not ignored. Signs should always be placed in the visual field of all workers.

#### 41.1 Ergonomic Design Benefits

- Improved safety
- Legal compliance

#### 41.2 Consequences of Not Using Ergonomic Design

- Lost time
- Increased cost
- Injury, illness
- Disease
- Fatality

#### 41.3 Legibility

- Use appropriate materials and methods for designing labels for specific environmental conditions. For instance, engraved labels should not be used in areas where dirt and debris might fill in the engraving.
- Proper protective coating of paper labels should be applied where corrosive chemicals or high abrasion are present.
- Labels may be made of other durable materials, including Tyvek or plastic.
- Install labels where they will not be damaged by routine operating or maintenance procedures.
- Labels inserted into permanently attached fixtures are preferable to those attached directly to equipment or walls. This makes labels easy to change as procedures and equipment change.
- Mount labels at an appropriate angle and use non-shiny materials to avoid glare, reflection, and shading.
- Tools or control devices requiring engraving on curved metal surfaces should have anodized surfaces to reduce spectral glare.
- Plan labeling for curved surfaces (such as piping on metal drums) so that all the lettering is readable from one viewing location.
- Use a border to improve readability of a single block of numbers or letters. Keep embellishments to a minimum. If several labels are clustered in the same area, put distinctive borders around the critical ones only.
- Use simple and decipherable typefaces.

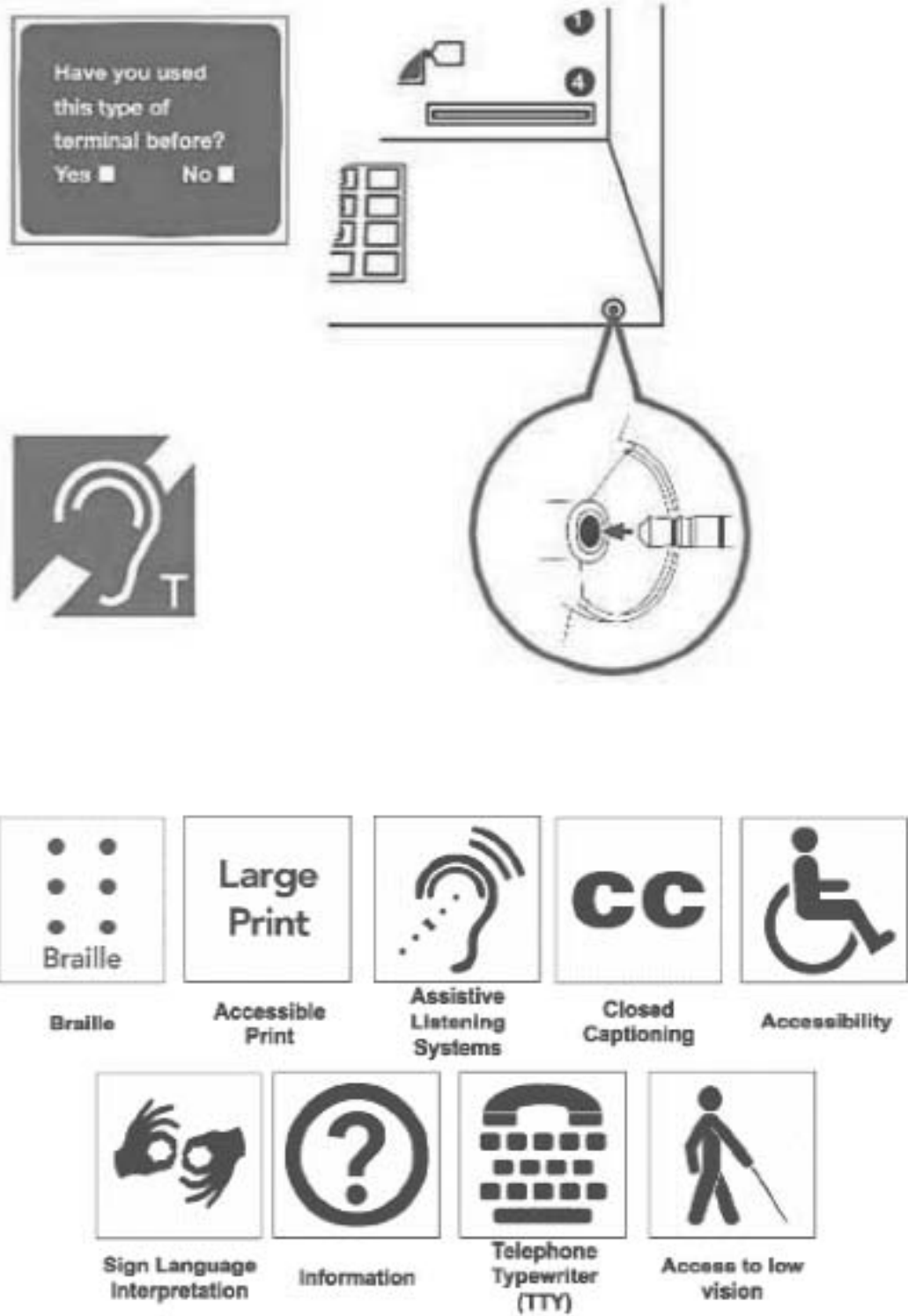

Figure 41.1. Signage should guide safe actions.

- ❑ Use all capital letters for headings or messages of a few words only.
  - Use uppercase and lowercase letters for longer messages.
  - Limit the use of *italics* to the emphasis of specific words or short phrases.
  - An alternative method for emphasis is underlining.
- ❑ The minimum spacing between characters should be one stroke width.
- ❑ If a label is more than 79 inches above the floor where people are standing or sitting, character height should be increased in relation to width.
- ❑ Avoid the use of multicolored lettering. If colored print must be used in order to take advantage of color-coding, legibility may be reduced.

In normal light conditions (>10 foot-candles), letter and number size should follow these guidelines:

- ❑ Stroke width should be 1/6 of the letter height for black letters or numbers on a white background.
- ❑ Letter width should be 3/5 of the letter height (except “I,” which should be one stroke width, and “M” and “W,” which should be 4/5 of the height).
- ❑ Number width should also be 3/5 of the number height (except “1,” which should be one stroke width).
- ❑ Characteristic features such as openings and counters should be obvious.
- ❑ The height is dependent on the viewing distance and the criticalness of the information.
- ❑ In reduced-light areas (such as darkrooms), white letters on a black background are most visible. In this case, the stroke width should be 1/8 of the height.

#### 41.4 Abbreviations

- ❑ Avoid abbreviations. If they must be used, use standard abbreviations.
- ❑ If a standard abbreviation does not exist, test the new abbreviation on inexperienced people to determine its understandability.

#### 41.5 Information Coding

- ❑ Coded information is widely used in production systems. Some examples of coded information are:
  - lot numbers
  - part numbers
  - product identification numbers
  - invoice numbers
  - operation sequences
- ❑ These numbers and/or letters can easily be misinterpreted, resulting in errors. The basic types of errors are:
  - addition of characters
  - substitution of characters
  - transposition of characters

### 41.5.1 Information Coding Guidelines

Eastman Kodak Company, *Ergonomic Design for People at Work*, Vol. 1 (New York: Van Nostrand Reinhold, 1983), 174–175.

- Numeric codes are preferable to alphanumeric codes.
- Code length should not exceed four to five digits.
- If longer codes are necessary, the digits should be grouped in threes and fours and separated by a space or hyphen.
  - Poor: 1234567
  - Good: 123-4567
- If a numeric code system contains several digit sequences that occur very frequently, they should comprise the first or last section of the code.
  - Poor: 35957, 25952
  - Good: 59537, 59522
- In tabular listings, when a digit sequence occurs repeatedly at the start of many-digit numbers, only the last digits for subsequent entries should be printed.
  - Poor: 7580170, 7581010, 7582030, 7583040, 7584050, 7585060, 7591000
  - Good: 7580170, 1010, 2030, 3040, 4050, 5060, 7591000
- Alphanumeric codes should have the letters grouped together rather than interspersed throughout the code.
  - Poor: 7A8B4
  - Good: AB784
- Use a specific location for numbers and letters to help avoid look-alike substitutions.
- Avoid the letters B, D, I, O, Q, and Z and the numbers 0, 1, and 8 in alphanumeric codes.
- Numbers should be used in the last few positions of long alphanumeric codes.
- Where possible, use pronounceable words and syllables instead of random letters.
  - Poor: TGP32
  - Good: TAC32
- Use simple typefaces with clearly distinguishable characters.
- Use bold printing and high contrast for all codes on labels and displays.
- Avoid faded characters on a card or sheet, especially if they must be read under low light conditions.
- Use color combinations that make codes easy to read.
- Avoid using 0 or 6 in codes when extensive handwriting is required.
- Characters should not be obliterated by keypunch holes.

## Human Factors to Be Considered Related to Job Competencies

### Knowledge

- Methods of work
- Materials
- Machines and equipment
- Instruments and tools
- Organization
- Environment

### Psychology

- Concentration
- Fatigue
- Emotions

### Biomechanical

- Balance, coordination
- Full range of motion
- Sitting
- Standing
- Head
- Upper extremities
- Lower extremities

### Safety

- OSHA
- ANSI
- CDC
- GHS
- EPA

### Strength and Stamina

- Lift, carry, place, transfer
- Materials, objects, people
- Weight
- Height, width, length

### Sensory

- Vision
- Hearing
- Olfactory
- Skin
- Taste
- Speech

### Quality

- ISO
- Six Sigma

The importance of ergonomics to software development and software choices has increased in the last decade. Seventy percent of all jobs require some software interface. Therefore, difficult-to-use hardware and software computer interfaces are becoming increasingly perceived as a source of ergonomic stress. Ergonomics can increase usability and reduce stress from workstation postures, mouse repetitions, keyboard force, and work task duration. When dealing with human beings, perception, rather than fact, plays a large role in the way risk is viewed. It is well established that people's perception of the magnitude of risk is influenced by factors other than statistical data. This means that an office worker will attribute the cause of health problems to items of high-perceived risk, not necessarily high statistical risk. For example, a data entry worker may be inclined to attribute the cause of her stress to poor workstation design and not to a statistically equally likely cause of poor software design.

As a result of this, improving software usability is now becoming a key factor in the drive to reduce ergonomic stress in the workplace. Although no one would deliberately design software that was not suited for its purpose, there are often mismatches between the way the system operates and the way the user works. For example, in a telesales operation, the system should be designed to allow customer details to be entered in an order that is natural to the conversation. In some systems, users are forced to remember or note down transaction details out of order or waste time tabbing through inappropriate fields on the display.

The objective of ergonomic job safety analysis and intervention is to provide design requirements and recommendations that will increase the accessibility, learnability, and ease of software use. The ultimate beneficiaries of ergonomic job safety analysis are the end users of software. Their needs define the design recommendations. The application of ergonomics is intended to provide user interfaces that are more usable, accessible, and consistent. Ergonomics should enable greater productivity, safety, and quality. Unique to this section, a set of questions are tabled that prompt analysis of software functionality related to worker usability (user-friendliness). The questions are consistent with ISO standards and fair employment law practices, particularly the Americans with Disabilities Act, 1990.

### 42.1 Ergonomic Design Benefits

- Improved productivity
- Improved safety
- Improved quality
- Legal compliance

### 42.2 Consequences of Not Using Ergonomic Design

- Lost time
- Legal citation
- Injury, illness
- Disease
- Fatality
- Lost quality

### 42.3 Improving the Match of Worker Capabilities to Methods of Work

- ❑ Define the job demands by competencies for knowledge, psychology, biomechanics, sensory, strength and stamina, safety, and quality.
  - Validate job demands by intensity of the requirement (common sense to expert).
- ❑ Conduct job safety analysis.
  - Validate factors by frequency and severity of risk.
- ❑ Prescreen workers.
  - Industry specific testing, task simulation.
  - Prescreen workers at each stage of employment.
  - First hired, lateral moves, promotion, return to work.
- ❑ Job safety analysis guides screening for human factors consequences related to the Americans with Disabilities Act. Since the accommodation to chronic impairments workers may include software, it is important to understand the range of qualified disabilities and match screening to them. Be prepared to justify required worker competencies to your software-related job demands.
- ❑ Physical and sensory screening (examples)
  - biomechanical: multifunctional use of the body in static load seated positions at a computer workstation
  - sensory: multitask coordination of senses; near-sighted vision to the computer screen and color-coded data

### 42.4 Improving the Methods of Work

- ❑ Integrate the knowledge, psychological, safety, and quality competencies of business requirements with the physical and sensory demands.
- ❑ Ergonomically, methods of work using software improve when
  - software is suitable for the task
  - software is easy to use and, where appropriate, adaptable to the user's level of knowledge or experience
  - systems display information in a format and at a pace that are adapted to users
- ❑ Physical: Coordinate and cross-train workers on the integrated fit to multitask demands between data input and computers.
  - Create safe action protocols for computer workstations to increase comfort.
- ❑ Sensory: Set up work protocols to increase eye-hand and all sensory coordination (sight, hearing, touch, smell, taste) to software use.

**Table 42.1 ADA ranges of qualified disabilities**

<i>Code</i>	<i>Impairment</i>	<i>Rank of problem</i>
P:	Physical impairments	1. No significant problems
SP:	Severe physical impairments	2. Minor problems
V:	Impaired vision (inc. color blindness)	3. Moderate problems
B:	Blind persons	4. Severe problems
H:	Slight to moderate hearing impairments	
D:	Deaf (persons with profound to severe hearing impairments)	
C:	Cognitive impairments	
O:	Other (inc. left-handed, different language)	

**Table 42.2. Software and Assistive Technology***Software application*

- Is the application designed to minimize the number of steps required to activate any option?
- Does the application provide the end function?
- Does the operating system interface provide undo functionality?
- Can user preferences be customized?
- Can user preferences be used across locations?

*Object information*

- Is there a well-defined on-screen indication of the current focus?
- Is semantic information about user interface objects provided?
- Are labels associated with controls, objects, icons, and images?
- If electronic forms are used, are people using assistive technologies allowed to use the forms?
- Does the OS provide text or sign language- and finger spelling-based help systems?
- Is the application menu and window navigation circular?
- Is event notification available to assistive technologies?
- Are object attributes available to assistive technologies?
- Are implicit designators (underlined letters in menus, buttons) provided?

**42.5 Improving the Materials of Work**

- Data entry is often driven by forms used. (See Legibility of Forms.)

**42.6 Improving the Equipment and Machines of Work**

- Assertive technologies should increase efficiency of hardware and peripherals such as keyboards with software.

**42.7 Improving the Instruments and Tools of Work**

- Integration of hardware and software with user interfaces can be related to accommodations for the disability as well as to job competencies, such as for a person who is deaf using speech to text software to their own BlackBerry or similar device.
- Increase your software management tools. Ask:
  - Is the dialogue simple?
  - Does the interface speak the users' language?
  - Does the interface minimize the users' memory load?
  - Is the interface consistent?
  - Is feedback visible?
  - Are the exits clearly marked?
  - Do shortcuts exist?
  - Are the error messages explicit?
  - Are there means to prevent the errors?
  - Does an online help exist?
  - Is the software documented?

**Table 42.3. Computer Assistive-Technology Options***Assertive technologies*

- Do the applications avoid disrupting or disabling activated features of other products that are identified as accessibility features?
- Do the applications use system standard input/output?
- Does the operating system provide services for the applications to be accessible?
- Can the user select input/output devices?
- Can the user switch input/output alternatives?
- Can the user perform the task effectively with any single input device?
- Does the operating system provide user preference profiles?
- Do the applications provide navigation to task-appropriate groups of controls?
- Does the applications system retain input focus?

*Keyboard access*

- Are all the application functions (including navigation) accessible by keyboard?
- Is there a sequential alternative to simultaneous keyboard action?
- Does the application respect the operating system keyboard access conventions?
- Is the sequence for moving from one item to another in a dialogue box using the keyboard consistent with the screen layout?
- Does the application provide well-documented accelerator keys?
- Does the application avoid interfering with keyboard accessibility features built into the operating system?
- Can the keyboard functions be re-mapped?
- Is keyboard navigation separate from keyboard activation?
- Is there a method for distinguishing macro input from keyboard input?

*Pointing devices such as the mouse*

- Is the location of pointing device button functions adjustable?
- Is there the possibility to enable multiple clicks with single key press and release?
- Is there the possibility to enable button hold with a single button press and release?
- Can a delay of pointer button press acceptance be defined?
- Can a delay of pointer movement acceptance after mouse down be defined?
- Is the multiple-click interval and target area customizable?
- Is the speed of pointer movement customizable?
- Are there alternatives to chorded pointer-key presses?
- Is there the possibility of using an alternate method for achieving input normally done with a pointing device?

*Displays and monitors interfacing with software timed functions*

- Does the system avoid flashing or blinking text, objects, or other elements having a flash or blink frequency greater than 2 Hz and lower than 55 Hz?
- Can the user customize or eliminate timed responses?
- Does task-relevant warning or error information persist until user acceptance?
- Does the application enable user control of time-sensitive presentation of information?

**Table 42.4. Interfaces and Assistive Technology**

---

*Sounds and multimedia*

- Are there functions that offer the possibility of sending any text information to speech output?
- Does the speech output take place immediately after the event that generated it occurs?
- Can auditory warnings of alerts be provided in visual form?
- Is there the possibility of adjusting the sound frequency of audio warnings?
- Are there accessible alternatives to significant audio and video?
- Is there an option to adjust the sound volume?

*Data to display interface*

- Is textual information provided through operating system functions for displaying text?
  - Do the applications avoid overriding user-selected contrast and color selections and other individual display attributes?
  - Is there an option to display animation in a non-animated presentation mode?
  - Are there alternatives to the use of color as the sole source of information?
  - Are there color configuration schemas designed for people who have visual impairments?
  - Has every displayed text the possibility of having a cursor to navigate the text?
  - Is it possible to adjust the size and position of the icons and other objects displayed by the operating system?
  - Do all icons have an attached text label, and can the user choose to display the label only?
  - In forms, are component labels placed on the left and horizontally aligned with the first line of the corresponding component?
  - Does the system allow “always on top” windows?
  - Is it possible to adjust the size and position of the windows on the screen?
  - Are there options to minimize, maximize, and close windows?
  - Is it possible to switch working windows using the keyboard?
  - Does the application provide visual information through at least one mode to users with visual acuity between 20/70 and 20/200 without relying on audio?
  - If extensive ASCII art is used, does the application provide a link to allow a user to jump to the end of the ASCII art?
  - Does the application support settings for high contrast for all user interface controls and client area content?
  - Do the application windows inherit system settings for font, size, and color for all user interface controls?
  - Can the fonts be customized to obtain better legibility?
  - Is the scale and layout of objects adjusted when font size changes?
  - Does the application use an appropriate presentation of tables?
  - Does the application use user-determined color settings?
  - Does the system provide user control of multiple “always on top” windows?
  - Has the user choice of effect of input focus on window stacking order?
-

## 42.8 Improving the Organization of Work

- ❑ Optimize the organization of work processes with software to reduce complexities and improve service levels for specific job demands.
- ❑ Software should ease usability with user notifications that prompt organization-wide change such as passwords, server down or up times, integration, and access to systems in sequence.

## 42.9 Improving the LAN, WAN, and Web Environments of Work

- ❑ Optimize the work environment for both the mental and physical state of workers.
- ❑ Integrate accessibility and adaptability to site source deliverables. Ask:
  - Is the purpose of the site clear?
  - Does the site clearly address a particular audience?
  - Is the site useful and relevant to its audience?
  - Is the site interesting and engaging?
  - Does the site enable users to accomplish all the tasks they want or need to accomplish?
  - Can the users accomplish their tasks easily?
  - Does the information and the order in which it is presented suit the purpose?
  - Is the important information easy to find?
  - Is all information clear, easy to understand, and easy to read?
  - Do you always know where you are, or how to get where you want to go?
  - Is the presentation attractive?
  - Do the pages load quickly enough?

## 42.10 ISO Ergonomics Guidelines

- ❑ ISO IS 9241-20 Ergonomics of human system interaction—Accessibility guideline for information communication equipment and services—General guidelines
- ❑ ISO 9241-129 Ergonomics of human system interaction—Guidance on individualization
- ❑ ISO 9241-171 Guidance on accessibility (international standard version)
- ❑ ISO 9241-151 Software ergonomics for World Wide Web interfaces
- ❑ ISO 9241-210 Ergonomics of human system interaction—Human-centered design process for interactive systems
- ❑ ISO 9241-910 Framework for tactile and haptic interactions
- ❑ ISO 9241-920 Guidance on tactile and haptic interactions
- ❑ ISO/IEC TR 11581-1 Information technology—User interface icons—Introduction to and overview of icon standards

**Table 42.5. User notification**

---

Does the operating system use short and simple messages?
Is the display format of messages of the same type always the same?
Is user notification presented in relevant manner?

---

- ❑ ISO/IEC 11581-10 Information technology—User interface icons—Framework and general guidance
- ❑ ISO/IEC 4756 Framework for specifying a common access profile (CAP) of needs and capabilities of users, systems, and their environments
- ❑ ISO/IEC 25060 Common industry format for usability-related information—General framework
- ❑ ISO/IEC TR 29138-1 Information technology—Accessibility considerations for people with disabilities—Part 1: User needs summary
- ❑ ISO/IEC TR 29138-2 Information technology—Accessibility considerations for people with disabilities—Part 2: Standards inventory
- ❑ ISO/IEC TR 29138-3 Information technology—Accessibility considerations for people with disabilities—Part 3: Guidance on user needs mapping

## Human Factors to Be Considered Related to Job Competencies

### Knowledge

- Methods of work
- Materials
- Machines and equipment
- Instruments and tools
- Organization
- Environment

### Psychology

- Concentration
- Fatigue
- Emotions

### Biomechanical

- Balance, coordination
- Full range of motion
- Sitting
- Standing
- Head
- Upper extremities
- Lower extremities

### Safety

- OSHA
- ANSI
- CDC
- GHS
- EPA

### Strength and Stamina

- Lift, carry, place, transfer
- Materials, objects, people
- Weight
- Height, width, length

### Sensory

- Vision
- Hearing
- Olfactory
- Skin
- Taste
- Speech

### Quality

- ISO
- Six Sigma

The warehouse and storage areas are dynamic work areas and present important ergonomic considerations. Storage should not be a place for dumping potentially reusable items and retrieving them later. All storage activities need to be evaluated as potentially risky ones, where people are highly mobile, often operating forklifts, and dependent on critical tasks that require unobstructed vision of vertical planes. Assessment of storage spaces should include special considerations for storage from open storage using pallets stacked on the floor, automated high-risk bins, or cold storage where cold stress may occur. Hazardous material storage of gases, vapors, and dust requires specific and specialized methods.

Life safety load reviews in case of emergency are critical to these storage areas. Shipping and receiving are activities where staging and coordination are critical to material movement from the dock, on and off trucks, or from railroad cars. Mobile racking on rail systems, although automated, has inherent risks from falling products. Ergonomic assessment and intervention of storage facilities and practices is important to understanding the interactions between the worker, materials, and equipment in an often fast-paced environment with many outside vendors.

### 43.1 Ergonomic Design Benefits

- Improved safety
- Legal compliance

### 43.2 Consequences of Not Using Ergonomic Design

- Lost time
- Increased cost
- Injury, illness
- Disease
- Fatality

### 43.3 Accommodation

- Storage areas should allow for maximum maneuverability and safety. For example, passages must be wide enough to allow easy access to resources.
- Reach and stamina are also critical concerns. For example, if closets have shelves or clothing rods that are too high, a person in a wheelchair cannot retrieve or store things.
- Independent function is critical in order to maintain one's dignity and self-esteem.
  - The degree of access to stored items can either foster or impede self-reliance.
  - If storage areas are not accessible to all, additional staff must be made available to compensate for lack of reasonable accommodation.
- Storage areas should be accessible and uncluttered to allow independent access to supplies.

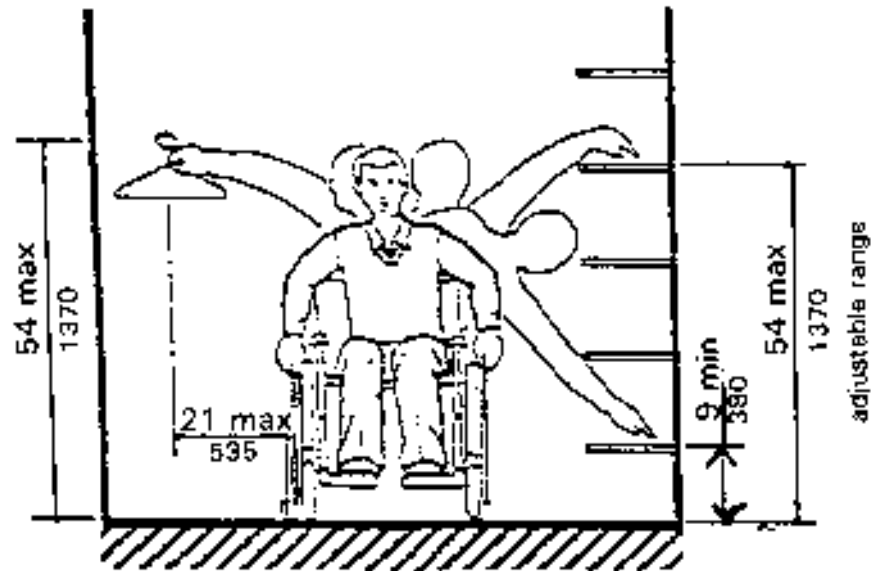

Figure 43.1. Storage should be within reach of all.

#### 43.4 Americans with Disabilities Act (ADA)—Storage—General

- ❑ It is required that all fixed storage facilities such as cabinets, shelves, closets, and drawers be accessible by ADA-AG 4.1.3 (12) and 4.1.7 (3e) and shall comply with 4.2.5.

##### 43.4.1 Clear Floor Space

- ❑ A clear floor space at least 30 inches by 48 inches (760 mm by 1220 mm) and complying with 4.2.4, which allows either a forward or parallel approach by a person using a wheelchair, shall be provided at all storage facilities.

##### 43.4.2 Height

- ❑ Accessible storage spaces shall be within at least one of the reach ranges specified in 4.2.5 and 4.2.6.
- ❑ Clothes rods shall be a maximum of 54 inches (1370 mm) from the floor.

##### 43.4.3 Hardware

- ❑ Hardware for accessible storage facilities shall comply with ADA-AG 4.2.7.4. Touch latches and U-shaped pulls are acceptable.

#### 43.5 Shelving

- ❑ The design of storage areas should include shelving that allows access from a height of 29 inches above the floor, and does not exceed a shelf depth of 12 inches.
- ❑ There should be areas for individual storage and units for project maintenance.

- Shelving should allow flexibility, whether for the employees maintaining supplies and inventory, or for customers who need access to products (e.g., a revolving display that allows a person access without movement).

#### 43.5.1 Shelving Guidelines

- Reach should not be overhead or with fully extended arms.
- The weight of stored items should not exceed five pounds.
- There should be minimal vibration from adjacent equipment.
- No sharp edges should contact the hand or wrist.
- No finger or pinch grasp should be necessary.
- The access to an item should take no more than two minutes.
- The removal of an item should take no more than 30 seconds.

## Human Factors to Be Considered Related to Job Competencies

### Knowledge

- Methods of work
- Materials
- Machines and equipment
- Instruments and tools
- Organization
- Environment

### Psychology

- Concentration
- Fatigue
- Emotions

### Biomechanical

- Balance, coordination
- Full range of motion
- Sitting
- Standing
- Head
- Upper extremities
- Lower extremities

### Safety

- OSHA
- ANSI
- CDC
- GHS
- EPA

### Strength and Stamina

- Lift, carry, place, transfer
- Materials, objects, people
- Weight
- Height, width, length

### Sensory

- Vision
- Hearing
- Olfactory
- Skin
- Taste
- Speech

### Quality

- ISO
- Six Sigma

The ergonomic importance of temperature control for employees working indoors is most often viewed as a comfort issue. However, as a condition of the work environment, temperature can significantly affect worker performance. As a rule of thumb, if the indoor temperature fluctuates up or down by more than 20 degrees from the best working temperature of 70 degrees, then ergonomic interventions for workers should be considered. It is important to develop a historical record of both existing and anticipated temperature conditions and worker reactions. With a record of actual temperature fluctuations and worker reactions, atmospheric controls can be developed to affect heating and cooling, air conditioning, circulation of air, humidity control, insulation, and shielding against radiation.

For persons who are exposed to extreme conditions, clothing and protective gear is useful to extend the tolerance of workers. For example, screening workers for heat and cold stress tolerance is acceptable as long as it is part of the essential functions of the job (e.g., heat stress at a die cast machine). Additionally, workers should be gradually acclimatized—schedule work and rest breaks, rotate shifts, and modify work to reduce energy expenditure. It is critical to educate workers that hydration is necessary in order to maintain metabolism in all work conditions. NOTE: Thirst is not an adequate indication of water requirements.

#### 44.1 Ergonomic Design Benefits

- Improved safety
- Legal compliance

#### 44.2 Consequences of Not Using Ergonomic Design

- Lost time
- Increased cost
- Injury, illness
- Disease
- Fatality

#### 44.3 Central Air System

- Provide adequate fresh air for percentage.
- Maintain humidification (30%–50%) with maintenance.
- Use plants as humidifiers and oxygen generators.

#### 44.4 Overhead Air Supply

- Use diffusers for occupancy/machine density.
- Regulate air speed and temperature controllers.
- Use directional controls to eliminate neck drafts.
- Lower partition height for fresh air distribution.

#### 44.5 Underfloor Air Supply

- Condition the air of individual workspaces.
- Provide easy access to temperature controls.
- Reposition diffusers as necessary.
- Provide the ability to tie in furniture.
- Use an equipment-ducted floor for HVAC and telecommunications centers.

#### 44.6 Individual Controls

- Allow for individual control of air speed and direction.
- Allow for individual control of air temperature.
- Have fresh air ducts near desks and individual workstations.
- Provide local air filtration (particulate and VOC).
- Provide local air monitoring devices.
- Install PC-based temperature sensors.
- Install radiant heat panels.

#### 44.7 Cooling Demand

- A major concern in the modern electronic office is the greatly increased cooling demand that accompanies the increase in the amount of operational equipment. This demand is mostly generated by specific activities at specific times of day.
- It is not only energy inefficient, but also thermally uncomfortable, to adjust over-all task-ambient air-conditioning setpoints to keep the hottest areas cool.

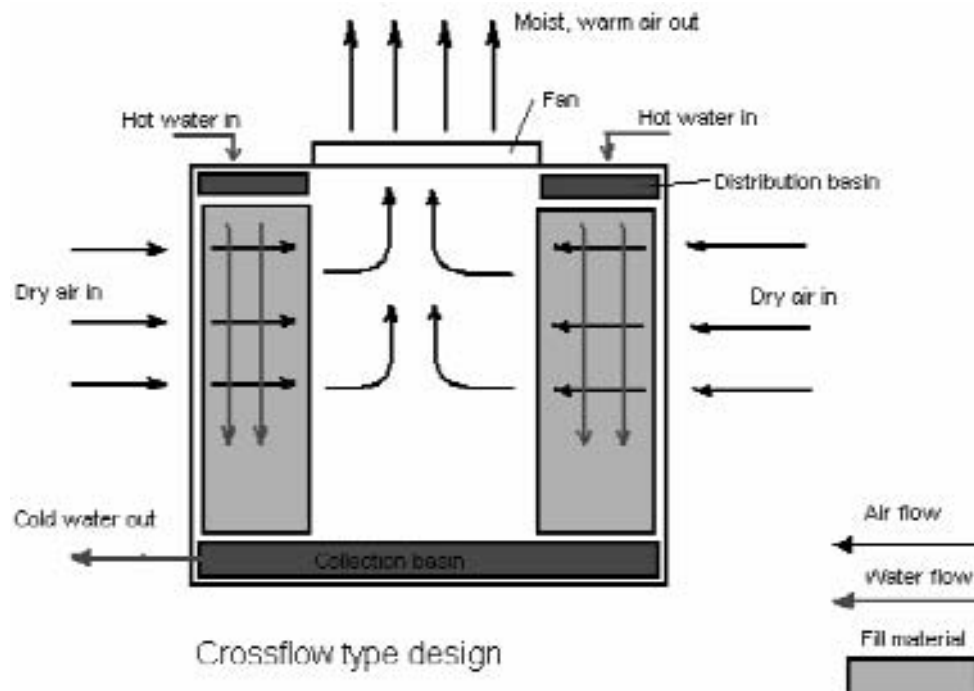

Figure 44.1. Temperature and airflow are critical to heating and cooling workspaces.

- Develop separate task and ambient cooling and ventilation systems, similar to the separation of task and ambient lighting. This requires establishing the differences between broadband ambient needs and time-and-activity-dependent task needs.
- The development of split task and ambient thermal air conditioning systems will require consideration of:
  - terminal mixing boxes
  - terminal reheat with closed-loop efficiency
  - individual/local conditioning units
  - multiple system cooling: air, water, radiant
  - diffuser controls: density, location, volume, direction
  - diffuser temperature mix (OA and RA)

#### 44.8 Heat Loss/Heat Gain Control

- A major function of the building enclosure is the control of heat loss and heat gain through the enclosure and its openings.
- The effective detailing of the wall and roof sections for high R values, minimized thermal bridging, minimized air filtration and exfiltration, and moisture control is of critical concern not only for thermal comfort but also for structural integrity and air quality.
- The integration of enclosure and structure is key to heat loss/heat gain control, including the joining of facade/floor and column/beam.
- The detailing of openings to minimize thermal bridging and filtration, as well as to maximize component R values, has led to a wide range of new heat loss/gain control strategies:
  - low E-glazings
  - triple glazing, high R-value with high solar transmission
  - new spacer technologies, gas-filled and vacuum air spaces
  - thermal breaks, low-infiltration framing and hardware
  - night insulation, air layers, foil layers
  - transparent insulation
  - wall and roof insulation, details to minimize thermal bridging, air filtration, moisture migration
  - enclosure and structure integration
  - waste heat and solar heat dumping in the facade

#### 44.9 Passive and Active Solar Heating

- Solar and other passive heating concepts are most applicable in buildings where heating is the predominant energy load, and there are often viable uses for solar heating in offices.
- Thermo-siphoning air panels or phase-change panels can offset perimeter loads.
- Solar energy through direct gain, indirect gain, or isolated gain can be used to meet the heating needs in greenhouse and atrium areas, which provide healthy spaces for plants and rest areas for office workers, with sunlight, increased oxygen, and vegetation.

- The availability of photovoltaic cells for solar power generation is a major opportunity for supporting tomorrow's power-hungry office; the replacement of electric lighting with innovative fiber optics is well within our energy future.

#### 44.10 Enclosure Integrity

- Besides meeting the thermal, visual, and air quality needs, the enclosure must also be designed for long-term durability.
- Enclosure integrity can be defined as the protection of the building's facade and contents from damage due to physical, chemical, or thermal forces or loads, including those due to moisture, temperature changes, air movement, radiation, biological incursion, and man-made or natural disasters.
- A number of factors affect the long-term integrity of facades:
  - module dimensions and assembly
  - finish material
  - compatibility of materials (phosphorescence, streaking)
  - continuity of the “rain screen”
  - critical separations between the continuous rainscreen, thermal barrier, and vapor barrier
- Be aware that the desire to solve each of these problems in a single line of defense has led to countless building facade failures.
- The introduction of new enclosure components and assemblies must take into account the following critical aspects, and also improve the long-term maintainability and durability of facades:
  - innovative waterproofing, detailing, drainage, and on-site water management
  - continuous vapor barrier techniques
  - thermal break materials; structure and enclosure connection
  - high-integrity expansion materials
  - rainscreen technologies, vented facades
  - built-in sensors, “tattletales” for mechanical and thermal properties
  - fire and smoke management components and assemblies
- Enclosure must enable water conservation and reuse.
- Effective water collection on the building and rerouting past the facade for gray water use in landscaping, will not only conserve fresh water resources (limited in many areas) but also will enhance the long-term durability of the enclosure.

## Human Factors to Be Considered Related to Job Competencies

### Knowledge

- Methods of work
- Materials
- Machines and equipment
- Instruments and tools
- Organization
- Environment

### Psychology

- Concentration
- Fatigue
- Emotions

### Biomechanical

- Balance, coordination
- Full range of motion
- Sitting
- Standing
- Head
- Upper extremities
- Lower extremities

### Safety

- OSHA
- ANSI
- CDC
- GHS
- EPA

### Strength and Stamina

- Lift, carry, place, transfer
- Materials, objects, people
- Weight
- Height, width, length

### Sensory

- Vision
- Hearing
- Olfactory
- Skin
- Taste
- Speech

### Quality

- ISO
- Six Sigma

The ergonomic importance of tools is to reduce the physical workload on the employee and to prevent occupational illness and injury. Tools need to be able to perform their function while being compatible with the anthropomorphic and biomechanical characteristics of workers. Tools and equipment should fit the individual user and be chosen for the specific demands of the task. Tools should be designed to maintain neutral body positions, which avoids twisting, vibration, static muscle loading, and pressure on tissues and joints. Factors that can be modified to prevent risks include tool size, weight, and balance; handle size and position; and power control design.

#### 45.1 Ergonomic Design Benefits

- Improved safety
- Legal compliance

#### 45.2 Consequences of Not Using Ergonomic Design

- Lost time
- Increased cost
- Injury, illness
- Disease
- Fatality

#### 45.3 Ergonomic Approach to Tools

- A successful ergonomics program must include many other facets besides the use of ergonomically designed tools. These include:
  - injury management
  - ergonomic analysis of existing and proposed jobs
  - training in ergonomics at all work levels
  - implementation of many engineering and administrative changes
- When a comprehensive ergonomics program is in place, the benefits will clearly justify the investment.
  - reduced incidence and severity of injuries
  - decreased medical and workers' compensation costs
  - reduced lost time
  - improved productivity
- The cost of acquiring ergonomically designed tools initially may be higher than for purchasing standard tools. The increased benefits far outweigh the extra costs.
- Tools that are ergonomically designed diminish the risk of cumulative trauma injuries such as carpal tunnel syndrome and tendinitis. As part of a complete ergonomics program, these tools save money in many ways, including:
  - medical costs for doctor visits, therapy, and surgery
  - workers' compensation costs
  - lost and restricted workdays
  - cost of retraining injured employees
  - cost of training new employees to take jobs of injured employees

- Additionally, jobs that cause cumulative trauma injuries often produce some of the following problems:
  - high absenteeism
  - high turnover
  - low employee morale
  - frequent rest breaks
  - high material waste
  - poor work quality and decreased production rates

#### **45.4 Biomechanics of the Hand and Wrist**

- In order to understand why these cumulative trauma disorders occur so frequently, and how to prevent them, it is necessary to first understand the biomechanics of the wrist and hand.
- Briefly, it is important to realize that strong, short muscles in the hand control the thumb. In contrast, tendons that pass through the hand and wrist into the forearm, where they attach to muscles, control the fingers. These tendons, some blood vessels, and the median nerve (which feeds the thumb, index finger, middle finger, and part of the ring finger) pass through the carpal tunnel in the wrist. This tunnel is an arch formed by small bones with a ligament stretched across them. Cumulative trauma injuries may occur when these tendons, blood vessels, and nerves become impinged upon by repetitive use or by awkward hand and wrist postures and movements.

#### **45.5 Cause of Cumulative Trauma Injuries**

- Tendinitis
  - more than 2,000 manipulations per hour
  - single or repetitive local strain
  - forceful and rapid repetitive movements
  - work with a deviated wrist, especially when combined with forceful exertions of the thumb
  - exertions with a flexed wrist
- Carpal tunnel syndrome
  - work with repetitive wrist flexion or extreme extension, especially in combination with a pinch grip
  - repeated force on the base of the palm or wrist

#### **45.6 Reducing Cumulative Trauma Injuries**

- The four major steps that should be taken to reduce the incidence and severity of cumulative trauma injuries are:
  - Use anthropometric data
  - Reduce the frequency of repetitions
  - Reduce the force required
  - Eliminate awkward postures

### 45.6.1 Anthropometrics

- ❑ Anthropometrics is the study of human body dimensions. It is important to consider the varying body dimensions of workers in order to select tools to fit their physical capabilities.
- ❑ Ergonomists aim to accommodate 90% of the population, those between the 5th and 95th percentiles.
- ❑ When designing and selecting tools, anthropometric data should be used to provide tools that are comfortable for all users and will not cause injuries.
- ❑ These data are useful when determining handle length, grip span, tool weight, and other pertinent factors.

### 45.6.2 Reducing the Frequency of Repetitions

- ❑ Tasks that require high repetition rates require more muscle effort and less recovery time, which can lead to fatigue and injury. Researchers are beginning to determine acceptable or safe limits for repetition.
- ❑ Reduce the number of repetitions as much as possible by:
  - broadening the variety of tasks each employee performs
  - rotating employees
  - encouraging employees to take mini-breaks and perform relief exercises
  - limiting overtime
  - increasing the number of employees assigned to a particular task

### 45.6.3 Reducing the Force Required

- ❑ If the force requirements are too high, the soft tissues may be strained, causing injury.
- ❑ Additionally, tendons, blood vessels, and nerves are impinged upon when the wrist is held in contact with hard or sharp-edged surfaces.
- ❑ Force on the hand should be reduced as much as possible by:
  - using power tools and assists whenever possible
  - using the stronger whole-hand grip instead of the weaker pinch grip
  - spreading the force over a wide area
  - providing adequate gripping surfaces that are not slippery, sharp, or excessively hard

### 45.6.4 Eliminating Awkward Postures

- ❑ Jobs should not require employees to work with awkward postures that impose biomechanical stresses on the joints and tissues, causing injuries.
- ❑ The following steps may be taken to eliminate awkward postures:
  - Keep wrist in a neutral position
  - Keep elbow close to the body and bent 90°–100°
  - Avoid reaching above shoulder height or behind the body
  - Minimize forearm rotation
- ❑ Work fixtures: Workers should not have to use their hands or bodies as a vise to hold objects; mechanical devices do this much better. Tooling fixtures and jigs should be set up to avoid awkward postures and excessive forces.

## 45.7 Selecting the Correct Tool

- ❑ As already indicated, improper tool selection or misuse of tools can cause cumulative trauma disorders. When selecting a tool, it is important to consider the tool design and what postures are required to do the task.

### 45.7.1 Acquiring Tools for Specific Functions

- ❑ Grip forces should be distributed over as wide an area as possible, and should not be concentrated on one or two fingers or in the center of the palm, which can lead to tendinitis or carpal tunnel syndrome.
- ❑ Choose tools with handles that span the hand and extend beyond the palm.
- ❑ Tools should not require employees to use the pinch grip. Maintaining the pinch grip, such as when holding tweezers or small components, forces the fingers to work four or five times harder than when gripping with the entire hand. The pinch grip combined with wrist deviation can lead to carpal tunnel syndrome.
- ❑ Select a tool that can be held with the entire hand.

### 45.7.2 Tool Size, Weight, and Balance

- ❑ Select tools just heavy enough to accomplish the task to minimize risks:
- ❑ Use counterweights or supports to minimize the weight of a tool; extra force should not be required to counteract the balancer.
- ❑ Select tools that can bend or are shaped to prevent awkward wrist or shoulder postures.
- ❑ Select balanced tools that can be held at the center of gravity.

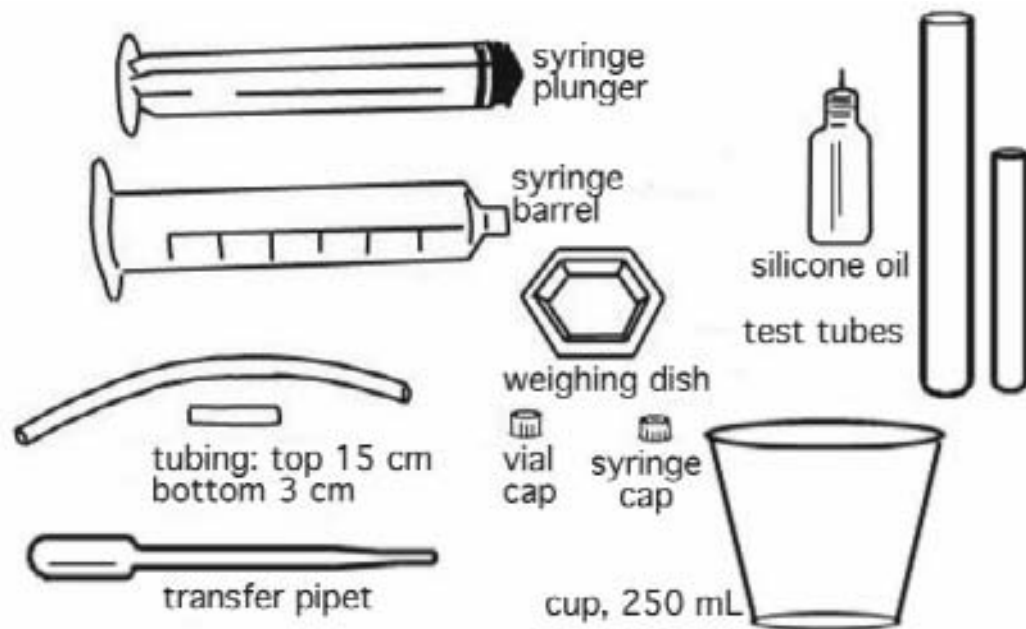

**Figure 45.1.** The better the fit to the hand, the better the tool.

- Handle size and position:
  - The tool handle should not exert forces on the sides of the fingers and the hand should not be exposed to sharp edges or corners. This is important since nerves and blood vessels are close to the skin and can be easily damaged.
  - Select tools with rounded edges at all areas of potential contact.
  - If the employee will be putting his or her fingers inside the handle, such as when using scissors or handsaws, be sure there is ample room for the fingers and hand.
  - If the user will be wearing gloves, be sure there is sufficient clearance for the glove thickness.
  - There should be no finger grooves in the handles of tools. These grooves do not accommodate a wide range of hand sizes and the fingers can rest on the edges of the grooves, increasing the risk of nerve or blood vessel damage.
  - A tool with knurled or textured gripping surfaces will be easier to hold and will reduce grip force requirements without causing injury.
  - Handles should be covered with smooth, no-slip, compressible material. This allows the hand to avoid exerting unnecessary force to hold a slippery tool in place. However, be sure the covering is not so soft that debris could become embedded.
  - Additionally, handles that are too soft diminish the feedback to the hand, which may result in excessive pressure being exerted to complete the task.
  - Choose a tool that can be used with both the right and left hands. It is not practical to have both right-handed and left-handed tools, because they are often held in the wrong hand or in the wrong configuration, which can lead to discomfort or injury.
  - Select tools that will allow the wrist to be held straight. Each job function may require different wrist positioning, which would necessitate the use of more than one tool for the job. Work performed with unnatural deviated wrist postures can lead to tendinitis or carpal tunnel syndrome.
  - Choose tools that will allow the elbows to be held close to the body. Working with raised elbows can cause muscle fatigue and pain.

### 45.7.3 Hand Tools

Choose wisely when selecting frequently used tools for the kitchen, housekeeping, laundry, and maintenance areas. Good ergonomics enhances tool safety, speeds process, and reduces waste. Handles should fit the grip size of the user. Use bent-handled tools to avoid bending wrists. Use appropriate tool weight. Select tools that have minimal vibration or vibration-damping devices. Implement a regular maintenance program for tools to keep blades sharp and edges and handles intact. Always wear the appropriate personal protective equipment.

- Specific guidelines for pliers and cutters
  - Handle length should be at least 4.0 inches.
  - Grip span should be 3.0–4.5 inches (open) and 2.0–2.5 inches (closed).
  - Select tools with spring returns.
  - Select tools with no finger grooves.
  - Handle curvature of no more than 0.5 inches over its entire length; handles should be almost straight with only slight curves.

- The high points of the curves should rest in the center of the palm and against the middle part of the fingers.
  - Each handle of the tool should be a mirror image of the other handle. This allows the tool to be comfortably and safely held in a variety of configurations.
  - Tools should not have right- and left-handed models.
  - A tool should only be used for the job for which it was designed. Using it for other jobs may increase the risk of injury.
  - Select only high-quality tools that will do the job for extended periods of time in the best manner possible. This will allow employees to perform their jobs more safely and efficiently and reduce the chance of tools breaking. Cutters and saws should have the highest quality blades that will maintain their sharpness, and not require an increase of force over time, as does a tool whose blade becomes dull.
- Specific guidelines for power tools
- Power control: Workers should be able to turn a tool off and on or keep it running without using extra force. Auto-start/stop tools are preferred. Steps to reduce hazards include minimizing rotational forces with variable torque settings and avoiding high-tension and one-finger triggers.
  - Handle breadth should be 2.0–3.0 inches for pistol-grip tools.
  - Handle diameter should be 2.0–2.5 inches for cylindrical tools.
  - Handle length should be at least 4.0 inches.
  - Finger-stop flange should be at the base of pistol-grip tools.
  - There should be no finger grooves on the tool.
  - Handle should be located near tool's center of gravity.
  - Use an overhead balancer with heavy tools (>1.0 lb.).
  - Push-to-start activation should be used whenever possible.
  - Thumb triggers and strip triggers are preferred over single button triggers.
  - Minimize exposure to the vibration of power tools by selecting a tool with compressible rubber handles.
  - If necessary, provide padded gloves, interject rest periods, or follow a job rotation schedule.
  - Select tools with torque-control settings whenever applicable.
  - All power and air cords should be very flexible and not interfere with the operation and handling of the tool.
- Specific guidelines for manual screwdrivers
- Handles should be at least 5.0 inches long.
  - Handle diameter of medium- and large-blade screwdrivers that are used to exert force should be in the range of 1.0–1.35 inches, indicating a recommended circumference of 3.1–4.2 inches.
  - Handle diameter of small, thin-blade screwdrivers that are used for precision operations should be in the range of 0.7–0.8 inches, translating into a circumference of 2.2–2.5 inches.
  - There should be a flange on the base of the handle. This will reduce the risk of slippage and decrease the grip-force requirements.
  - Choose a tool that does not have fluted handles, finger grooves, or large indentations on the handles. These should be avoided because they can cause discomfort and nerve and blood vessel damage.

#### 45.7.4 The Final Selection Process

- ❑ When selecting new ergonomically designed tools, it is important to choose one to three possible tools and evaluate each one very carefully.  
—The evaluation should include a visual check to determine which ergonomic criteria are met.
- ❑ Most important, the tools should be used and evaluated by a representative group of employees for an extended period of time (at least two weeks).
- ❑ Each employee who uses the tools should complete a written survey to provide information on worker comfort and tool performance levels. Once all the data have been collected and analyzed, new tools can be selected.

#### 45.8 Training

- ❑ After ergonomically designed tools are purchased, all employees who will use them should receive proper training.
- ❑ Training should include an introduction to ergonomic principles as well as specific instructions on how to correctly use the tools. It is often difficult for employees to get used to a new tool or method, but it's even more difficult if nothing is explained or demonstrated.
- ❑ All the benefits of purchasing new ergonomically designed tools can be destroyed if they are not properly introduced into the workplace.

#### 45.9 Tool Maintenance

- ❑ An organized and thorough tool maintenance program is essential. The ergonomic benefits of a tool can be negated if it is not working properly.
- ❑ All cutting blades should be sharpened when they begin to dull. Using a dull blade requires the employee to exert more force to complete a task than when using a sharp blade.
- ❑ Torque levels should be checked regularly to ensure that they are appropriate. Using a tool with the wrong torque can make it difficult to complete the task and can cause the tool to twist in the hand, forcing the wrist to overextend quickly.
- ❑ In addition, springs on two-handled tools such as pliers and cutters must be working well. Tools without properly working springs require employees to open the tool with their inlays after each use.
- ❑ Tools with defects such as worn handles and broken parts should be replaced immediately.

#### 45.10 ANSI B11 Technical Report

- ❑ The Machine Tool Safety Standards Committee (B11) of the American National Standards Institute took the initiative in the early 1990s to compose a voluntary standard involving the design, installation, and use of tools/machines from an ergonomics perspective to reduce workplace injury and improve product production (ANSI Technical Report: Ergonomic Guidelines for the Design, Installation and Use of Machine Tools).

## Human Factors to Be Considered Related to Job Competencies

### Knowledge

- Methods of work
- Materials
- Machines and equipment
- Instruments and tools
- Organization
- Environment

### Psychology

- Concentration
- Fatigue
- Emotions

### Biomechanical

- Balance, coordination
- Full range of motion
- Sitting
- Standing
- Head
- Upper extremities
- Lower extremities

### Safety

- OSHA
- ANSI
- CDC
- GHS
- EPA

### Strength and Stamina

- Lift, carry, place, transfer
- Materials, objects, people
- Weight
- Height, width, length

### Sensory

- Vision
- Hearing
- Olfactory
- Skin
- Taste
- Speech

### Quality

- ISO
- Six Sigma

The importance of ergonomic training is to create work practice controls. Ergonomics reduces the risk of force, awkward posture, repetition, and duration by implementing work practices controls. These are procedures for safe actions of job tasks that reduce the duration, frequency, or severity of exposure (temperature and vibration stress) to a hazard. When workers are trained in ergonomics, one of the first positive outcomes is that standard operating procedures change. One of the most frequent changes is that workers are more efficient with on-time completed job tasks with quality. This is what a strong organization with a strong ergonomics program accomplishes.

Training changes the standard way of doing business. Training that is based on valid competency-based job descriptions (knowledge, psychology, biomechanics, sensory, strength and stamina, safety, and quality) matched with the findings of job safety analysis do best to integrate productivity, safety, and quality. Training is continuously improved because it is job-title and worker specific. It includes the workers' ideas. Ergonomic training results in improved engineering controls, accommodation, and supervision. Workers who are trained in ergonomics begin to report new ideas. They usually have the best ideas since they have firsthand experience with the tasks and how to modify them. This results in work practice controls that can be understood and accepted by managers and supervisors.

#### 46.1 Why Train?

Training and educating members of the organization on work-related musculoskeletal disorders is critical to the success of an ergonomics program. Training and education should give both supervisors and workers an understanding of the potential risk of injuries, their causes, symptoms, prevention, and treatment. The more aware workers are of the musculoskeletal hazards in their workplace, the more likely they are to work toward reducing injuries.

#### 46.2 What to Train On: Ergonomic Work Methods

First, employees should be taught about their own body's strength and stamina, then integrated with their own biomechanical and sensory acuities, how to perform their jobs with the lowest physical, sensory, and stamina stress. This includes the best posture; how to limit force; take appropriate rest breaks; and avoid excesses of heat, cold, and vibration. Simulations should be done with best posture role modeling of how to handle materials, tools, instruments, machines, materials, and equipment safely. Considerations for organizational demands of overtime and fatigue as well as environments are important training concepts.

Second and equally important is that training in all required content areas must include the ergonomic aspects of the safety expectation. For example, ladder safety training should role-model ergonomics to teach how to carry a ladder to reduce strain. Housekeeping training should include how to lift, carry, and transfer bottles of chemical used in cleaning. Lifting training should include the assessment of the object's or person's stability.

Goals to aim for include:

- Ergonomics training tailored to the workplace environment and client needs
- Ergonomics training for entire departments, units, or individuals as needed
- Training supervisors and employees in the workplace ergonomics program and their role in it
- Tools for the recognition of MSD signs and symptoms
- Emphasizing the importance of early reporting and the consequences of failing to report them early
- Tools for the identification of MSD hazards in the workplace
- Overview of the methods used to control MSD

#### 46.2.1 Gradual Introduction to Work

New and returning employees in jobs involving risks, such as prolonged repetitive motion, should be introduced or retrained on safety practices and gradually returned to a full workload. This will support work capacity improvement and prevent injury.

Ergonomics training provided can be either for general awareness or specific to the particular job or task. Job safety analysis and departmental needs analyses determine what type of ergonomics training is provided based on:

- The nature of the task performed
- The type of tools, equipment, or processes involved
- The length of time the task is to be performed

#### 46.2.2 General

General training involves providing instructions to supervisors and employees about the hazards involved with their jobs and includes:

- Types of musculoskeletal disorders often associated with the job
- Risk factors that may contribute to or cause these disorders
- How to prevent these disorders from occurring
- Recognition and reporting of symptoms associated with these disorders

#### 46.2.3 Job-Specific

Job-specific training involves the following:

- Hands-on training before beginning a regular computer or production job
- Care and proper use of all tools, instruments, machines, and equipment
- Proper lifting techniques and devices with various materials
- The neutral-posture way to stand, sit, bend, turn, reach, grasp, push/pull, and climb
- Identification of hazards in the area, such as slippery surfaces, sharp edges, moving machinery, or vehicles
- Use of proper personal protective equipment, if any

## 46.3 Whom to Train

Training should involve all employees, including support personnel. These people should all receive training on musculoskeletal risk factors:

- Supervisors and employees
- Engineers
- Maintenance personnel
- Purchasing personnel
- Safety and risk control managers
- Health care providers
- Insurance administrators

### 46.3.1 Supervisors

It is important for supervisors to get training similar to that of their employees, as they are responsible for ensuring that their employees use work practices that are ergonomically correct and safe. Supervisors should receive additional training that will allow them to:

- Recognize early signs and symptoms of work-related musculoskeletal disorders and inform health care providers about them
- Recognize and correct hazardous work practices
- Understand and emphasize the importance of the ergonomics program

### 46.3.2. Engineers, Architects, and Maintenance Staff

Training for engineers and maintenance personnel should include how to correct musculoskeletal hazards through job and workstation design and maintenance. These personnel should be able to recognize hazards and modify workstations to eliminate or reduce hazards.

### 46.3.3 Purchasing Personnel

Purchasing personnel should be trained to understand basic ergonomic concepts of tool, equipment, and furniture design. This will help them make more informed choices in their purchasing decisions.

## 46.4 Responsibilities of Trained Individuals

### 46.4.1 Employees

Employees should attend all necessary workplace ergonomics training and apply the material learned in their workplaces and work practices. Employees should adopt the provided work practice controls to reduce identified ergonomic risks.

#### 46.4.2 Supervisors

Supervisors should provide time to attend all necessary training and promote a climate that encourages and reinforces new equipment usage and methods.

Supervisors should provide the resources to institute the controls to reduce identified ergonomics risks.

#### 46.4.3 Organization

The basis of training is to maintain continuous improvement to organizational demands. Based on reviews of job safety analyses and interventions, risk managers and trainers should provide feedback on the recommended controls to reduce identified ergonomics risks to supervisors and employees including:

- Explaining job stresses determination (methods, appropriate tools, etc.)
- Developing continuous solution options
- Facilitating training meetings between employee and supervisors
- Work for continuous improvement by providing follow-up after controls are implemented

### 46.5 Questions Organizations Must Answer

*When is ergonomics training offered?*

- Ergonomics training is offered and scheduled based on client needs. Training can be provided on-site.

*How is training requested?*

- Whom do employees contact to schedule a needs assessment and training?
- Who should be trained by prioritization of risk?

## Human Factors to Be Considered Related to Job Competencies

### Knowledge

- Methods of work
- Materials
- Machines and equipment
- Instruments and tools
- Organization
- Environment

### Psychology

- Concentration
- Fatigue
- Emotions

### Biomechanical

- Balance, coordination
- Full range of motion
- Sitting
- Standing
- Head
- Upper extremities
- Lower extremities

### Safety

- OSHA
- ANSI
- CDC
- GHS
- EPA

### Strength and Stamina

- Lift, carry, place, transfer
- Materials, objects, people
- Weight
- Height, width, length

### Sensory

- Vision
- Hearing
- Olfactory
- Skin
- Taste
- Speech

### Quality

- ISO
- Six Sigma

The importance of ergonomics to transportation is the safety of individual, product, and physical areas (roads, grounds, and facilities). The role of ergonomics is to provide an understanding of the human factors of how people perform as drivers, using a system of components in the safe operation of vehicles (cars, trucks, golf carts, forklifts, etc.). Ergonomics studies driver performance from the perspective of intellectual demands of safety rules in changing environments. Ergonomics further considers psychological and vehicle (rail cars, bicycles, scooters) design factors, which include the competent integration of biomechanical, sensory, strength, and stamina factors.

The focus of ergonomics is to improve driver performance based on vehicle design and recognition of unsafe conditions, and to reduce unsafe behaviors. Drivers' competence in today's technologically sophisticated vehicles begins with the benefits from existing technologies (e.g., anti-lock brakes, backup lights and alarms, and talking Global Positioning Systems) plus new in-vehicle technologies (e.g., too-close alarms). Ergonomics knowledge about driver behaviors and performance reduces risk by matching optimum driver competencies to screening protocols specific to each vehicle's technologies.

#### 47.1 Ergonomic Design Benefits

- Improved productivity
- Improved safety
- Improved quality
- Legal compliance

#### 47.2 Consequences of Not Using Ergonomic Design

- Lost time of workers
- Increased cost of training or rework
- Legal citation
- Injury, illness
- Disease
- Fatality
- Lost quality

#### 47.3 Driver Competencies and Ergonomic Risks

The indicators of an increased driver safety risk fall into seven competencies. These competencies are directly related to screening variables that can be tested. Screening can be done by a combination of interviewing, observing, testing, and driver simulation for:

- Knowledge: The worker gets disoriented, rerouted, or lost frequently on new assignments. Cannot rethink reaction to unexpected situations. Drives at inappropriate speeds to make up for or not acknowledging time constraints.
- Psychology: Worker expresses feeling uncomfortable, nervous, or fearful of driving under certain conditions. Worker is distracted and displays limitation of focus to plant signals (yellow-lined driving lanes, back-up alarms, change in floor levels)



**Figure 47.1. Transport: Find the “near miss.” Fatigue!**

- Biomechanical: Worker displays slowed reaction time in environments. Has difficulty staying in traffic lanes (on the dock or highway lanes). Medications compromise function (prescribed and over the counter). Increase in slips, trips, and falls.
- Sensory: Limitation of acuity to signals, road signs, and pavement markings. Difficulty in spatial judgment of vehicle placement. Change in peripheral vision.
- Safety: Increase of near misses. Lack of acknowledgment of safety violations. Use of mind- or body-altering substances.
- Quality: Dents or scrapes on the vehicle. Traffic tickets and legal citations. Reports from coworkers.

#### **47.4 Ergonomic Driver Screening Protocol for Transport Vehicles**

- Knowledge: Simulation tests of reaction time and response to street signs, yields of right of way, and traffic lights.
- Failure to maintain the vehicle within safety protocol.
- Medication review.
- Psychological: Stress tests of random driving situations and tolerance without frustration and anger occurring.
- Biomechanical: Test of full range of motion, particularly in the neck.
- Tests of muscle control and flexibility, particularly in the neck.
- Tests of recognition of safe driving response and reaction time.
- Sensory: Integration of biomechanical coordination with senses to respond to other workers, pedestrians, bicyclists, and other drivers.
- Vision: Near-sighted, far-sighted, and illumination needs for reading signs and on road safety.

- Difficulty with glare from oncoming headlights, streetlights, or bright shiny objects, especially at dusk or dawn.
- Hearing: Ability to attend and distinguish sounds of the road and alarm signals.
- Sensation: Grip strength and stamina.
- Safety: Simulated response to near miss situations.
- Quality: Demonstration of actions using the vehicle at top performance to meet productivity standards.
- Load shelf using forklift.

### **47.5 Ergonomic Driving Interventions**

- Knowledge: defensive driving courses and medication use
- Psychological: training on road rage and sleep deprivation
- Biomechanical: weight training and diet
- Sensory: supports to adapt such as new glasses, hearing aids, large rear view mirror and side mirrors
- Safety: engineering controls to increase alert time, such as yellow poles in front of shelves near forklift areas
- Quality: retraining to the standard of performance

## Human Factors to Be Considered Related to Job Competencies

### Knowledge

- Methods of work
- Materials
- Machines and equipment
- Instruments and tools
- Organization
- Environment

### Psychology

- Concentration
- Fatigue
- Emotions

### Biomechanical

- Balance, coordination
- Full range of motion
- Sitting
- Standing
- Head
- Upper extremities
- Lower extremities

### Safety

- OSHA
- ANSI
- CDC
- GHS
- EPA

### Strength and Stamina

- Lift, carry, place, transfer
- Materials, objects, people
- Weight
- Height, width, length

### Sensory

- Vision
- Hearing
- Olfactory
- Skin
- Taste
- Speech

### Quality

- ISO
- Six Sigma

The importance of ergonomics when working with vendors is to determine their products' conformance to relevant human factors needs. The goal is to reduce the risk of occupational illness and injury. Job safety analysis provides data on job demands. These data can be used to specify products that reduce the probability of injury—for example, jackhammer vibration that could be dampened with anti-vibration gloves. Purchasing and risk management should work together to improve the integration of productivity, safety, and quality. The range of products ergonomically specified will cross all departments to include new equipment, software and hardware, personal protective equipment, and office furnishings (especially chairs). Purchases made for an organization must be considered part of the engineering controls of risk management.

Maximum ergonomic value is realized when negotiation of bid proposals includes a worker evaluation period. Testing of products by workers should include job safety analysis of force, awkward posture, repetition, duration, and temperature and vibration stress. The context of testing is in the methods of work, with the materials used and integrated with machines and equipment, instruments and tools in indoor and outdoor environments. The ergonomic evaluation process increases workers' product acceptance by testing product usability and durability. When organizations and vendors work together to utilize employee experience and ergonomics, staff responds with productivity, safety, and quality.

#### **48.1 Ergonomic Design Benefits**

- Improved productivity
- Improved safety
- Improved quality
- Legal compliance

#### **48.2 Consequences of Not Using Ergonomic Design**

- Lost time
- Legal citation
- Injury, illness
- Disease
- Fatality
- Lost quality

#### **48.3 Improving the Match of Worker Capabilities to Methods of Work**

- Define the job by competencies for knowledge, psychology, biomechanics, sensory, strength and stamina, safety, and quality.
- Validate job demands by intensity of the requirement (common sense to expert).
- Conduct job safety analysis.
- Validate job demands by frequency and severity of risk.
- Prescreen.
- Use industry-specific testing, job task simulation.
- Prescreen workers at each stage of employment.

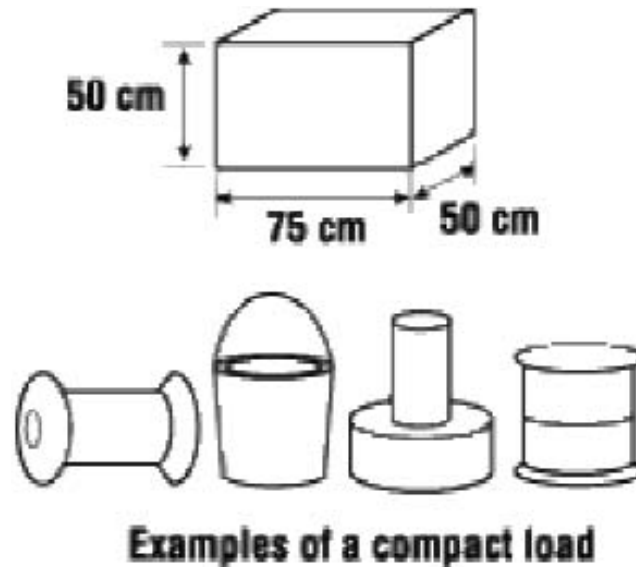

**Figure 48.1. Changing load size to fit workers and just-in-time work makes for the best vendor relations.**

- First hired, lateral moves, promotion, return to work.
- Screen by age, injury, disease, and disability as it relates to validated job demands.
- Job safety analysis factors may dictate screening for human factors consequences, PPE, and competence to take safe actions.
- Biomechanical: Multifunctional use of the body in static and dynamic postures and positions.
- Sensory: Multitask coordination of senses.
- Hearing: Cross-cultural languages.
- Vision: Cross-cultural labeling (MSDS).

#### **48.4 Improving the Methods of Work**

- Integrate the knowledge, psychological, safety, and quality competencies of business requirements with the physical and sensory demands.
- Physical: Coordinate and cross-train workers on the integrated fit to multitask demands of ergonomics across vendors and products.
- Create safe action protocols for high strength and stamina tasks and seek vendors who can respond to specifications.
- Sensory: Set up work protocols to increase eye-hand and all sensory coordination (sight, hearing, touch, smell, taste).

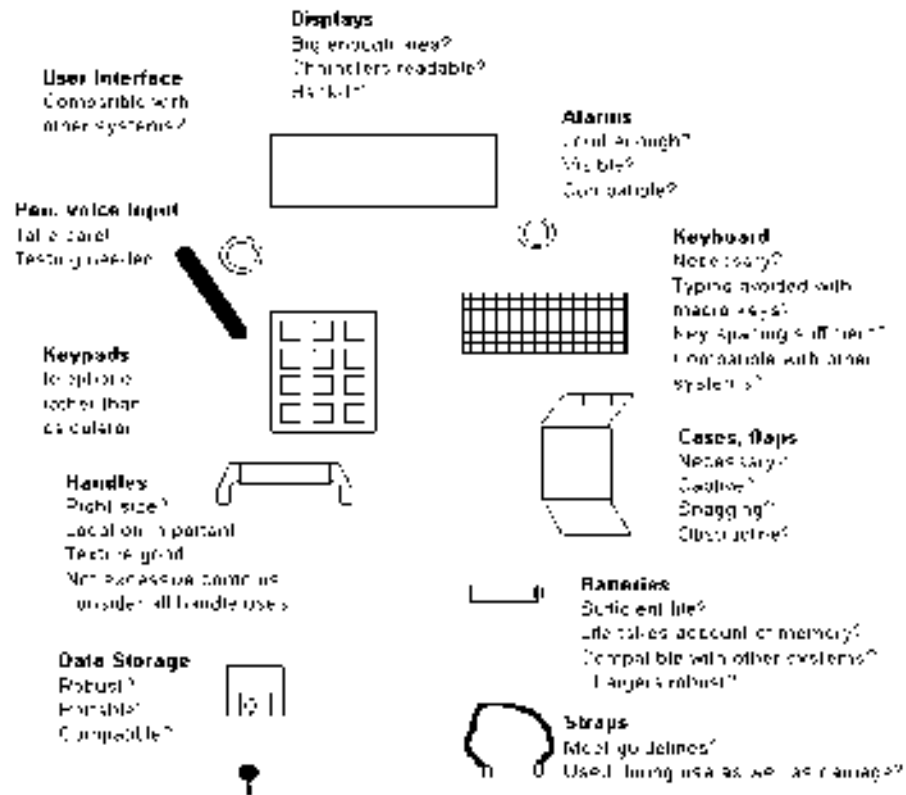

Figure 48.2. Work materials analysis.

#### 48.5 Improving the Materials of Work

- Develop a clear understanding of all the ergonomic cost components and lost profit opportunities if vended products create occupational risks.
- Integrate the knowledge competencies of safe actions when assessing products across departments.

#### 48.6 Improving the Equipment and Machines of Work

- Control the hazards to reduce risk.
- Reduce human factors risks by analyzing vendor solutions by:
  - elimination
  - accommodation
  - mechanization
  - automation
  - robots
- Create solutions that increase safe integration of humans and vended products that includes preventive maintenance.

#### 48.7 Improving the Instruments and Tools of Work

- Increase the use of ergonomic tools.

### 48.8 Improving the Organization of Work

- ❑ Optimize work processes with on-demand vendor support to improve service levels for specific products/vendor product lines
- ❑ Structure ergonomics and accessibility guidelines based on ADA, Building Regulations, industry best practice and OSHA standards.
- ❑ Rely on job safety analysts and experienced ADA assessors, familiar with a range of job demands and disabilities to
  - access problems and solve them with vendors (use Jobs Accommodation Network to find products [www.jan.wvu.edu](http://www.jan.wvu.edu))
  - identify the most practical and cost-effective ways of meeting both your legal obligations and your business needs with the qualified vendors
- ❑ Expect vendors to give clear and straightforward recommendations for ergonomic and accommodated solutions.

### 48.9 Improving the Environment of Work

- ❑ Optimize the work environment for both the mental and physical state of workers.
- ❑ Integrate accessibility, adaptability, density, design of space, housekeeping, lighting, passages, temperature, and training into a strategy that builds vendor competencies at ergonomic guidelines.

## Human Factors to Be Considered Related to Job Competencies

### Knowledge

- Methods of work
- Materials
- Machines and equipment
- Instruments and tools
- Organization
- Environment

### Psychology

- Concentration
- Fatigue
- Emotions

### Biomechanical

- Balance, coordination
- Full range of motion
- Sitting
- Standing
- Head
- Upper extremities
- Lower extremities

### Safety

- OSHA
- ANSI
- CDC
- GHS
- EPA

### Strength and Stamina

- Lift, carry, place, transfer
- Materials, objects, people
- Weight
- Height, width, length

### Sensory

- Vision
- Hearing
- Olfactory
- Skin
- Taste
- Speech

### Quality

- ISO
- Six Sigma

**W**aste management is the collection, transport, processing (waste treatment), recycling, or disposal of waste materials, usually ones produced by human activity, in an effort to reduce their effect on human health or local aesthetics or amenity. A subfocus in recent decades has been to reduce waste materials' effect on the natural world and the environment and to recover resources from them. The importance of ergonomics to waste management is that it involves three distinct safe action protocols. They are waste evaluation (toxicity), waste cleanup, and waste material handling for disposal.

The ergonomics of waste management is an ongoing safety and facility issue that in addition can have safety consequences due to its unstable or large dimensions, infectious nature, or mix of debris in post-disaster cleanup. Waste management can range from normal housekeeping challenges (scrap materials) to being highly regulated due to biohazards (animal parts) or part of disaster management (chemical toxins). All three situations can require engineering interventions for awkward postures, force, repetition, duration, or temperature.

Waste management also creates psychological stress for workers who may fear infection. In all waste management protocols, the goal is safe cleanup processes that are done in a healthful manner. Waste management and waste removal often include broken glass, debris, or other materials with cutting edges. Setting protocols for safe management, gathering, and disposal is key. Ergonomic factors are part of the beginning, middle, and end of all major cleanup operations to ensure safety and proper disposal. Ergonomics fit, selection, and use of personal protective equipment (eye-wear, gloves, and dust masks/respirators) for waste management operations are designed to support the most efficient and safe working conditions through all cycles.

#### **49.1 Ergonomic Design Benefits**

- Improved productivity
- Improved safety
- Improved quality
- Legal compliance

#### **49.2 Consequences of Not Using Ergonomic Design**

- Lost time
- Legal citation
- Injury, illness
- Disease
- Fatality
- Lost quality

#### **49.3 Improving the Match of Worker Capabilities to Methods of Work**

- Define the job by competencies for knowledge, psychology, biomechanics, sensory, strength and stamina, safety, and quality.
- Validate job demands by intensity of the requirement (common sense to expert).
- Conduct job safety analysis.

- Validate job demands by frequency and severity of risk.
- Prescreen.
- Very Important: Persons who are at increased risk of acquiring infection or for whom infection has serious consequences, as in immune compromised or suppressed, may not be appropriate for waste management positions.*
- Vaccination status may be required for some job demands.
- Industry-specific testing, job task simulation.
- Screen for essential functions by age, disease, disability, and injury.
- First hired, lateral moves, promotion, return to work.
- Job safety analysis factors may dictate screening for human factors consequences, PPE, and competence to take safe actions
- Biomechanical:
  - grip with gloves and force required to manipulate objects
  - lift, throw, place, or carry waste in varying containers
  - range of motion in full body suits that does not impede reflexes
  - lower body constraints with knee pads for walking vs. kneeling tasks
  - foot flexibility with friction coefficient (amount of friction or grip between floors and shoes)
- Sensory:
  - hearing: acuity to distinguish normal speech or with hearing protection
  - vision: acuity to distinguish objects with darkened shields or tinted glasses
  - smell: acuity to determine toxics smells above permissible limits
  - sensation: acuity to distinguish grip strength contact through gloves

#### 49.4 Improving the Methods of Work

- Integrate the knowledge, psychological, safety, and quality competencies with the waste management demands of biomechanics and sensory.
- Physical: Coordinate and cross-train workers on the integrated fit for all PPE for specific waste management job competencies.
- Waste management of materials requires handling, moving, lifting, and carrying of materials with and without the use of mechanical equipment.
- Minimizing injuries from materials handling requires
  - inspecting materials for slivers, jagged edges, burrs, rough or slippery surfaces
  - getting a firm grip on the object
  - keeping fingers away from pinch points, especially when setting down materials
  - keeping hands away from ends of lumber, pipe, or other long objects, to prevent them from being pinched
  - wiping off greasy, wet, slippery, or dirty objects before trying to handle them
  - keeping hands free from oil and grease
- In most cases, PPE gloves, hand leathers, or other hand protectors must be used to prevent hand injuries.
- If a load is thought to be more than one person can handle, two employees should be assigned to the waste management operation, or materials handling equipment should be provided.
- Sensory: Set up work protocols to increase eye-hand and all sensory coordination (sight, hearing, touch, smell, taste).



**Figure 49.1.** Proper containers allow for the correct management. This looks like a spill ready to happen.

#### **49.5 Improving the Materials of Work**

- Purchase material handling plastic bags with lowered risk for breakage or seepage.
- Integrate the knowledge competencies of safe actions when using materials that are bagged and contained.
- Contain materials that may be biohazards in, for example, syringes that re-sheathe the needle, needleless systems, and other safety devices when appropriate.

#### **49.6 Improving the Equipment and Machines of Work**

- Purchase material handling equipment with lowered risk for breakage or seepage.
- Use hard-walled containers for non-disposable sharps, which must be placed in a hard-walled container for transport to a processing area for decontamination, preferably by autoclaving.

- Waste management/safety equipment must be properly maintained and annually certified for laboratory work, such as biological safety cabinets, preferably Class II.
- Physical containment devices are used whenever procedures with a potential for creating infectious aerosols or splashes are conducted. These may include centrifuging, grinding, blending, vigorous shaking or mixing, sonic disruption, and opening containers of infectious materials whose internal pressures may be different from ambient pressures.
- Contaminated equipment must be decontaminated before it is sent for repair or maintenance or before removal from the laboratory.

#### 49.7 Improving the Instruments and Tools of Work

- Purchase ergonomic instruments and tools for job tasks that work well with PPE requirements.
- Syringes that re-sheath the needle, needle-free systems, and other safety devices are used when appropriate.
- Broken glassware must not be handled directly by hand, but must be removed by mechanical means such as a brush and dustpan, tongs, or forceps.

#### 49.8 Improving the Organization of Work

- Purchase material handling plastic bags with lowered risk for breakage or seepage.
- Optimize work processes to eliminate the need for PPE.
- Integrate safety waste management stations into the right work areas.
- Integrate safety stations by waste management standards such as biosafety hazards.
- Ensure that all laboratory and support personnel receive appropriate training for the potential hazards associated with the work involved, necessary precautions to prevent exposures, and exposure evaluation procedures.
- Ensure that biosafety procedures are incorporated into standard operating procedures for the laboratory.
- Ensure that personal protective equipment and necessary safety equipment is provided and used.
- Ensure compliance by laboratory personnel with the relevant regulations, guidelines, and policies.
- Safety glasses with eyewash stations.
- Hearing protection with noise meters.
- Train and cross-train.
- First response.
- First aid.
- Emergency evacuation.

#### 49.9 Improving the Environment of Work

- Optimize work environment for both the mental and physical state of workers by keeping waste management strategies at optimum.
- Signage is key to work area identifiers and PPE requirements.

- ❑ In laboratories maintain all regulatory standards.
- ❑ Access should be restricted with locked doors.
- ❑ Monitor humidity and oxygen.
- ❑ Less humidity means fewer allergens and pollutants in high-volume waste environments; workers breathe more easily.
- ❑ Less oxygen in the air, people breathe more deeply, expelling more carbon dioxide and allowing more oxygen into the brain.
- ❑ Integrate accessibility, adaptability, density, design of space, housekeeping, lighting, passages, temperature, and training into safety components of waste management procedures.

## Human Factors to Be Considered Related to Job Competencies

### Knowledge

- Methods of work
- Materials
- Machines and equipment
- Instruments and tools
- Organization
- Environment

### Psychology

- Concentration
- Fatigue
- Emotions

### Biomechanical

- Balance, coordination
- Full range of motion
- Sitting
- Standing
- Head
- Upper extremities
- Lower extremities

### Safety

- OSHA
- ANSI
- CDC
- GHS
- EPA

### Strength and Stamina

- Lift, carry, place, transfer
- Materials, objects, people
- Weight
- Height, width, length

### Sensory

- Vision
- Hearing
- Olfactory
- Skin
- Taste
- Speech

### Quality

- ISO
- Six Sigma

The importance of windows to ergonomics is to consider that windows still represent a symbol of higher status and freedom between the “haves” and the “have-nots,” and therefore windows present a psychological feeling of control. The dominant opinion among workers in windowless environments is that they are being deprived of both natural light and “real” air. This deprivation, then, appears to be a psychological one. Workers often add, “I am trapped in here.” This is particularly true in climates where weather keeps people indoors for many weeks. The real data vary from industry to industry as to whether or not windowed environments increase productivity and quality. It appears that more workers than not desire windows as a psychological lift or break. Yet, as always, individuals vary in their preferences, attitudes, and aesthetic impressions.

### 50.1 Ergonomic Design Benefits

- Improved safety
- Legal compliance

### 50.2 Consequences of Not Using Ergonomic Design

- Lost time
- Increased cost
- Injury, illness
- Disease
- Fatality

### 50.3 Solar Control

- Solar control will be the second most important function of the enclosure in tomorrow’s office, since both solar overheating and glare control are significant concerns in the electronic workplace.
- A number of existing and emerging enclosure components and assemblies deal directly with the following concerns:
  - low-heat gain, high-light gain glass
  - glazings for high sun-angle reflection, low sun penetration
  - interior shading devices: blinds, roll-down reflecting/diffusing screens
  - exterior shading devices: blinds, roll-down screens, overhangs, awnings, vegetation, glazing louvers
  - integral shading devices: slimshades with air extract, dynamic electrochromic glazings, photochromic glazings
  - vented enclosures: rainscreens, double roofs
  - mechanical penthouse shading, air-intake shading

#### 50.3.1 Solar Overheating

- The quick response to solar overheating is to reduce window surface area and use highly reflective glass. This reaction, however, has severe consequences, removing office workers from light, view, outdoor contact, and sense of season and time of

day. (Even plants suffer under these conditions.) In addition, this response creates increased brightness contrast problems at the perimeter, creating “bright holes in a dark field.”

### 50.3.2 Glazings

- Utilize glazings that provide high reflectivity without diminishing light gain and view, thereby incorporating the best thermal and visual qualities in a single component (e.g., Azurlite™, Frit™).
- Glazings that offer clear views and high light gain can be combined with interior or exterior shading devices, such as diffusing screens or blinds, to provide more options and give even better long-term energy performance.

## 51.1 The Safety Manager's Role in Integrating Ergonomics with Project Management

Safety managers should promote ergonomics in order to:

- Create opportunity.
- Widen exposure.
- Secure special assignments.
- Facilitate consideration of ergonomics at high-level meetings.

They should:

- Provide current information.
- Create learning opportunities.
- Hold “What if?” sessions.
- Ask, “What would you do in this situation?”
- Provide greater access to resources.
- Criticize when appropriate and constructive.

## 51.2 Key Issues for Success

A safety management ergonomics program must address and resolve many complicated ergonomic issues:

- Commitment and attitude of upper management
- Relevance of program to department, division, and corporate goals at any given point in time
- Flexibility of implementation methods
- In-house accounting, procurement, inventory, and distribution processes versus budget and implementation requirements
- Overall financial condition of company
- Overall financial priority of ergonomics versus other safety program
- Workload of employees who are responsible for implementing ergonomics requirements

### 51.3 The World of Safety Management and Ergonomics

- ❑ The world of safety management is changing, and with it the demands of form and function to involving human factor and work.

#### 51.3.1 Demographic and Legal Changes

Demographic and legal changes are requiring organizations to act more humanistically.

- ❑ The growing labor shortage will require corporations to recruit people who did not work in the previous decades, and to creatively retain and redeploy existing labor.
- ❑ This accelerated change is pushing organizations to use self-managed work teams and interdisciplinary product development teams to avoid delays in making decisions.
- ❑ The U.S. labor supply will increase less than 1% per year, the slowest growth since the 1940s.
- ❑ Job sharing programs are offered by 16% of U.S. companies.

#### 51.3.2 Legal Authorities

Regulatory agencies

- Department of Labor
- Department of Transportation
- Environmental Protection Agency
- Department of Health and Human Services
- National Institute for Occupational Safety and Health
- Occupational Safety and Health Administration

Regulatory acts and laws

- The Americans with Disabilities Act
- The Clean Air Act
- The Clean Water Act
- Federal Insecticide, Fungicide, and Rodenticide Act
- Federal Railroad Safety Act
- Flammable Fabrics Act
- Hazardous Materials Transportation Act
- The National Energy Policy Act
- The Noise Control Act
- Poison Prevention Packaging Act
- The Ports and Waterways Safety Act
- Resource Conservation and Recovery Act
- Toxic Substance Control Act

### 51.3.3 Economic Parameters

Architects are subject to increasingly stringent economic parameters.

- ❑ Home-based businesses in the United States are on the increase.
- ❑ Computers are turning structures into “smart” buildings that monitor and run themselves—and connect occupants with the rest of the world.
  - Mitsubishi Real Estate connected 22 buildings in Tokyo’s Marunouchi district with a network of optic fibers. If enough smart buildings are interconnected, a “smart city” will be created, which can be linked to other smart cities of the future.
- ❑ Working part-time continues to be a popular option.

### 51.3.4 Technological Change, Compressed Product Cycles, and Global Competition

The major themes of the 1990s were technological change, compressed product cycles, and global competition.

- ❑ Between 1970 and 1986, the number of people employed by temporary-help firms grew from 184,000 to 760,000.
- ❑ Flexible work schedules were available to more workers.
- ❑ Almost nine million workers—1 out of every 12—were spending at least eight hours per month working at home during normal work hours.

### 51.3.5 Telecommunications

- ❑ Improved telecommunications permit us to do business from home with a Tokyo office or a rural location in Indiana, almost as if we are sitting across a table, sharing conversation and documents.
- ❑ New technologies have changed the importance of scale and location and have extended the power of the individual.
- ❑ Computers, cellular phones, and fax machines (9 million) empower individuals and make them more productive and efficient.
- ❑ Groupware—a new type of software (IBM-TeamFocus, Lotus-Notes, Ventana-Group Systems, Collaborative Technologies-VisionQuest)—is linking departments and colleagues in different locations to improve the efficiency, quality, and speed of collaborative projects.

### 51.3.6 Education

- ❑ One-quarter of the workforce age 25 to 64 consists of college graduates or higher, twice the amount of 20 years ago.
- ❑ Another 20% have had one to three years of college, more than double the old amount. That means nearly half—about 45%—of the workforce is college educated. In addition, 40% are high school graduates. That leaves just 15% who are adult age without a high school diploma. Twenty years ago, 41% had not completed high school.

Safety managers faced with all of these demographic and physical changes and challenges must be creative in designing new work environments.



# Glossary

---



**Abduction:** Movement away from the body midline. For example, shoulder abduction refers to the movement of the elbow away from the body, resulting in an increased angle at the shoulder joint. *Adduction* is the opposite term.

**Accessibility:** The ease with which parts can be accessed when performing a preventive maintenance or repair activity.

**Administrative Control:** Procedures and methods set up by the employer, which significantly reduce exposure to risk factors by altering the way in which work is performed; examples include employee rotation, job task enlargement, and adjustment of work pace.

**American National Standards Institute (ANSI):** ANSI has been responsible for the development of design guidelines for computer workstations (ANSI/HFS 100-1988) and draft guidelines for ergonomics (ANSI Z365).

**Analog Display:** A display requiring some level of interpretation of information on the part of the user. For example, a temperature gauge that has colored zones indicating acceptable and unacceptable temperature regions is an analog display. The opposite of an analog display is a *digital display*.

**ANSI B11 Technical Report:** Ergonomic Guidelines for the Design, Installation and Use of Machine Tools. The Machine Tool Safety Standards Committee (B11) of the American National Standards Institute took the initiative in the early 1990s to compose this voluntary standard involving the design, installation, and use of tools/machines from an ergonomics perspective to reduce workplace injury and improve product production.

**Anthropometry:** The study and measurement of human physical dimensions.

**Anti-Fatigue Mats:** Mats or padding on the floor designed to reduce stresses on the feet and leg across the work shift. Cushioned insoles for shoes can be viewed as “portable anti-fatigue mats.”

**Asymmetry:** Refers to twisting motions by the body, or unequal loading on different body parts.

**Awkward Posture:** Posture is the position of the body while performing work activities. Awkward posture is associated with an increased risk for injury. It is generally considered that the more a joint deviates from the neutral (natural) position, the greater the risk of injury. Specific postures associated with injury include the following: *wrist*: flexion/extension (bending up and down), ulnar/radial deviation (side bending); *shoulder*: abduction/flexion (upper arm positioned out to the side or above shoulder level), hands at or above shoulder height; *neck (cervical spine)*: flexion/extension or bending the neck forward and to the back, side bending (as when holding a telephone receiver on the shoulder); *low back*: bending at the waist, twisting.

**Biomechanics:** The study of the effects of internal and external forces on the human body in movement and at rest. Biomechanical models calculate physical stresses occurring at the disks in the low back and at various body joints. The stresses are compared with accepted limits for compressive forces.

**Bursitis:** Bursae are lubricating pads separating tendons from bones in parts of the body. Bursitis is the result of the inflammation of a bursa. The inflammation may be caused by repetitive or forceful exertions at that joint.

**Carpal Tunnel Syndrome (CTS):** A specific cumulative trauma disorder (CTD) occurring as the result of compression on the median nerve that travels through the carpal tunnel in the wrist. Symptoms can include tingling and numbness in the hand, and loss of dexterity and strength in the hand.

**Contact Stress:** Exposure of a body part to a hard or sharp surface/edge at a workstation or tool. Contact stress has been associated with the development of cumulative trauma disorders (CTDs).

**Contrast:** Difference between the lighter and darker areas of (for example) a computer monitor.

**Control:** Any device manipulated by the user that allows the user to interact with the system.

**Coupling:** The interface between the hands and an object lifted or control manipulated.

**Cumulative Trauma:** Term used for injuries that occur over a period because of repeated trauma or exposure to a specific body part, such as the back, hand, wrist, and forearm. Muscles and joints are stressed, tendons are inflamed, nerves pinched, or the flow of blood is restricted. Common occupationally induced disorders in this class include carpal tunnel syndrome, epicondylitis (tennis elbow), tendinitis, tenosynovitis, synovitis, stenosing tenosynovitis of the finger, DeQuervain's syndrome, and low back pain.

**Cumulative Trauma Disorder (CTD):** A bodily injury caused by the buildup of mechanical stressors over time. Specifically, it is a health disorder arising from repeated biomechanical stress due to ergonomic hazards.

**Damaging Wrist Motion (DWM):** Damaging wrist motions are defined as hand motions coupled with force.

**Deviation:** Movement of a body part toward the extreme in its range of motion. For example, ulnar deviation of the wrist describes the movement of the wrist away from a straight position toward the ulna bone in the forearm.

**Disability:** Under the Americans with Disabilities Act (ADA), an individual with a disability is a person who has a physical or mental impairment that substantially limits one or more major life activity; has a record of such impairment; or is regarded as having such impairment.

**Display:** A device that provides feedback to an operator regarding the status of a machine. Displays can take many different forms and can use different sense modalities (e.g., vision, hearing) to provide their feedback.

**Duration:** The continuous time a task is performed without a sufficient rest period.

**Engineering Control:** Physical changes to jobs that control exposure to risk. Engineering controls act on the source of the hazard and control employee exposure to the hazard without relying on the employee to take self-protective action or intervention. Examples include changing the handle angle of a tool, using a lighter weight part, and providing a chair that has adjustability.

**Ergonomic Hazards:** Workplace conditions that pose a biomechanical stress to the worker.

**Ergonomics:** A discipline dealing with the interaction between the worker and the work environment.

**Ergonomics Program:** Application of ergonomics in a structured system including the following components: health and risk factor surveillance, job analysis and design, medical management, and training.

**Extension:** Movement at a joint that increases the angle at that joint.

**Flexion:** Movement at a joint that reduces the angle at that joint.

**Flicker (Refresh Rate):** The perceived movement of characters on the screen. Flicker can be a function of the refresh rate of the display, defined as the number of times per second that an electron beam returns to a defined point on the screen to re-excite the phosphor and repaint the screen.

**Fonts:** Types of character designs used in labels, computer monitors, and so on.

**Footrest:** A support located below the workstation that enables the worker to either rest his or her feet at a standing workstation or rest both feet at a seated workstation.

**Force:** The amount of muscular effort required to perform a task. Generally, the greater the force is, the greater the degree of risk. High force has been associated with Work-Related Musculoskeletal Disorders of the shoulder/neck, the low back, and the forearm/wrist/hand.

**Forearm Rotation:** Rotational movement of the forearm at the elbow joint (e.g., when working a screwdriver). Rotating the forearm so that the palm of the hand is facing down is referred to as *pronation*. Rotating the forearm so that the palm is up is referred to as *supination*.

**Functional Working Height:** The actual position of the hands when performing a task. Depending on the height of the objects handled, the functional working height may not be the same as the shelf or workstation height.

**Health Surveillance:** Component of an ergonomics program consisting of the ongoing and systematic collection and analysis of health and exposure data. Consists of both active and passive surveillance; used to quantify the presence and magnitude of injury and ergonomic issues in jobs.

**Heat Stress:** Exposure to a hot environment that reduces the capability for sustained activity and speeds up fatigue.

**Horizontal Line of Sight:** A horizontal line drawn from the eye of the worker. Workers should not have to perform intensive visual activities above the horizontal line of sight.

**Human Factors:** A term synonymous with *ergonomics*. Human factors is the branch of ergonomics that began in the United States and focuses on cognitive performance of humans.

**Illuminance:** A measure of the amount of light falling on or incident to a defined surface (typically measured in lux or foot-candles). *Luminance* is a corresponding measure of the amount of light emitted from a light source.

**Incidence Rate:** The number of injuries (incidents) that occur over a period of time, typically expressed as the number of incidents per 200,000 worker-hours.

**International Standards Organization (ISO):** Office work with the video display terminal is written as a standard of usability as an ergonomic standard in ISO 9241.

**L5/S1:** The intervertebral disk between the fifth lumbar (L5) and first sacral (S1) vertebrae of the spinal column.

**Ligaments:** Fibrous structures that connect bones to bones within the body, providing support while allowing flexibility and movement.

**Lux:** A measure of luminance. One lux equals 0.093 foot-candles.

**Maintainability:** Equipment design focused on the achievement of some specific capability.

**Maintenance:** All of the technical activities that are devoted to the upkeep of equipment.

**Major Life Activity:** Activities that an average person can perform with little or no difficulty, such as walking, speaking, breathing, performing manual tasks, seeing, hearing, learning, caring for oneself, working, sitting, standing, lifting, and reading. These are examples only.

**Manual Materials Handling (MMH):** Manual materials handling refers to any handling task involving the human body as the “power source.” MMH includes lifting, lowering, pushing, pulling, carrying, and holding.

**Median Nerve:** The nerve that travels through the carpal tunnel of the wrist and services the thumb and first three fingers of the hand. Compression of the median nerve is the definition of carpal tunnel syndrome.

**Mental Impairment:** A mental impairment is defined by the Americans with Disabilities Act as “any mental or psychological disorder, such as mental retardation, organic brain syndrome, emotional or mental illness, and specific learning disabilities.”

**Motion–Velocity/Acceleration:** *Velocity* is the speed of body part motion and *acceleration* is the rate of change of speed of body part motion. It is generally regarded that increased acceleration leads to increased risk of injury.

**Muscle Sprain:** A torn muscle fiber. Typically the tear is microscopic.

**Musculoskeletal Disorders (MSD):** Injuries and disorders of the muscles, nerves, tendons, ligaments, joints, cartilage, and spinal disk; examples include carpal tunnel syndrome, rotator cuff tendinitis, and tension neck syndrome.

**Neutral Posture:** The body position that minimizes stresses on the body. Typically the neutral posture will be near the midrange of any joint’s range of motion.

**NIOSH Equation:** The National Institute of Occupational Safety and Health (NIOSH) 1981 and 1991 guidelines consist of a series of mathematical equations based on historical injury data and related job data. The equations calculate recommended maximum safe weights of lift.

**Occupational Biomechanics:** A science concerned with the mechanical behavior of musculoskeletal tissues when physical work is performed.

**Occupational Illness:** Any abnormal condition or disorder, other than one resulting from an occupational injury, caused by exposure to factors associated with employment. It includes acute and chronic illnesses or disease, which may be caused by inhalation, absorption, ingestion, or direct contact. The broad categories of occupational illnesses are skin diseases and disorders, dust diseases of the lungs, respiratory conditions due to toxic agents, poisoning (systemic effects of toxic materials), disorders due to physical agents other than toxic materials, and disorders from repeated trauma.

**Occupational Injury:** Any injury such as a cut, fracture, sprain, amputation, and so on, that results from a work-related event or from a single instantaneous exposure in the work environment. Examples of injuries or disorders that can be work related include carpal tunnel syndrome (CTS), rotator cuff syndrome, DeQuervain’s syndrome, trigger finger, tarsal tunnel syndrome, sciatica, epicondylitis, tendinitis, Raynaud’s phenomenon, carpet layer’s knee, and herniated spinal disk.

**Occupational Safety and Health Administration (OSHA):** The mission of the Occupational Safety and Health Administration (OSHA) is to save lives, prevent injuries, and protect the health of America’s workers. To accomplish this, federal and state governments must

work in partnership with the more than 100 million working men and women and their six and a half million employers who are covered by the Occupational Safety and Health Act of 1970.

**Optimal Viewing Angle:** The range from the horizontal viewing distance down to 45 degrees below horizontal.

**OSHA 300 Log:** An OSHA-required form for employers to record and classify occupational injuries and illnesses, and note the extent of each case.

**Physical Impairment:** A physical impairment is defined by the Americans with Disabilities Act (ADA) as “any disorder, or condition, cosmetic disfigurement, or anatomical loss affecting one or more of the following body systems: neurological, musculoskeletal, special sense organs, respiratory (including speech organs), cardiovascular, reproductive, digestive, genito-urinary, hemic and lymphatic, skin, and endocrine.”

**Pinch Grip:** One of several types of grips that do not allow the hand to fully encircle the object being handled. Pinch grip types include tip pinches (tip of thumb against tip of index finger), pulp pinches (flat surface of thumb against flat surface of index finger), lateral pinches (thumb against side of index finger as when turning a key), and others.

**Pixel:** One of several dots that compose a character on a video display terminal (VDT).

**Polarity:** *Standard polarity* on a screen is light characters on a dark background. *Reverse polarity* is dark characters on a light background.

**Power Grip:** A grip allowing the four fingers and thumb to encircle the object. This grip will generally maximize power on the part of the worker.

**Pronation:** Rotation of the forearm such that the palm faces down or back.

**Psychophysical:** Having subjects select their maximum acceptable weight of handling under experimental conditions collects psychophysical data. Subjects adjust the weight handled until they feel the weight is not excessive. These selected weights represent design guidelines.

**Range of Motion:** The limits of movement defined at a joint or landmark of the body. Stresses on the connective tissues at a joint increase as the joint moves toward the limit of its range of motion.

**Rate of Perceived Exertion (RPE):** A scale filled out by workers that allows them to estimate the level of physical exertion associated with a task.

**Recommended Weight of Lift (RWL):** Recommended Weight of Lift (RWL) is computed using the NIOSH equation. The RWL reflects the weight that can be safely handled by 99% of males and 75% of females based on the task conditions.

**Recovery Time:** Recovery time is the length of rest between exertions. Short work pauses can reduce discomfort. Inadequate rest periods between exertions can decrease

performance. As the duration of the uninterrupted work increases, so does the amount of recovery time needed.

**Repetition:** Repetition is a number of similar exertions performed during a task. Repetitive motion has been associated with injury and worker discomfort. Generally, the greater the number of repetitions, the greater the degree of risk. However, there is no specific repetition limit or threshold value (cycles/unit of time, movements/unit of time) associated with injury.

**Repetition Rate:** The average number of movements or exertions performed by a joint or a body link within a unit of time. A warehouse worker may lift three boxes per minute from the floor to a countertop; an assembly worker may make 20 units per hour.

**Resonance:** The tendency of the human body to act in concert with externally generated vibration at selected vibration frequencies, which actually amplifies the incoming vibration and exacerbates its effects.

**Rest Period:** A contiguous period of time not spent performing any tasks. This may be a lunch break or a work break. Part of the measure of recovery time.

**Risk Factors:** Conditions of a job, process, or operation that contribute to the risk of developing cumulative trauma disorders (CTDs). Risk factors are regarded as synergistic elements of ergonomic hazards that must be considered in light of their combined effect in inducing CTDs.

**RMI:** Repetitive motion injury.

**Root-mean-square (rms):** The square root of the average value of the square of the acceleration record; the preferred method of quantifying the severity of human vibration exposures based on the convenience of measurements and analysis and the harmonization with some other areas of engineering.

**RSI:** Repetitive strain injury.

**Segmental Vibration (Hand-Arm Vibration):** Vibration applied to the hand/arms through a tool or piece of equipment. This can cause a reduction in blood flow to the hands/fingers (Raynaud's disease or vibration white finger). Also, it can interfere with sensory receptor feedback, leading to increased handgrip force to hold the tool. Further, a strong association has been reported between carpal tunnel syndrome and segmental vibration.

**Sharp Edge:** An edge on a work surface that applies pressure to the wrist, forearm, or elbow of the worker when it is resting on it. An operational criterion (in terms of radius of curvature) for what constitutes a sharp edge is not available in the literature.

**Sit/Stand:** A workstation that enables the worker to perform tasks at a standing position while still providing some support of a seated workstation.

**Static Load:** Stresses on the body increase as a function of body parts remaining immobile for extended periods.

**Supination:** Rotation of the forearm such that the palm faces up or out.

**Tendinitis:** Tendons connect muscles to bones. Tendinitis is the result of the inflammation of tendons at a body part.

**Tenosynovitis:** Swelling and inflammation of the sheath that surrounds certain tendons. The sheath produces a lubricating fluid for the tendon; tenosynovitis results from a decreased capacity to produce this lubricating fluid.

**Tool Balancers:** Any type of external support for a tool (or object) that eliminates or reduces the amount of weight supported by the worker.

**Trigger Finger:** Tendons in the finger joints can swell due to overuse, “locking” the finger into a fixed position.

**Troubleshooting:** The decision-making process used by maintenance personnel to locate the source of a maintenance problem.

**UECTD:** Upper extremity cumulative trauma disorder.

**VDT:** Video display terminal (computer monitor).

**Vertebral Disk:** Disks separate the bones that make up the spinal column. They are fibrous structures filled with a pulpy, gelatinous matter. They function as shock absorbers for the spine. Disk-related injuries to the back result from deformation of the disks, including bulging and rupturing of the disks.

**Vibration:** Whole body vibration is vibration transmitted to the entire body through some support such as a vehicular seat or building floor. Segmental vibration is vibration locally applied to specific body parts such as the hands and arms from a vibrating hand tool.

**Vibration White Finger:** A condition where the blood vessels in the hand constrict, resulting in decreased blood flow. This disease is associated with the long-term use of vibrating tools (or from general exposure to vibration). Also referred to as Raynaud’s phenomenon.

**Warning:** Specific stimuli that alert a user to the presence of a hazard, thereby triggering processing of additional information regarding the nature, probability, and magnitude of the hazard. This additional information may be within the user’s memory or may be provided by other sources external to the user.

**Whole Body Vibration:** Exposure of the whole body to vibration (usually through the feet/buttocks when riding in a vehicle). Whole body vibration may increase the risk of injury, including low back pain and internal organ disruption.

**Work Cycle:** The work cycle consists of an exertion period and a recovery (or smaller exertion) period necessary to complete one sequence of a task, before the sequence is repeated. The work cycle may consist of several elements, such as move, place, and fasten.

**Work Cycle Recovery Period:** The time not spent performing a movement(s) or exertion(s) within one work cycle.

**Work-Related Musculoskeletal Disorder (WMSD, WRMSD):** Injuries and disorders of the muscles, nerves, tendons, ligaments, joints, cartilage, and spinal disk due to physical work activities or workplace conditions in the job. Examples include carpal tunnel syndrome related to long-term computer data entry, rotator cuff tendinitis from repeat overhead reaching, and tension neck syndrome associated with long-term cervical spine flexion.

**Work-Related Musculoskeletal Disorder Hazard:** Workplace conditions or physical work activities that cause or are reasonably likely to cause or contribute to a work-related musculoskeletal disorder.

**Workstation:** The entire area accessed by a worker when performing a specific task or job cycle.

**WRULD:** Work-related upper limb disorder.



# Bibliography

---



- Aeking, C. A., and R. Kuller. "The perception of an interior as a function of its colour." *Ergonomics* 15, no. 6 (1972): 645–654.
- Altman, J. W. "Classification of human error." In *Symposium on reliability of human performance in work*, edited by W. B. Askren, AMRL, TR 67–88, May 1967.
- . "Improvements needed in a central store of human performance data." *Human Factors* 6, no. 6 (1964): 681–686.
- Amell, T. K., S. Kumar, Y. Narayan, and H. C. Coury. "Effect of trunk rotation and arm position on gross upper extremity adduction strength and muscular activity." *Ergonomics* 43, no. 4 (2000): 512–527.
- American Conference of Governmental Industrial Hygienists. *Hand activity level TLV® physical agents*, 7th ed. Cincinnati, Ohio: ACGIH, 2001.
- Annett, J., and N. A. Stanton. *Task analysis*. London: Taylor & Francis, 2000.
- Anton, D., J. Rosecrance, L. Merlino, and T. Cook, T. "Prevalence of musculoskeletal symptoms and carpal tunnel syndrome among dental hygienists." *American Journal of Industrial Medicine* 42, no. 3 (2002): 248–257.
- Army Center for Health Promotion and Preventive Medicine, Aberdeen Proving Ground, Md. "Injuries in the military: A hidden epidemic." *American Journal of Preventive Medicine* 18, no. 1 (1996): 4–5.
- Askren, W. B., ed. *Symposium on reliability of human performance in work*, AMRL, TR 67–88, May 1967.
- Association for the Advancement of Medical Instrumentation. *2007 Resource Catalog*. Arlington, Va.: AAMI, 2007.
- Ayoub, M. M., and A. Mital. *Manual materials handling*. London: Taylor & Francis, 1998.
- Azer, N. Z., P. E. McNall, and H. C. Leung. "Effects of heat stress on performance." *Ergonomics* 15, no. 6 (1972): 681–691.
- Babski, K. L. "Quantification of the exposure-response relationships of the primary risk factors for carpal tunnel syndrome." PhD diss., Mississippi State University, 2000.
- Backaitis, S. H. *Biomechanics of impact injury and injury tolerances of the thorax-shoulder complex*. Troy, Mich.: Society of Automotive Engineers, 1994.
- Backs, R. W., and W. Boucsein. *Engineering psychophysiology issues and applications*. Mahwah, N.J.: Lawrence Erlbaum Associates, 2000.
- Balke, B. *Human tolerances*. Civil Aeromedical Research Institute, Federal Aviation Agency, Aeronautical Center, Oklahoma City, Report 62-6, April 1962.

- Barany, J. W. "The nature of individual differences in bodily forces exerted during a simple motor task." *Journal of Industrial Engineering* 14, no. 6 (1963): 332–341.
- Barnes, R. M., and M. E. Mundell. "A study of simultaneous symmetrical hand motions." University of Iowa, Iowa City, *Studies in Engineering*, Bulletin 17, 1939.
- Barter, J. T., L. Emanuel, and B. Truett. "A statistical evaluation of joint range area data." USAF, WADC, Technical Note 57-311, 1957.
- Boggs, D. H., and J. R. Simon. "Differential effect of noise on tasks of varying complexity." *Journal of Applied Psychology* 52, no. 2 (1968): 148–153.
- Broadbent, D. E. "Effect of noise on an 'intellectual' task." *Journal of the Acoustical Society of America* 30 (1958): 824–827.
- Brophy, M., L. Achimore, and J. Dawson. Reducing incidence of low-back injuries reduces cost. *American Industrial Hygiene Association Journal* 62 (2001): 508–511.
- Brown, J. S., and A. T. Slater-Hammel. "Discrete movements in the horizontal plane as a function of their length and direction." *Journal of Experimental Psychology* 39, no. 1 (1949): 84–95.
- Brown, J. S., E. W. Wieben, and E. B. Norris. "Discrete movements toward and away from the body in a horizontal plane." ONR, USN, SDC, Contract N5ori-57, Report 6, September 1948.
- Brown, O., and H. Hendrick. *Human factors in organizational design and management—V*. Amsterdam: Elsevier Science, 1996.
- Bureau of Labor Statistics. *Lost-worktime injuries and illnesses: Characteristics and resulting time away from work*. Washington, D.C.: Department of Labor, 1998, 36831.
- Burgess-Limerick, R., M. Mon-Williams, and V. L. Coppard. "Visual display height." *Human Factors and Ergonomics Society* 42, no. 1 (2000): 140–150.
- Burke, M. *Applied ergonomics handbook*. London: CRC Press, 1992.
- Burton, W., and D. Conti. "Disability management: Corporate medical department management of employee health and productivity." *Journal of Occupational and Environmental Medicine* 42 (2000): 1006–1012.
- Butler, B. P., and N. M. Allen. *Long-duration exposure criteria for head-supported mass*. USAARL Report No. 97-34, 1997.
- Byrns, G., T. Bierma, J. Agnew, and B. Curbow. "A new direction in low-back pain research." *American Industrial Hygiene Association Journal* 63 (2002): 55–61.
- Carnahan, B. J., M. S. Redfern, and B. A. Norman. "Designing safe job rotation schedules using optimization and heuristic search." *Ergonomics* 43, no. 4 (2000): 543–560.
- Casey, S. *Set phasers on stun*. Santa Barbara, Calif.: Aegean, 1998.
- Cekala, S., W. Beusse, B. Lepore, M. Scire, and A. James. *Physically demanding jobs: Services have little data on ability of personnel to perform*. Washington, D.C.: GAO/NSIAD, 1996, 96–169.
- Central Institute for Labour Protection. "The International Ergonomics Association recognized." *International Journal of Occupational Safety and Ergonomics*, 1999.
- Chaffin, D. B., and G. B. Anderson. *Occupational biomechanics*. New York: Wiley, 1991.
- Chaffin, D. B., J. Faraway, A. Arbor, X. Zhang, and C. Woolley. "Stature, age and gender effects on reach motion postures." *Human Factors* 42 (2000): 408–420.
- Chapanis, A. *The Chapanis Chronicles: 50 years of human factors research, education, and design*. Santa Barbara, Calif.: Aegean, 1999.
- Cherkin, D., D. Eisenberg, K. Sherman, W. Barlow, T. Kaptchuk, J. Street, and R. Deyo. "Randomized trial comparing traditional Chinese medical acupuncture, therapeutic massage, and self-care education for chronic low back pain." *Archives of Internal Medicine* 161 (2001): 1081–1088.

- Chibnall, J. T., R. C. Tait, and S. C. Merys. "Disability management of low back injuries by employer-retained physicians: Ratings and costs." *American Journal of Industrial Medicine* 38, no. 5 (2000): 529–538.
- Christensen, E. H. "Physiological valuation of work in the Nykroppa iron works." In *Ergonomics Society Symposium on Fatigue*, edited by W. F. Floyd and A. T. Welford. London: Lewis, 1953, 93–108.
- Committee on Human Factors. *Work-related musculoskeletal disorders report, workshop summary, and workshop papers*. Washington, D.C.: National Academies Press, 1999.
- Connolly, V., A. Pritchard, A. Bergeron, M. Mays, and V. Rice. *Measurement of the effectiveness of a screening tool to detect injuries and improve readiness among combat medic students*. Fort Sam Houston, Tex.: U.S. Army Medical Department Center and School, 2002.
- Consultants in Occupational Ergonomics. *Applied Laboratory Ergonomics Manual*. Canonsburg, Pa.: Job Smart System, 2000.
- . *Applied Office Ergonomics Manual*. Canonsburg, Pa.: Job Smart System, 2000.
- . *Ergonomic Design Guidelines for Engineers Manual*. Canonsburg, Pa.: Job Smart System, 2000.
- Corlett, E. N., and K. Mahadeva. "A relationship between a freely chosen working pace and energy consumption curves." *Ergonomics* 13, no. 4 (1970): 517–524.
- Corrigan, R. E., and W. J. Brogden. "The trigonometric relationship of precision and angle of linear pursuit-movements." *American Journal of Psychology* 62 (1949): 90–98.
- Craik, K. J. W. Psychological and physiological aspects of control mechanisms with special reference to tank gunnery, Part 1. Medical Research Council (Great Britain), Military Personnel Research Committee, B.P.C. 43/254, August 1943.
- Damon, A., H. W. Stoudt, and R. A. McFarland. *The Human Body in Equipment Design*. Cambridge, Mass.: Harvard University Press, 1966.
- Datta, S. R., and N. L. Ramanathan. "Ergonomics comparison of seven modes of carrying loads on the horizontal plane." *Ergonomics* 14, no. 2 (1971): 269–278.
- Davies, B. T. "Moving loads manually." *Applied Ergonomics* 3, no. 4 (1972): 190–194.
- Davies, C. T. M. "Cardiac frequency in relation to aerobic capacity for work." *Ergonomics* 1 (1968): 511–526.
- Dempster, W. T. "The anthropometry of body action." *Annals of the New York Academy of Sciences* 63 (1955): 559–585.
- Department of Defense. *Assessing Programs for Injury/Occupational Illness Prevention Practices and Initiatives*. Washington, D.C.: Department of Defense Injury/Occupational Illness Prevention Committee, 2001.
- . *Best Practice Approaches in Injury/Occupational Illness Surveillance, Research, Intervention, Models, and Prevention*. Washington, D.C.: Department of Defense Injury/Occupational Illness Prevention Committee, 2001.
- . *Human Engineering Design Criteria Standard*. (MIL-STD-1472F). Washington, D.C.: Department of Defense, 1999.
- Department of Health and Human Services. *Health, United States, 2002, with Chartbook on Trends in the Health of Americans*. Washington, D.C.: Department of Health and Human Services, Centers for Disease Control and Prevention, 2002.
- Department of Industrial Relations. *Easy Ergonomics: A Practical Approach for Improving the Workplace*. San Francisco: California Department of Industrial Relations, 1999.
- Deyo, R. A., and J. N. Weinstein. "Low back pain." *New England Journal of Medicine* 344, no. 5 (2001): 363–371.
- Dieën, J., and H. Toussaint. "Evaluation of the probability of spinal damage caused by sustained cyclic compression loading." *Human Factors* 39, no. 3 (1997): 469–480.

- Dimov, M., A. Bhattacharya, G. Lemasters, and M. Atterbury. "Exertion and body discomfort perceived symptoms associated with carpentry tasks: An on-site evaluation." *American Industrial Hygiene Association Journal* 61 (2000): 685–691.
- Dvorak, A., N. L. Merrick, W. L. Dealey, and G. C. Ford. *Typewriting Behavior*. New York: American Book Company, 1936.
- Ebadian, M., M. Allen, W. Krummen, and T. Tucker. *A technical guide for performing ROI analyses of USAF workplaces (Final Report)*. Miami: Florida International University, 2000.
- Edholm, O. G. *The Biology of Work*. New York: McGraw-Hill, 1967.
- Ehrlich, R. J. Chapter 11, *CALL Newsletter No. 01-15, Soldier's load and combat readiness*. Joint Readiness Training Center, Operations Group, Task Force, 2003.
- Ergonomics Program, University of California. "Estimating muscle load using surface EMG amplitude." Marconi Research Conference, 1998.
- Estill, C. F., J. D. McGlothlin, R. T. Hagedorn, and J. P. Flesch. *Hazard controls: Controlling the ergonomic hazards of wiring tasks for household appliances*. DHHS (NIOSH) Publication No. 98-108. Cincinnati, Ohio: NIOSH/DHHS, 1998.
- Faulkner, T. W., and T. J. Murphy. "Illumination: A human factors viewpoint." Paper presented at 15th annual meeting of Human Factors Society, 1971.
- . "Lighting for difficult visual tasks." *Human Factors* 15, no. 2 (1973): 149–162.
- Fleming, S. L., C. W. Jansen, and S. M. Hasson. "Effect of work glove and type of muscle action on grip fatigue." *Ergonomics* 40, no. 6 (1997): 601–612.
- Flinchum, R. "Dreyfuss, design, and human factors." *Ergonomics in Design* Q1 (Winter 2000): 18.
- Fogleman, M., and G. Brogmus. "Computer mouse use and cumulative trauma disorders of the upper extremities." *Ergonomics* 38, no. 12 (1995): 2465–2475.
- Fransson-Hall, C., R. Gloria, A. Kilborn, and J. Winkel. "A portable ergonomic observation method (PEO) for computerized on-line recording of postures and manual handling." *Applied Ergonomics* 26, no. 2 (1995): 93–100.
- Frey, J. H., and S. M. Oishi. *How to conduct interviews by telephone and in person*. Newbury Park, Calif.: Sage, 1995, 4.
- Friedrich, M., T. Cermak, and I. Heiller. "Spinal troubles in sewage workers: Epidemiological data and work disability due to low back pain." *International Archives of Occupational and Environmental Health* 73, no. 4 (2000): 245–254.
- Fulton Suri, J. "Saving lives through design." *Ergonomics in Design* 8, no. 3 (2000): 4–12.
- Gallagher, W. *The power of place: How our surroundings shape our thoughts, emotions, and actions*. New York: Poseidon, 2003.
- Gilbreth, F. *Motion study*. New York: Van Nostrand, 1911.
- Glencross, D. J. "Temporal organization in a repetitive speed skill." *Ergonomics* 16, no. 6 (1973): 765–776.
- Gordon, E. E. "The use of energy costs in regulating physical activity in chronic disease." *Archives of Industrial Health* 16, November 1957, 437–441.
- Gottsdanker, R. M. "The continuation of tapping sequences." *Journal of Psychology* 37 (1954): 123–132.
- Grajewski, B., T. M. Schnoor, and J. Reefhuis. "Work with video display terminals and the risk of reduced birthweight and preterm birth." *American Journal of Industrial Medicine* 32 (1997): 681–688.
- Grandjean, E. *Ergonomics in computerized offices*. London: Taylor & Francis, 1995.
- . *Fitting the task to the man: A textbook of occupational ergonomics*, 4th ed. London: Taylor & Francis, 1988.

- Grant, C., and M. Brophy. *An ergonomics guide to VDT workstations*. Fairfax, Va.: American Industrial Hygiene Association, 1994.
- Grant, K. A., J. J. Congleton, and R. J. Koppa. "Use of motor nerve conduction testing and vibration sensitivity testing as screening tools for carpal tunnel syndrome in industry." *Journal of Hand Surgery* 17A, no. 1 (1991): 71–76.
- Greenberg, L., and D. Chaffin. *Workers and their tools*. Midland, Mich.: Pendell, 1989.
- Greene, J. H., W. H. M. Morris, and J. E. Wiebers. "A method for measuring physiological cost of work." *Journal of Industrial Engineering* 10, no. 3, May–June 1959.
- Guo, H., S. Tanaka, W. Halperin, and L. Cameron. "Back pain prevalence in U.S. industry and estimates of lost workdays." *American Journal of Public Health* 89 (1999): 1029–1035.
- Guo, L., A. Genaidy, D. Christensen, and K. Huntington. "Macro-ergonomic risk assessment in nuclear remediation industry." *Applied Ergonomics* 27, no. 4 (1996): 241–254.
- Hadler, N. M. "Back pain in the workplace." *Spine* 22, no. 9 (1997): 935–940.
- Hagberg, M., B. Silverstein, R. Wells, R. Smith, P. Carayon, H. Hendrick, and M. Perusse. *Work-related musculoskeletal disorders (WMSDs): A reference book for prevention*. London: Taylor & Francis, 1995.
- Hansen, D. J. *The work environment, healthcare, laboratories, and biosafety*. Vol. 2. London: Lewis Publishers, 1993.
- Harman, E., K. H. Han, P. Frykman, and C. Pandorf. *The effects of walking speed on the biomechanics of backpack load carriage*. Natick, Mass.: U.S. Army Research Institute of Environmental Medicine, 2000.
- Harris, S. J., and K. U. Smith. "Dimensional analysis of motion: VII. Extent and direction of manipulative movements as factors in defining motions." *Journal of Applied Psychology* 38 (1954): 126–130.
- Harston, L. D. "Contrasting approaches to the analysis of skilled movements." *Journal of General Psychology* 20 (1939): 263–293.
- Hilgendorf, L. "Information input and response time." *Ergonomic* 9, no. 1 (1966): 31–37.
- Hoogendoorn, W. E., M. N. M. van Poppel, P. M. Bongers, B. W. Koes, and L. M. Bouter. "Physical load during work and leisure time as risk factors for back pain." *Scandinavian Journal of Work, Environment and Health* 25, no. 5 (1999): 387–403.
- Hoskin, A. F. *National Safety Council case studies in safety productivity*. Washington, D.C.: National Safety Council, 2000.
- Hunsicker, P. A. "Arm strength at selected degrees of elbow flexion." USAF, WADC, TR 54-548, August 1955.
- Institute of Medicine. *Crossing the quality chasm: A new health system for the 21st century*. Washington, D.C.: National Academies Press, 2001.
- International Ergonomics Association. Abstracts from the First International Symposium on Ergonomics in Building and Construction. CPWR and NIOSH, 1997.
- International Labour Office, Geneva. *Ergonomic checkpoints*. Geneva: International Labour Organization, 1996.
- International Occupational Safety and Health Information Centre. *Manual lifting and carrying*. CIS Information Sheet 3. Geneva: International Occupational Safety and Health Information Centre, 1962.
- International Organization for Standardization. *Ergonomic requirements for office work with visual display terminals (VDTs)*. Geneva: International Organization for Standardization, 1997.
- Irwin, L. A., J. J. Levitz, and A. M. Freed. "Human reliability in the performance of maintenance." In *Proceedings, Symposium on quantification of human performance, August*

- 17–19, 1964, Albuquerque, New Mexico: Subcommittee on Human Factors, Electronic Industries Association, 1964, 143–198, M-5.7.
- Jacobs, K. *Ergonomics for therapists*, 2nd ed. Boston: Butterworth-Heinemann Medical, 1999.
- Jones, B. H., M. W. Bovee, J. M. Harris, and D. N. Cowan. “Intrinsic risk factors for exercise-related injuries among male and female Army trainees.” *American Journal of Sports Medicine* 21, no. 5 (1993): 705–710.
- Jones, B. H., D. N. Cowan, and J. J. Knapik. “Exercise, training, and injuries.” *Sports Medicine* 18, no. 3 (1994): 202–214.
- Jones, B. H., D. N. Cowan, J. P. Tomlinson, J. R. Robinson, D. W. Polly, and P. N. Frykman. “Epidemiology of injuries associated with physical training among young men in the Army.” *Medicine and Science in Sports and Exercise* 25, no. 1 (1993): 197–203.
- Josephson, M., G. Pernold, G. Ahlberg-Hulten, and A. Harenstam. “Differences in the association between psychosocial work conditions and physical work load in female- and male-dominated occupations.” *American Industrial Hygiene Association Journal* 60 (1999): 673–678.
- Joyce, M., A. J. Marcotte, and R. Barker. “A methodology for identifying ergonomics risk factors and measuring the results of implementation of corrective actions.” Unpublished.
- Joyce, M., A. J. Marcotte, V. Calvez, and R. Barker. “A methodology for administrative work areas: Applications in a diverse multi-task environment.” Unpublished.
- Kallio, M., E. Viikari-Juntura, M. Hakkanen, and E. P. Takala. “Assessment of duration and frequency of work tasks by telephone interview: Reproductivity and validity.” *Ergonomics* 43, no. 5 (2000): 610–621.
- Kantowitz, B. H., and R. D. Sorokin. *Human factors: Understanding people-system relationships*. New York: Wiley, 1983.
- Karhu, O., and P. Kansil. “Correcting work postures in industry: A practical method for analysis.” *Applied Ergonomics* 8, no. 4 (1977): 199–201.
- Karqvist, L., M. Hagbert, and K. Selin. “Variation in upper limb posture and movement during word processing with and without mouse use.” *Ergonomics* 37, no. 7 (1994): 1261–1267.
- Karwowski, W., and P. Dempsey. *Ergonomics and musculoskeletal disorders*. Santa Monica, Calif.: Human Factors and Ergonomics Society, 1990.
- Karwowski, W., A. Genaidy, R. Huston, S. Yeung, and J. Beltran. “Development of the quantitative model for applications of workers’ expertise in evaluating manual lifting tasks.” *Proceedings of the HFES 43rd Annual Meeting*. Santa Monica, Calif.: Human Factors and Ergonomics Society, 1999, 647–651.
- Karwowski, W., and W. S. Marras. *The Occupational Ergonomics Handbook*. London: CRC Press, 1999.
- Karwowski, W., M. Wogalter, and P. Dempsey. *Ergonomics and musculoskeletal disorders: Research on manual materials handling, 1983–1996*. Santa Monica, Calif.: Human Factors and Ergonomics Society, 1997.
- Kasdan, M. L. *Occupational hand and upper extremity injuries and diseases*. New York: Hanley & Belfus, 1998.
- Kawakami, M., F. Inoue, and T. Ohkubo. “Evaluating elements of the work area in terms of job redesign for older workers.” *International Journal of Industrial Ergonomics* 25 (2000): 525–533.
- Kaye, R., and J. Crowley. *Medical device use—safety: Incorporating human factors engineering into risk management*. Washington, D.C.: Department of Health and Human Services, Center for Devices and Radiological Health, 1999.
- Keller, J. J. *Ergonomics: A step-by-step program developer*. Also has a VHS tape, *Ergonomics: What employees need to know*. Neenah, Wis.: J. J. Keller & Associates, 2001.

- Kemmlert, K. "Economic impact of ergonomic intervention: Four case studies." *Journal of Occupational Rehabilitation* 6, no. 1 (1996): 1–90.
- . *A method assigned for the identification of ergonomic hazards: PLIBEL*. Cincinnati, Ohio: National Institute for Occupational Safety and Health, 1995, 199–211.
- Keogh, J., P. Gucer, J. Gordon, and I. Nuwayhid. "Patterns and predictors of employer risk-reduction activities (ERRAs) in response to a work-related upper extremity cumulative trauma disorder." *American Journal of Industrial Medicine* 38 (2000): 489–497.
- Key, G. L. *Industrial therapy*. Saint Louis, Mo.: Mosby-Yearbook, 1995.
- Keyserling, W. M. "OWAS and RULA: Observational approaches to posture and work analysis." Unpublished, 1994.
- . "Sampling strategies for ergonomic job analysis." Unpublished, 1994.
- . "Workplace risk factors and occupational musculoskeletal disorders, Part 2: A review of biomechanical and psychophysical research on risk factors associated with upper extremity disorders." *American Industrial Hygiene Association Journal* 61, no. 2 (2000): 231–243.
- Keyserling, W. M., and T. J. Armstrong. "Occupational ergonomics." American Industrial Hygiene Conference and Exposition, 1992.
- Keyserling, W. M., T. J. Armstrong, and L. Punnett. "Ergonomic job analysis: A structured approach for identifying risk factors associated with overexertion injuries and disorders." *Applied Occupational and Environmental Hygiene* 6, no. 5 (1991): 353–363.
- Keyserling, W. M., D. S. Stetson, B. A. Silverstein, and M. Brouwer. "A checklist for evaluating ergonomic risk factors associated with upper extremity cumulative trauma disorders." *Ergonomics* 36, no. 7 (1993): 807–831.
- Khalil, T. M., E. M. Abdel-Moty, R. S. Rosomoff, and H. L. Rosomoff. *Ergonomics in back pain: A guide to prevention and rehabilitation*. New York: Van Nostrand Reinhold, 1993.
- Kilbom, A. Intervention programmes for work-related neck and upper limb disorders: Strategies and evaluations. *Ergonomics* 31, no. 5 (1988): 735–747.
- Kinoshita, H. "Effect of gloves on prehensile forces during lifting and holding tasks." *Ergonomics* 42, no. 10 (1999): 1372–1385.
- Kirwan, B., and L. K. Ainsworth. *A guide to task analysis*. London: Taylor & Francis, 1992.
- Kjellen, U. *Prevention of accidents through experience feedback*. London: Taylor & Francis, 2000.
- Knapik, J., P. Ang, K. Reynolds, and B. Jones. "Physical fitness, age, and injury incidence in infantry soldiers." *Journal of Occupational and Environmental Medicine* 35, no. 6 (1993): 598–603.
- Knapik, J. J., W. Harper, H. P. Crowell, K. Leiter, and B. Mull. "Standard and alternative methods of stretcher carriage: Performance, human factors, and cardiorespiratory responses." *Ergonomics* 43, no. 5 (2000): 639–652.
- Kohn, J. P. *The ergonomic casebook: Real world solutions*. London: Lewis Publishers, 1997.
- Kondratas, R. "Images from the history of the Public Health Service: A photographic exhibit." Department of Health and Human Services, 1994. [www.nlm.nih.gov/exhibition/phs\\_history/contents.html](http://www.nlm.nih.gov/exhibition/phs_history/contents.html)
- Konz, S., and S. Johnson. *Work design: Industrial ergonomics*, 5th ed. Scottsdale, Ariz.: Holcomb Hathaway, 1999.
- Krieger, G. R., and J. F. Montgomery. *Accident prevention manual for business and industry: Administration and programs*. Washington, D.C.: National Safety Council, 1992.
- Kroemer, K. H. E. "Avoiding cumulative trauma disorders in shops and offices." *American Industrial Hygiene Association Journal* 53, no. 9 (1992): 596–608.
- . *Ergonomic design of material handling systems*. London: Lewis Publishers, 1997.

- Kroemer, K. H. E., and E. Grandjean. *Fitting the task to the human: A textbook of occupational ergonomics*. London: Taylor & Francis, 1997.
- Kroemer, K. H. W., H. J. Kroemer, and K. E. Kroemer-Elbert. *Engineering physiology: Bases of human factors/ergonomics*. New York: Van Nostrand Reinhold, 1990.
- . *Ergonomics: How to design for ease and efficiency*. Upper Saddle River, N.J.: Prentice Hall, 1994.
- Kroemer, K. H. E., J. D. McGlothlin, and T. G. Bobick. *Manual material handling: Understanding and preventing back trauma*. Fairfax, Va.: American Industrial Hygiene Association, 1988.
- Kumar, S. "Rehabilitation: An ergonomic dimension." *International Journal of Industrial Ergonomics* 9 (1992): 97–108.
- Lauru, L. "The measurement of fatigue." *Manager* 22 (1954): 299–303, 369–375.
- LeBlanc, J. A. "Use of heart rate as an index of work output." *Journal of Applied Physiology* 10 (1957): 275–280.
- Lehman, K., J. Psihogios, and R. Meulenbroek. "Effects of sitting versus standing and scanner type on cashiers." *Ergonomics* 44, no. 7 (2001): 719–738.
- Lehmann, G. "Physiological measurements as a basis of work organization in industry." *Ergonomics* 1 (1958): 328–344.
- Lewis, J. R. "A critical literature review of human factors studies of split keyboards from 1926 to 1993." Unpublished, 1994.
- Li, G., and P. Buckle. "Current techniques for assessing physical exposure to work-related musculoskeletal risks, with emphasis on posture-based method." *Ergonomics* 42, no. 5 (1999): 674–695.
- Lie, I., and R. G. Watten. "VDT work, oculomotor strain, and subjective complaints: An experimental and clinical study." *Ergonomics* 37, no. 8 (1994): 1419–1433.
- Lincoln, A. E., J. S. Vernick, S. Ogaitis, G. S. Smith, C. S. Mitchell, and J. Agnew. "Interventions for the primary prevention of work-related carpal tunnel syndrome." *American Journal of Preventive Medicine* 18, no. 4 (2000): 37–50.
- Linton, S. J., A. L. Hellsing, and D. Andersson. "A controlled study of the effects of an early intervention on acute musculoskeletal pain problems." *Pain* 54 (1993): 353–359.
- Litwin, M. S. *How to measure survey reliability and validity*. Newbury Park, Calif.: Sage, 1995.
- Luczak, H., and W. Laurig. "An analysis of heart rate variability." *Ergonomics* 16, no. 1 (1973): 85–97.
- Luo, J., H. Sakakibara, S. Zhu, T. Kondo, and H. Toyoshima. "Effect of vibration magnitude and repetitive exposure on finger blood flow in healthy subjects." *International Archives of Occupational and Environmental Health* 73, no. 4 (2000): 281–284.
- Lynch, R., S. Mohr, and M. Gochfeld. "Prediction of tendinitis and carpal tunnel syndrome among solderers." *Applied Occupational and Environmental Hygiene* 12 (1997): 184–189.
- MacDonald, L., L. Karasek, L. Punnett, and T. Scharp. "Covariation between workplace physical and psychosocial stressors: Evidence and implications for occupational health research and prevention." *Ergonomics* 44, no. 7 (2001): 696–718.
- MacFarlane, G., M. Hunt, and A. Silman. "Role of mechanical and psychosocial factors in the onset of forearm pain: Prospective population-based study." *British Medical Journal* 321 (2000): 676–679.
- MacLeod, D. *The rules of work: A practical engineering guide to ergonomics*. London: Taylor & Francis, 2000.

- Manning, P., ed. *Office Design: A Study of Environment*. Pilkington Research Unit, Department of Building Science, University of Liverpool, Liverpool, England, SFB (92): UDC 725.23, 1965.
- . “Windows, environment, and people.” *Interbuild/Arena* (October 1967): 20–25.
- Margaria, R., F. Mangili, F. Cuttica, and P. Cerretelli. “The kinetics of the oxygen consumption at the onset of muscular exercise in man.” *Ergonomics* 8, no. 1 (1965): 49–54.
- Maynard, H. B. *Industrial Engineering Handbook*, 2nd ed. New York: McGraw-Hill, 1963.
- Mead, P. G., and P. B. Sampson. “Hand steadiness during unrestricted linear arm movements.” *Human Factors* 14, no. 1 (1972): 45–50.
- Meckel, E., M. Hagberg, I. Engkvist, and H. E. Wigaeus. “The prevention of back injuries in Swedish health care: A comparison between two models for action-oriented feedback.” *Applied Ergonomics* 28, no. 1 (1997): 1–7.
- Melhorn, J. M., L. Wilkinson, P. Gardner, W. Horst, and B. Silkey. “An outcomes study of an occupational medicine intervention program for the reduction of musculoskeletal disorders and cumulative trauma disorders in the workplace.” *Journal of Occupational and Environmental Medicine* 41, no. 10 (1999): 833–846.
- Melhorn, J. M., L. Wilkinson, and J. Riggs. “Management of musculoskeletal pain in the workplace.” *Journal of Occupational and Environmental Medicine* 43, no. 2 (2001): 82–93.
- Miles, D. W. “Preferred rates in rhythmic response.” *Journal of General Psychology* 16 (1937): 427–469.
- Miller, H. *Getting comfortable with technology*. Zeeland, Mich.: Herman Miller, 1992.
- . *Issues paper: Vision and the computerized office*. Zeeland, Mich.: Herman Miller, 1993.
- Miller, T., N. Pindus, J. Douglass, and S. Rossman. *Appendixes to databook on nonfatal injury incidence, costs, and consequences*. Washington, D.C.: Urban Institute Press, 1995.
- . *Databook on nonfatal injury incidence, costs, and consequences*. Washington, D.C.: Urban Institute Press, 1995.
- Milstein, R. L., and S. F. Wetterhall. “Framework for program evaluation in public health.” *Morbidity and Mortality Weekly Report* 48 (RR-11) (1999): 1–40.
- Mirka, G. A., D. P. Kelaher, D. T. Nay, and B. M. Lawrence. “Continuous assessment of back stress (CABS): A new method to quantify low-back stress in jobs with variable biomechanical demands.” *Human Factors* 42, no. 2 (2000): 209–225.
- Mital, A., and W. Karwowski. *Ergonomics in rehabilitation*. London: Taylor & Francis, 1988.
- Mital, A., A. S. Nicholson, and M. M. Ayoub. *A guide to manual materials handling*, 2nd ed. London: Taylor & Francis, 1997.
- Monk, T. H., and S. Folkard. *Making shiftwork tolerable*. London: Taylor & Francis, 1992.
- Moon, S. D., and S.L. Sauter. *Beyond biomechanics: Psychosocial aspects of musculoskeletal disorders in office work*. London: Taylor & Francis, 1996.
- Moore, J. S., and A. Garg. “The strain index: A proposed method to analyze jobs for risk of distal upper extremity disorders.” *American Industrial Hygiene Association Journal* 56 (1995): 443–458.
- . “Upper extremity disorders in a pork processing plant: Relationships between job risk factors and morbidity.” *American Industrial Hygiene Association Journal* 55, no. 8 (1994): 703–715.
- Moray, N. “Culture, politics and ergonomics.” *Ergonomics* 43, no. 7 (2000): 858–868.
- Morse, T., N. Warren, M. Cherniack, F. Fletcher, and D. Peterson. “The creation of ergonomic data sheets for hazard communication of work-related musculoskeletal disorders.” *Applied Occupational and Environmental Hygiene* 16, no. 8 (2001): 823–831.

- Moulton, B., and S. H. Spence. "Site-specific muscle hyper-reactivity in musicians with occupational upper limb pain." *Behaviour Research and Therapy* 30, no. 4 (1992): 375–386.
- Murphy, D. C., ed. *Ergonomics and the dental care worker*. Washington, D.C.: American Public Health Association, 1998.
- Murrell, K. F. H. *Human performance in industry*. New York: Reinhold, 1965.
- National Computer Systems, Inc. *Operator's Manual for the OpScan 3 and OpScan 4 Scanners*. Minneapolis, Minn.: National Computer Systems, 1997.
- National Institute for Occupational Safety and Health. "Control of ergonomic hazards from squeegee handles in the screen-printing industry." *Applied Occupational and Environmental Hygiene* 14, no. 12 (1999): 805–806.
- National Institute for Occupational Safety and Health. "Controlling the ergonomic hazards of wiring tasks for household appliances." *Applied Occupational and Environmental Hygiene* 14 (1999): 289–291.
- National Institute for Occupational Safety and Health. *Musculoskeletal disorders and workplace factors*. DHHS/NIOSH Publication No. 97-141. Cincinnati, Ohio: NIOSH, 1997.
- National Institute for Occupational Safety and Health. *NIOSH Publications on Video Display Terminals*, 3rd ed. DHHS/NIOSH Publication No. 99-135. Cincinnati, Ohio: NIOSH, 1999.
- National Institute for Occupational Safety and Health. *Occupational exposure to hand-arm vibration*. DHHS/NIOSH Publication No. 89-106. Cincinnati, Ohio: NIOSH, 1989.
- National Institute for Occupational Safety and Health. *Worker Health Chartbook, 2000*. NIOSH Publication No. 2000-127. Cincinnati, Ohio: NIOSH, 2000.
- National Institute for Occupational Safety and Health/Center for Disease Control. *Criteria for a recommended standard: Occupational exposure to hand-arm vibration*. DHHS (NIOSH) Publication No. 89-106. Cincinnati, Ohio: NIOSH, 1989.
- National Institute for Occupational Safety and Health, National Institute of Environmental Health Sciences, and U. S. Department of Energy. *Questions and answers: EMF in the workplace*. Washington, D.C.: U. S. Government Printing Office, 1996.
- National Research Council, Institute of Medicine. *Musculoskeletal disorders and the workplace: Low back and upper extremities*. Washington, D.C.: National Academies Press, 2001.
- National Safety Council. *Making the job easier: An ergonomics idea book*. Washington, D.C.: National Safety Council, 1988.
- Ness, S. A. *NIOSH Case Studies in Ergonomics*. Blue Ridge Summit, Pa.: Government Institutes, 1996.
- Neumann, W. P., R. P. Wells, R. W. Norman, D. M. Andrews, and J. Frank. "Comparison of four peak spinal loading exposure measurement methods and their association with low-back pain." *Scandinavian Journal of Work, Environment and Health* 25, no. 5 (1999): 404–409.
- Niebel, B. W. *Motion and time study*. Burr Ridge, Ill.: Irwin, 1993.
- Nordin, M., G. B. Anderson, and M. H. Pope. *Musculoskeletal disorders in the workplace: Principles and practices*. Saint Louis, Mo.: Mosby-Yearbook, 1997.
- Norman, R., R. Wells, P. Neumann, J. Frank, and H. Shannon. "A comparison of peak vs. cumulative physical work exposure risk factors for the reporting of low back pain in the automotive industry." *Clinical Biomechanics* 13 (1998): 561–573.
- Northup, J. *The promotable woman: What makes the difference*. Northup/Balibrera, 1985.
- Occupational Safety and Health Administration. *Ergonomics: Possible solutions; success stories*. Department of Labor, Occupational Safety and Health Administration. [www.osha.gov/SLTC/ergonomics/success\\_stories.html](http://www.osha.gov/SLTC/ergonomics/success_stories.html).

- Occupational Safety and Health Administration. *Ergonomics: Real people, real problems, real solutions*. Washington, D.C.: Department of Labor, 2000.
- Occupational Safety and Health Administration. "Ergonomics program: Proposed rule." *Federal Register* 64, no. 225, Part II (1999).
- Occupational Safety and Health Administration. *Ergonomics program management guidelines for meatpacking plants*. OSHA 3123. Washington, D.C.: Department of Labor, 1991.
- Occupational Safety and Health Administration. *Final ergonomics program standard - regulatory text*. This was published by OSHA on 24 Nov. 2000 and became effective 16 Jan. 01. However, PL 107-5 invalidated the std and OSHA removed from the CFR on 23 Apr. 01.
- Oh, S., R. G. Radwin, and F. J. Fronczak. "A dynamic mechanical model for hand force in right angle nutrunner operations." *Human Factors* 39, no. 3 (1997): 497–506.
- Pacific Environmental Services/The Joyce Institute. *Level 1 Ergonomic Assessment Methodology Guide for Administrative Work Areas*. Brooks Air Force Base, Texas: AL/OEMI, 1996. [https://portal.navfac.navy.mil/pls/portal/docs/PAGE/NAVFAC/NAVFAC\\_WW\\_PP/NAVFAC\\_HQ\\_PP/NAVFAC\\_SF\\_PP/NAVFAC\\_SF\\_RESOURCE/AGADMIN1.PDF](https://portal.navfac.navy.mil/pls/portal/docs/PAGE/NAVFAC/NAVFAC_WW_PP/NAVFAC_HQ_PP/NAVFAC_SF_PP/NAVFAC_SF_RESOURCE/AGADMIN1.PDF)
- Passmore, R. "Daily energy expenditure by man." *Proceedings of the Nutrition Society* 15 (1956): 83–89.
- Passmore, R., and J. V. G. A. Durnin. "Human energy expenditure." *Physiological Reviews* 35 (1955): 801–875.
- Pattie, C. "Simulated tractor overturnings: A study of human responses in an emergency situation." PhD diss., Purdue University, 1973.
- Provins, K. A. "Effect of limb position on the forces exerted about the elbow and shoulder joints on the two sides simultaneously." *Journal of Applied Physiology* 7 (1955): 387–389.
- Provins, K. A., and N. Salter. "Maximum torque exerted about the elbow joint." *Journal of Applied Physiology* 7 (1955): 393–398.
- Radwin, R. G., and J. T. Haney. *An ergonomics guide to hand tools*. Fairfax, Va.: American Industrial Hygiene Association, 1996.
- Randolph, J. "Carpal tunnel syndrome: Testing the sensitivity and validity of four 'localized discomfort' instruments." *American Association of Occupational Health Nurses Journal* 48, no. 8 (2000): 385–394.
- Ranney, D. *Chronic musculoskeletal injuries in the workplace*. Philadelphia: W.B. Saunders, 1997.
- Rayson, M., D. Holliman, and A. Belyavin. "Development of physical selection procedures for the British Army. Phase 2: Relationship between physical performance tests and criterion tasks." *Ergonomics* 43, no. 1 (2000): 73–105.
- Redfern, M. S., P. L. Moore, and C. M. Yarsky. "The influence of flooring on standing balance among older persons." *Human Factors* 39, no. 3 (1997): 445–455.
- Rempel, D., E. Serina, E. Klinenberg, B. J. Martin, T. J. Armstrong, J. A. Foulke, and S. Natarajan. "The effect of keyboard keyswitch make force on applied force and finger flexor muscle activity." *Ergonomics* 40, no. 8 (1997): 800–808.
- Reynolds, J. L., C. G. Drury, and R. L. Broderick. "A field methodology for the control of musculoskeletal injuries." *Applied Ergonomics* 25, no. 1 (1994): 3–16.
- Reynolds, K., H. Heckel, C. Witt, J. Martin, and J. Pollard. Cigarette smoking, physical fitness, and injuries in infantry soldiers. *American Journal of Preventive Medicine* 10, no. 3 (1994).
- Rice, V. J. *Ergonomics in health care and rehabilitation*. Amsterdam: Elsevier Science, 1998.

- Rice, V. J., V. Connolly, A. Bergeron, M. Mays, and G. M. Evans-Christopher. *Evaluation of a progressive unit-based running program during advanced individual training*. Fort Sam Houston, Tex.: U.S. Army Medical Department Center and School, 2002.
- Robson, L., H. Shannon, L. Goldenhar, and A. Hale. *Guide to evaluating the effectiveness of strategies for preventing work injuries: How to show whether a safety intervention really works*. Washington, D.C.: Department of Health and Human Service, 2001.
- Rockefeller, K. "Ergonomics demonstration project: Skilled nursing facility." *Applied Occupational and Environmental Hygiene* 17, no. 7 (2002): 470–474.
- Rodgers, S. H. "A functional job analysis technique." *Occupational Medicine* 7, no. 4 (1992): 679–711.
- . "An ergonomic approach to analyzing workplace accidents." *Applied Occupational and Environmental Hygiene* 15, no. 7 (2000): 529–534.
- Rogers, W. A. *Designing for an aging population: Ten years of human factors/ergonomics research*. Santa Monica, Calif.: Human Factors and Ergonomics Society, 1997.
- Roland, H. E., and B. Moriarty. *System safety engineering and management*. New York: Wiley, 1990.
- Rosecrance, J., K. Ketchen, L. Merlino, D. Anton, and T. Cook. "Test-retest reliability of a self-administered musculoskeletal symptoms and job factors questionnaire used in ergonomics research." *Applied Occupational and Environmental Hygiene* 17, no. 9 (2002): 613–621.
- Rucker, N., and J. S. Moore. "Predictive validity of the strain index in manufacturing facilities." *Applied Occupational and Environmental Hygiene* 17 (2002): 63–73.
- Rytkonen, E., and E. Sorainen. "Vibration of dental handpieces." *American Industrial Hygiene Association Journal* 62 (2001): 477–481.
- Safety Services of Texas. *Safety Clipart and Photographs on CD*. Austin: Safety Services of Texas, 1998.
- Salter, N., and H. D. Darcus. "The effect of the degree of elbow flexion on maximum torques developed in pronation and supination of the right hand." *Journal of Anatomy* 86 (1952): 197–202.
- Salvendy, G. *Handbook of human factors*, 2nd ed. New York: Wiley, 1997.
- Salvendy, G., and J. Pilitsis. "Psychophysiological aspects of paced and unpaced performance as influenced by age." *Ergonomics* 14, no. 6 (1971): 703–711.
- Salvendy, G., and M. J. Smith. *Human-computer interaction: Software and hardware interfaces. Proceedings of the Fifth International Conference on Human-Computer Interaction, Orlando, Florida, August 8–13, 1993*. Vol. 2. Amsterdam: Elsevier Science, 1993.
- Sanders, M. S., and E. J. McCormick. *Human factors in engineering and design*, 7th ed. New York: McGraw-Hill, 1993.
- Sauter, S. L., M. J. Dainoff, and M. J. Smith. *Promoting health and productivity in the computerized office*. London: Taylor & Francis, 1990.
- Scarlett, D., A. Chao, M. Bohan, J. Shores, and H. You. *Evaluation of the Wristcorder: A hand-forearm motion analyzer*. Wichita, Ks.: Wichita State University, 2000.
- Schappe, R. H. "Motion element synthesis: An assessment." *Perceptual and Motor Skills* 20 (1965): 103–106.
- Schmidtke, H., and F. Stier. "Der aufbau komplexer bewegungsabläufe aus elementarbewegungen." *Forschungsberichte des landes Nordrhein-Westfalen*, no. 822 (1960): 13–32.
- Schneid, T. D. *The Americans with Disabilities Act: A compliance manual*. New York: Van Nostrand Reinhold, 1992.
- . *The Americans with Disabilities Act: A practical guide for managers*. New York: Van Nostrand Reinhold, 1992.

- Schwartz, L. *Government manager's guide: Satisfaction surveys and performance improvements*. McLean, Va.: Logistics Management Institute, 1999.
- Seidel, H. "Selected health risks caused by long-term, whole-body vibration." *American Journal of Industrial Medicine* 23 (1993): 589–604.
- Seidel, H., and R. Heide. "Long-term effects of whole body vibration: A critical survey of the literature." *International Archives of Occupational and Environmental Health* 58, no. 1 (1986): 1–26.
- Shaffer, R. A. *Epidemiology of illness, injury, and attrition among select U.S. military female population*. San Diego, Calif.: Naval Health Research Center, 1995.
- Shahnavaz, H. "Role of ergonomics in the transfer of technology to industrially developing countries." *Ergonomics* 43, no. 7 (2000): 903–907.
- Shannon, S. G., J. P. Albano, and K. T. Mason. *Head injury risk in U.S. Army rotary-wing mishaps: Changes since 1980*. USAARL Report No. 98-13. Fort Rucker, Ala.: U.S. Army Aeromedical Research Laboratory, 1998.
- Sharp, M. A., V. J. Rice, B. C. Nindi, and T. L. Williamson. "Effects of team size on the maximum weight bar lifting strength of military personnel." *Human Factors* 39, no. 3 (1997): 481–488.
- Shaw, E., and S. L. Shepherd. *Office of Workers' Compensation Program (OWCP) data codebook*. San Diego, Calif.: Naval Health Research Center, 1993.
- Shaw, W. S., M. Feuerstein, A. E. Lincoln, V. I. Miller, and P. M. Wood. "Case management services for work-related upper extremity disorders: Integrating workplace accommodation and problem solving." *American Association of Occupational Health Nurses Journal* 49, no. 8 (2001): 378–389.
- Shephard, R. J. "Aging and productivity: Some physiological issues." *International Journal of Industrial Ergonomics* 25 (2000): 535–545.
- Shih, Y., M. Wang, and C. Chang. "The effect of valve handwheel type, operating plane, and grasping posture on peak torque strength of young men and women." *Human Factors* 39, no. 3 (1997): 489–496.
- Silverstein, B., J. Burt, J. Fernald, J. Kalat, C. Karr, J. Kaufman, M. Miller, D. Moore, D. Sebesta, and N. Villacres. *Upper extremity cumulative trauma disorders in a poultry processing plant: A preliminary report*. Olympia: Washington State Department of Labor and Industries, Safety and Health Assessment and Research for Prevention (SHARP) Program, 1991.
- . *Upper extremity cumulative trauma disorders in fish processing plants: A preliminary report*. Olympia: Washington State Department of Labor and Industries, Safety and Health Assessment and Research for Prevention (SHARP) Program, 1991.
- Silverstein, B., R. Hughes, J. Burt, J. Kalat, and J. Kaufman. *Cumulative trauma disorders at two fish processing plants: One-year follow-up survey*. Olympia: Washington State Department of Labor and Industries, Safety and Health Assessment and Research for Prevention (SHARP) Program, 1992.
- Silverstein, B., and J. Kalat. *Work-related disorders of the back and upper extremity in Washington State, 1989–1996: Technical report*. Olympia: Washington State Department of Labor and Industries, Safety and Health Assessment and Research for Prevention (SHARP) Program, 1998.
- Smith, M. J., and G. Salvendy. *Human-computer interaction: Applications and case studies*. Amsterdam: Elsevier, 1993.
- Snook, S. H. "The effects of age and physique on continuous-work capacity." *Human Factors* 13, no. 5 (1971): 467–479.
- Snook, S. H., and C. H. Irvine. "Psychophysical studies of physiological fatigue criteria." *Human Factors* 1, no. 3 (1969): 291–300.

- Snook, S. H., C. H. Irvine, and S. F. Bass. "Maximum weights and workloads acceptable to male industrial workers while performing lifting, lowering, pulling, carrying, and walking tasks." Paper presented to American Industrial Hygiene Conference, Denver, May 1969.
- Sommerich, C. M., S. M. B. Joines, and J. M. Psihogios. "Effects of computer monitor viewing angle and related factors on strain, performance, and preference outcomes." *Human Factors* 43, no. 1 (2001): 39–55.
- Stetson, D. S., W. M. Keyserling, B. A. Silverstein, and J. A. Leonard. "Observational analysis of the hand and wrist: A pilot study." *Applied Occupational and Environmental Hygiene* 6, no. 11 (1991): 927–937.
- Stewart, D. W., and P. N. Shamdasani. *Focus groups: Theory and practice*. Newbury Park, Calif.: Sage, 1990.
- Stiens, S. A., J. K. Haselkorn, and D. J. Peters. "Rehabilitation intervention for patients with upper extremity dysfunction: Challenges of outcome evaluation." *American Journal of Industrial Medicine* 29 (1996): 590–601.
- Stotko, L. "Rest breaks and stretching aid in stress reduction." *CTD News Workplace Solutions for Repetitive Stress Injuries*, September 1, 1999.
- Stramler, J. H. *The dictionary for human factors/ergonomics*. London: CRC Press, 1993.
- Strasser, H., K. Gruen, and W. Koch. "Office acoustics: Analyzing reverberation time and subjective evaluation." *Occupational Ergonomics* 2, no. 2 (1999): 67–80.
- Stuart-Buttle, C. "A discomfort survey in a poultry-processing plant." *Applied Ergonomics* 25, no. 1 (1994): 47–52.
- Switzer, S. A. "Weight-lifting capabilities of a selected sample of human males." AMRL, MRL, TDR 62-57. 1962.
- Tanaka, S., M. Petersen, and L. Cameron. "Prevalence and risk factors of tendinitis and related disorders of the distal upper extremity among U.S. workers: Comparison to carpal tunnel syndrome." *American Journal of Industrial Medicine* 39 (2001): 328–335.
- Thomae, M., J. Porteous, J. Brock, G. Allen, and R. Heller. "Back pain in Australian military helicopter pilots: A preliminary study." *Aviation, Space, and Environmental Medicine* 69 (1998): 468–473.
- Thomas, R. E., R. K. Butterfield, J. N. Hool, and R. T. Herrick. "Effects of exercise on carpal tunnel syndrome symptoms." *Applied Ergonomics* 24, no. 2 (1993): 101–108.
- Thomas, R. E., and S. C. Vaidya. "The effects of biofeedback on carpal tunnel syndrome." *Ergonomics* 36, no. 4 (1993): 353–361.
- Tichauer, E. R. "A pilot study of the biomechanics of lifting in simulated industrial work situations." *Journal of Safety Research* 3, no. 3 (1971): 98–115.
- Tomlinson, J., W. Lednar, and J. Jackson. "Risk of injury in soldiers." *Military Medicine* 152 (1987): 60–64.
- Torner, M., M. Cagner, B. Nilsson, and P. Nordling. "Occupational injury in Swedish fishery: Part 2. Promoting implementation of safety measures." *Occupational Ergonomics* 2, no. 2 (1999): 91–104.
- Torner, M., and P. Nordling. "Occupational injury in Swedish fishery: Part 1. Analysis of injury statistics." *Occupational Ergonomics* 2, no. 2 (1999): 81–89.
- Torner, M., C. Zetterberg, U. Anden, T. Hansson, and V. Lindell. "Workload and musculoskeletal problems: A comparison between welders and office clerks (with reference also to fishermen)." *Ergonomics* 34 (1991): 1179–1196.
- Torp, S., T. Riise, and B. Moen. "The impact of psychosocial work factors on musculoskeletal pain: A prospective study." *Journal of Occupational and Environmental Medicine* 43 (2001): 120–126.

- Tubiana, R., J. M. Thomine, and E. Mackin. *Examination of the hand and wrist*. London: Martin Dunitz, 1998.
- Tuttle, W. W., and B. A. Schottelius. *Textbook of physiology*. 16th ed. St. Louis, Mo.: C. V. Mosby, 1969.
- Ulin, S. S., and T. J. Armstrong. "A strategy for evaluating occupational risk factors of musculoskeletal disorders." *Journal of Occupational Rehabilitation* 2, no. 1 (1992): 35–50.
- U.S. Department of Health and Human Services. *Carpal tunnel syndrome: Selected references*. Washington, D.C.: U.S. Government Printing Office, 1989.
- U.S. Department of Health and Human Services. *Cumulative trauma disorders in the workplace: Bibliography*. DHHS (NIOSH) Publication No. 95-119. Washington, D.C.: NIOSH/DHHS, 1995.
- U.S. Department of Health and Human Services. *Device use safety: Incorporating human factors in risk managements guidance for industry and FDA premarket and postmarket*, rev. ed. Washington, D.C.: Center for Devices and Radiological Health, 1999.
- U.S. Department of Health and Human Services. *Elements of ergonomics programs: A primer based on workplace evaluations of musculoskeletal disorders*. DHHS (NIOSH) Publication No. 97-117. Washington, D.C.: NIOSH/DHHS, 1997.
- U.S. Department of Health and Human Services. *Musculoskeletal disorders and workplace factors: A critical review of epidemiologic evidence for work-related musculoskeletal disorders of the neck, upper extremity, and low back*. DHHS (NIOSH) Publication No. 97-141. Washington, D.C.: NIOSH/DHHS, 1997.
- U.S. Department of Labor. *Safety training requirements in OSHA standards and training guidelines*. OSHA Publication 2254. Washington, D.C.: DOL/OSHA, 1998.
- U.S. General Accounting Office/Health, Education, and Human Services. *Worker protection: Private sector ergonomics programs yield positive results*. GAO/HEHS Report 97-163. Washington, D.C.: GAO/HEHS, 1997.
- University of California Ergonomics Program. *Estimating muscle load using surface EMG amplitude*. Proceedings of the Marconi Research Conference, December 11–18, 1998, Marshall, California.
- Van Dieen, J. H., and V. Hermans. "Effects of dynamic office chairs on trunk kinematics, trunk extensor EMG and spinal shrinkage." *Ergonomics* 44, no. 7 (2001): 739–750.
- Vayrynen, S., H. Kirvesoja, H., and E. Kangas. "Multi-criteria ergonomic evaluation: A weighted objectives model for participative product design." *Occupational Ergonomics* 1 (1999): 125–134.
- Vince, M. A. "The intermittency of control movements and the psychological refractory period." *British Journal of Psychology* 38 (1948): 149–157.
- Vos, H. W. "Physical workload in different body postures, while working near to, or below ground level." *Ergonomics* 16, no. 6 (1973): 817–828.
- Washington State Department of Labor and Industries. *Cumulative trauma disorders in claims initiation follow-up*. SHARP Report No. 16-5-1992. Olympia: Washington State Department of Labor and Industries, Safety and Health Assessment and Research for Prevention (SHARP) Program, 1992.
- Wassell, J. T., L. I. Gardner, D. P. Landsittel, and J. J. Johnston. "A prospective study of back belts for prevention of back pain and injury." *Journal of the American Medical Association* 284, no. 21 (2000): 2727–2732.
- Wassermann, D. E. *The ergonomics of occupational hand-arm and whole-body vibration*. (NIOSH Course 596). Cincinnati, Ohio: D. E. Wasserman & Associates, 1993.
- . *Human aspects of occupational vibration*. Amsterdam: Elsevier, 1987.

- Waters, T. R., S. L. Baron, L. A. Piacitelli, V. P. Anderson, and T. Skov. "Evaluation of the revised NIOSH lifting equation: A cross-sectional epidemiologic study." *Spine* 24, no. 4 (1999): 386–395.
- Waters, T. R., and V. Putz-Anderson. *Applications manual for the revised NIOSH lighting equation*. Washington, D.C.: DHHS, 1994.
- Waters, T. R., V. Putz-Anderson, A. Garg, and L. Fine. "Rapid communication: Revised NIOSH equation for the design and evaluation of manual lifting tasks." *Ergonomics*, 36, no. 7 (1993).
- Weavers, S., and L. Haight. *Sports medicine and athletic training: Patient education manual*. Gaithersburg, Md.: Aspen Publishers, 1998.
- Wells, R., A. Moore, J. Potvin, and R. Norman. "Assessment of risk factors for development of work-related musculoskeletal disorders (RSI)." *Applied Ergonomics* 25, no. 3 (1994): 157–164.
- Wely, P. *Design and disease*. Philips Medical Service, 1970.
- Westfall-Lake, P., and G. N. McBride. *Shiftwork safety and performance: A manual for managers and trainers*. London: Lewis Publishers, 1998.
- Whiting, W. C., and R. F. Zernicke. *Biomechanics of musculoskeletal injury*. Champaign, Ill.: Human Kinetics, 1998.
- Wickens, C., and J. Hollands. *Engineering psychology and human performance*, 3rd ed. Upper Saddle River, N.J.: Prentice Hall, 2000.
- Wiktorin, C., L. Karlqvist, and J. Winkel. "Validity of self-reported exposures to work postures and manual materials handling." *Scandinavian Journal of Work, Environment and Health* 19, no. 3 (1993): 208–214.
- Williams, A. G., M. P. Rayson, and D. A. Jones. "Effects of basic training on material handling ability and physical fitness of British army recruits." *Ergonomics* 42, no. 8 (1999): 1114–1124.
- Williams, D., M. Feuerstein, D. Durbin, and J. Pezzullo. "Health care and indemnity costs across the natural history of disability in occupational low back pain." *Spine* 23 (1998): 2329–2336.
- Wilson, D. L. Proceedings of the Human Factors and Ergonomics Society 42nd Annual Meeting, 1998.
- Wilson, J. R., and E. N. Corlett. *Evaluation of human work: A practical ergonomics methodology*. London: Taylor & Francis, 1991.
- Wolinsky, I., D. Burr, and C. Milgrom. *Musculoskeletal fatigue and stress fractures*. London: CRC Press, 2001.
- Wood, D. D., D. L. Fisher, and R. O. Andres. "Minimizing fatigue during repetitive jobs: Optimal work-rest schedules." *Human Factors* 39, no. 1 (1997): 83–101.
- Woodson, W. E., B. Tillman, and P. Tillman. *Human factors design handbook*, 2nd ed. New York: McGraw-Hill, 1992.
- Work Loss Data Institute. *Disability benchmarks by major diagnostic category*. Corpus Christi, Tex.: Work Loss Data Institute, 2002.
- Young, L. C. "A study of tremor in normal subjects." *Journal of Experimental Psychology* 16 (1933): 644–656.
- Young, V. L., M. K. Seaton, and C. A. Feely. "Detecting cumulative trauma disorders in workers performing repetitive tasks." *American Journal of Industrial Medicine* 27 (1995): 419–431.
- Zhang, L. "Identifying factors of comfort and discomfort." *Human Factors* 38, no. 30 (1996): 377–389.
- Zirnheld, S., D. Aldridge, and J. Lago, J. *Documentation of OSHA ergonomics survey (final report)*. Bethesda, Md.: Washington Consulting Group, 1994.

## Additional References and Consensus Standards

AAMIHE	Human Factors Engineering Guidelines and Preferred Practices for the Design of Medical Devices (Second Edition)
ANSIR15.05-3	Industrial Robots and Robot Systems: Reliability Acceptance Testing; Guidelines
ANSI/AIAAG-035	Human Performance Measurements
ANSI/AIAAR-013	Recommended Practice for Software Reliability
ANSI/ASAS3.18	Evaluation of Human Exposure to Whole-Body Vibration, Guide for (ASA 38) (R 1993)
ANSI/ASHRAE55	Thermal Environmental Conditions for Human Occupancy
ANSI/ESDS5.1	REVISED - Human Body Model (HBM) Electrostatic Discharge Sensitivity Testing
ANSI/HFES100	Human Factors Engineering of Visual Display Terminal Workstations
ANSI/IEEE1023	Guide for the Application of Human Factors Engineering to Systems, Equipment, and Facilities of Nuclear Power Generating Stations
ANSI/SAEARP4032	Human Engineering Considerations in the Application of Color to Electronic Aircraft Displays
ANSI/SAEARP4107	Aerospace Glossary for Human Factors Engineers
ANSI/SAEJ833	Human Physical Dimensions: Recommended Practice, May 1989
ARINC628ITEM12.0	Reliability
ASAS3.18	Evaluation of Human Exposure to Whole Body Vibration: Guide for (ASA 38) (R 1993)
ASAS3.34	Guide for the Measurement and Evaluation of Human Exposure to Vibration Transmitted to the Hand (ASA 67)
ASAE456	Test and Reliability Guidelines (R 1991)
ASHRAE55	Thermal Environmental Conditions for Human Occupancy
SAEARP4107	Aerospace Glossary for Human Factors Engineers
SAEARP4153	Human Interface Criteria for Collision
SAEARP4155	Human Interface Design Methodology
SAEJ1460	Human Mechanical Response Characteristics: Information Report, March 1985
SAEJ833	Human Physical Dimensions, Recommended
SAEJ885	Human Tolerance to Impact Conditions as Related to Motor Vehicle Design: Information Report July 1986



## About the Author

---



**DEBORAH S. KEARNEY** is the president of Job Smart System, Inc., which specializes in risk management to improve productivity, safety, and quality to meet global standards. Job Smart System ([www.jobsmartsystem.com](http://www.jobsmartsystem.com)) supports safety professionals with a quantifiable approach to ergonomics. Creating environments with safe process engineering controls requires a systematic job safety analysis of job demands and the adaptive and assertive devices specific to industries, schools, health care facilities, and individuals.

Dr. Kearney is a member of the Human Factors and Ergonomics Society, the American Society of Safety Engineers, the American Psychological Association, and the International Facilities Management Association. She is a Registered Safety Manager (RSM) and an internationally recognized expert on ergonomics, human factors engineering, workstation design, and disability accommodation. She is the award-winning author of *Reasonable Accommodations: Job Descriptions in the Age of ADA, OSHA, and Workers' Comp*; *The ADA in Practice*; and *The New ADA: Compliance and Costs*. Dr. Kearney received her master's and doctoral degrees in psychology from the University of Massachusetts, Amherst.

